

microBlox™ Isolated I/O Modules with Bluetooth® Wireless Technology

Re-configuration Using the Acromag Agility™ Configuration Tool via Bluetooth Wireless Technology.

The Acromag Agility™ Configuration Tool is a mobile application that allows easy setup, calibration, and reconfiguration of microBlox™ I/O modules and alarm carriers. It supports reconfiguration of various Acromag devices via Bluetooth or a USB-OTG connection from a smartphone or tablet, depending on the device.

Bluetooth wireless technology enabled microBlox™ modules (“-B” suffix models) allow their input and output ranges to be wirelessly reconfigured and calibrated using a smart phone or tablet and the Agility mobile app (smart devices with Android 4.3 or higher or iOS 5.0 or later are supported). You can download this application free of charge from the Google Play™ Store at play.google.com (Android™), or the Apple® App Store® (Apple iOS/Cisco™).

Agility allows you to set and calibrate input and output ranges of microBlox™ modules (-B models only). Some models will include other configurable features that can be configured via this app. Additionally, you can poll, display, and trend input readings of microBlox™ modules. You can also perform quick and easy field diagnostics and troubleshooting, as well as review wiring diagrams for connected models. This summary will walk you through the setup and configuration of the uB31-B Voltage Input microBlox model. Other models are setup similarly.

Before You Begin:

This app can only be used to configure microBlox models with Bluetooth wireless technology which include a “-B” model suffix on their label.

Modules are plugged into 4, 8, or 16-channel back-panels, or single and dual channel alarm carriers. However, in order to use Bluetooth wireless technology to configure the module, you must set the back-panel channel DIP switch labeled BLE to ON at the channel (this enables radio-advertising by the module and allows it to Link to your smartphone or tablet). Note that it is good practice to return the channel BLE switch to OFF after you complete your reconfiguration. If you have many Bluetooth wireless technology models plugged into a back-panel, best results will be obtained by systematically setting the switch labeled BLE to ON for the channel, making your adjustments, then returning the switch OFF, and moving to the next module channel.

The channel switch labeled BLE is located just behind the field terminals of the channel (DIP switch 2) as shown at right and is enabled by using the tip of a pen or pencil, or toothpick to push the toggle left to the ON position.

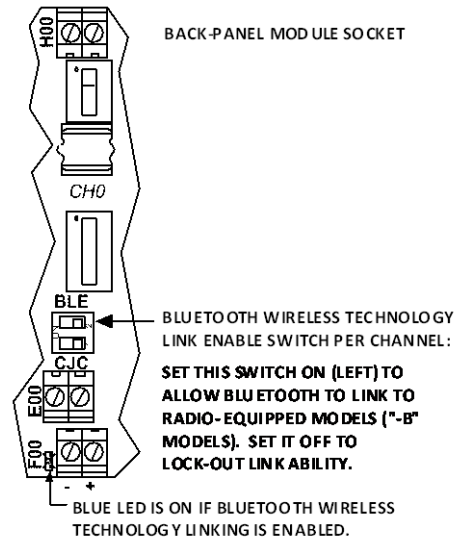

Pointer (Accessing Wiring Diagrams):

If you are viewing these screens on your smart device in the horizontal position, then a side-menu of wiring diagrams for connected devices is available. This right-hand menu is truncated if you are holding your smart device vertically.

Getting Started

Install your Bluetooth wireless technology enabled module into a back-panel channel socket and set that channel’s switch labeled BLE to ON now (see figure above to locate switch). With power applied, a blue LED next to the channel’s field terminals will be ON to indicate it is enabled for linking via Bluetooth wireless technology.

Be sure to also set the channel CJC switch ON or OFF according to the uB input module model (output models don’t care):

IMPORTANT - Back-Panel channel CJC switch settings required Per microBlox input module installed.	CJC Switch	uB30/40	uB31/41	uB32/42	uB34/35	uB37/47
	DONT CARE		√	√		
	SET ON	√				√
	SET OFF				√	

microBlox™ Isolated I/O Modules with Bluetooth® Wireless Technology



Now with your smart phone or tablet, select the Acromag Agility™ software application by tapping its icon (it looks like the icon shown at left).

Note: This same Acromag logo icon is located at the top left hand corner of most application screens and also serves as a Home button, which when tapped will return you to the Home page of the program from subsequent pages.

After the Agility software boots, you will be presented with a screen similar to the one at top left of the next page. If you tap the right-arrow on the Selected Device line you will get a Device List of in-range devices available for Bluetooth wireless technology connection (see second figure at left).

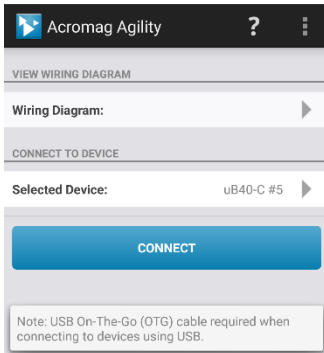

Your Bluetooth wireless technology enabled model is listed in the Device list (second figure at left) if you have properly enabled its channel switch labeled BLE to ON. Modules are discerned on this list by their Tag Name. The default tag name from the factory is the model and serial number of the module, but you can change these to your own unique tag names after making a connection.

At the top of the Device List, note the refresh/recycle icon on the right. This retries scanning. Tap this icon to rescan for available Bluetooth wireless technology connections as you add/remove modules. You may have to tap this a few times to get most available modules listed.

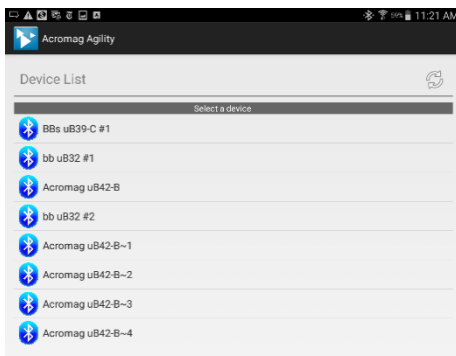

With up to 16 channels advertising at once, it can be difficult to get all 16 listed here at one time. You can try tapping the refresh icon to scan for more modules. If you still can't get all the available modules listed, you may have to systematically enable and disable channels as you configure them, in order to get access to all channels of a fully populated back-panel. Sometimes simply toggling the channel DIP switch labeled BLE OFF and ON for the absent channel will trigger its appearance on your Device List.

To Connect, simply tap to highlight and make your list selection, then tap the **[CONNECT]** bar to link to the selection (you can only link to one device at a time).

If the module you selected has password protection enabled, you will get the screen at lower left. Simply type in the required password and tap [Submit] or you will be denied reconfiguration access (**the factory-set initial default password is "password"**). Always record your password (your password is case-sensitive). If you never set a password, try using "password", or if have forgotten your password, a method for re-gaining access is outlined in the Settings section near the end of this manual.

Password Required

Please enter the device's password:

Type password here

Cancel
Submit

microBlox™ Isolated I/O Modules with Bluetooth® Wireless Technology

CONFIGURATION TAB

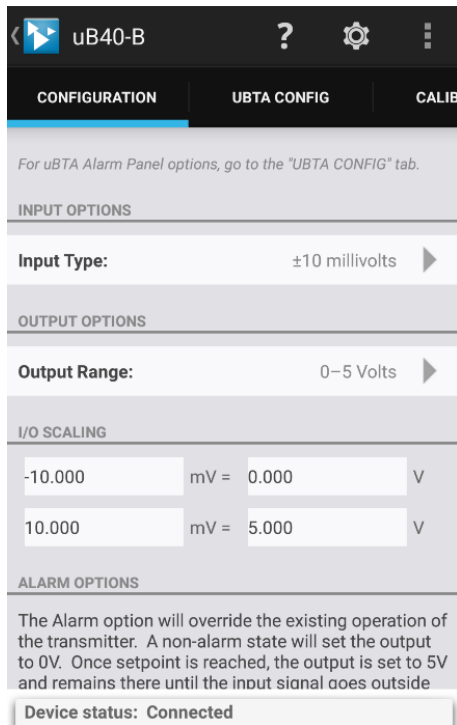

Most application pages cannot be accessed until you make a connection. But if for some reason you cannot connect to a module, the Help icon (?) of the action bar can be used to run communication diagnostics on your smart device, as well as provide other information for troubleshooting the connection.

After tapping **[CONNECT]** to connect to a device, the Configuration tab is displayed and a screen similar to that shown at left will appear (the uB31 is shown for example).

This is the key configuration screen for the connected module. Here you select the native Input Type/Range and Output Range, then use I/O Scaling to scale the input and output ranges you selected to your particular application range. You can optionally assign a tag name to the channel, or even choose to turn the transmitter channel into an alarm by specifying a Setpoint and Deadband for its optional alarm capability (input models only). Optionally, you can flip the alarm state from range full-scale to range zero via the Failsafe (Reverse Acting) OFF/ON switch. Note that alarm functionality over-rides channel transmitter operation and is separately enabled via the Enable Alarm OFF/ON switch.

Input Options – Input Type: Most input modules have 16-bit ADC inputs that support more than one input range. Select the smallest available range that contains the range you wish to setup for your specific application.

Output Options – Output Range: Most modules have DAC outputs that support more than one output range. Select the smallest available output range that contains the range you wish to setup for your specific application.

I/O Scaling - This is where you define your own input/output range for the Transmitter: For I/O Scaling, you can only enter values inside the selected nominal range boundaries and using the same units as the I/O ranges selected. It is recommended that for rated performance, you refer to the module specification sheet and the resolution specification for the input and output stages. You should only scale to input/output ranges greater than or equal to 4096x your lsb value (i.e. 12-bit minimum resolution). For example, the uB31 ±1V range has an lsb weight of 2V/27395 (resolution is 1/27395). Thus, your recommended minimum input span should be greater than or equal to $4096 * 2V / 27395 = 0.299V$. Failure to respect minimum resolution recommendations can degrade performance and magnify error. While you are not prevented from rescaling I/O ranges to lower resolutions, you should be cognizant of the tradeoff of increased error and noise as your effective resolution is reduced below 12-bits or 1 part in 4096.

Tag Name: You can enter up to 16 alphanumeric characters in the optional Tag Name field which allows you to discern this channel when scanning for devices to connect to by giving it a unique name. You will find this feature useful when you have many modules of the same type on a back-panel enabled for linking.

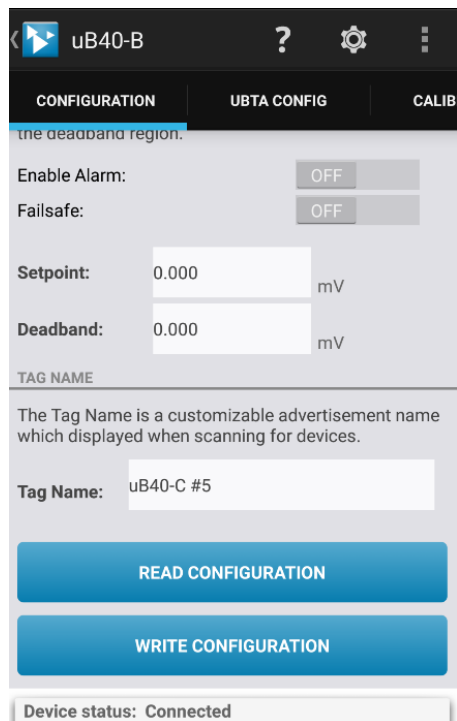

microBlox™ Isolated I/O Modules with Bluetooth® Wireless Technology

Alarm Option - About the Built-In High-Alarm Function:

If you specify a setpoint and/or deadband, and set Enable Alarm to ON, the built-in alarm feature will over-ride the transmitter function at the channel. When acting as an Alarm, the module output will go to full-scale (5V) when the input signal exceeds your setpoint, and will remain at full-scale if the input signal stays within the deadband region of your setpoint (high alarm only). For input signals below the high setpoint and outside of the deadband region, the host output signal will be set to zero or 0V. If you additionally set Failsafe (Reverse Acting) to ON, then the host output will go to 0V in alarm, and be set to 5V outside of alarm and deadband. Refer to figures below to understand how deadband is applied.

The built-in alarm function should not be confused with module operation using optional alarm carriers, which include dual alarm relays that can be individually configured as high or low alarms or window alarms. Refer to the alarm carrier manuals for more detail on alarm operation when mounted on alarm carriers.

Optional Alarm Carrier: The optional alarm carrier normally requires input modules to scale their input range to 0-5V for use on alarm carriers and this will also drive 0-20mA at the alarm carrier's current output. If your application requires a 4-20mA current output instead, you may use the I/O Scaling function of the Agility mobile app to scale your module input range to 1-5V output instead of 0-5V, which will produce 4-20mA from the alarm carrier (note the tandem voltage output of the alarm carrier also becomes 1-5V, not 0-5V). The Agility App will scale this for you if you select 4-20mA as your output range in the uBTA Alarm tab.

Read Configuration: If you tap [READ CONFIGURATION], the module's current I/O configuration will be read back for reference.

Write Configuration: If you tap [WRITE CONFIGURATION], the configured values you have selected or entered on this page will be written to the module. It is recommended you make all your selections first, then write your configuration one-time to configure the module. It's also a good idea to subsequently click [READ CONFIGURATION] to verify that your values were indeed written to the module.

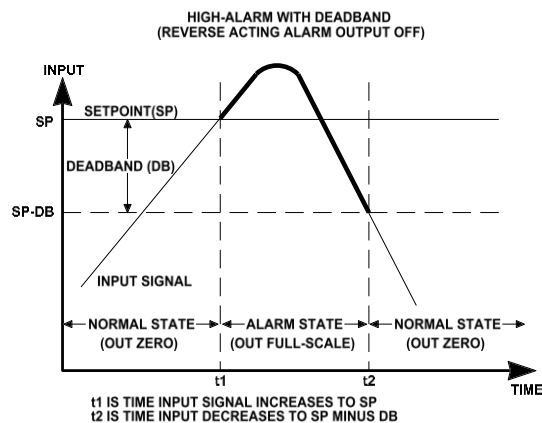

Note about Alarms: The optional high alarm capability that is built-into the module applies to all uB field input modules and its 5V alarm output is only limited to 5mA of available drive current. As such, it may be necessary to connect to an interposing relay in order to directly control external devices. Refer to the last page of this guide for one example of how to connect to one channel of an Acromag XTO-MRNO-6 relay module. Optionally, you could choose to mount an input module onto an alarm carrier, which has two alarm relays per channel and supports up to 5A of current without having to use an interposing relay.

microBlox™ Isolated I/O Modules with Bluetooth® Wireless Technology

uBTA CONFIG TAB

For more advanced alarm capability than the simple high alarm analog output of the uB module itself, you may optionally plug a Bluetooth wireless technology module into an optional uBTA alarm carrier. The alarm carrier provides two fully independent and isolated alarm outputs for a module, allowing you to setup two high, low, or Window alarms with separate dead band controls.

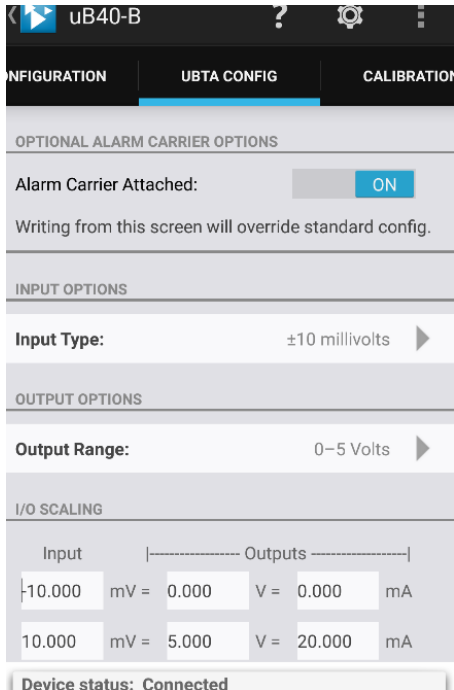

Select the Agility uBTA Config tab to display a screen similar that shown at left. To configure the connected module for use on an alarm carrier, drag the “Alarm carrier Attached” switch right to ON as shown at left to setup its carrier alarm capability.

Note that use of the carrier requires the module’s input to be scaled to 0-5V or 1-5V at its output as shown at left (this configuration will over-ride the standard Input/Output configuration if Alarm Carrier Attached is set to ON as shown at left. You may configure each relay as a high, low, or window alarm output, with separate dead band and failsafe control as shown in the second screen at left. Setting an alarm to Failsafe ON is equivalent to a reverse acting alarm in that fail-safe relay action refers to matching the alarm state of the contacts to the power-off state. Relay LED’s of the carriers indicate the relay energized condition.

Note that a window alarm may be configured for the relay and would trip for any input level outside the window defined by the high and low values specified (see Alarm Operation on page 16).

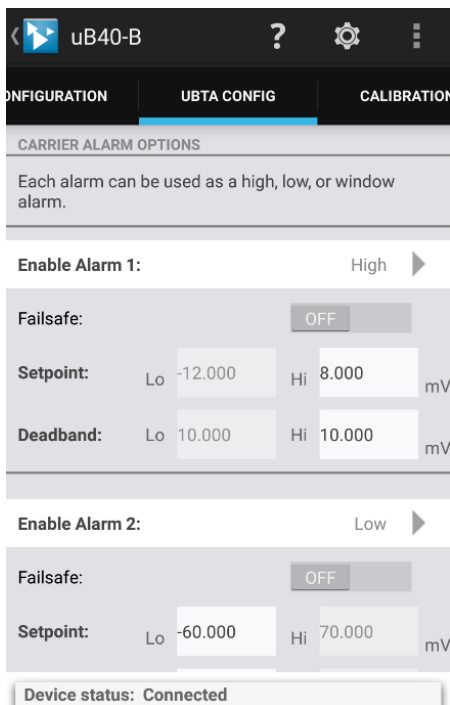

microBlox™ Isolated I/O Modules with Bluetooth® Wireless Technology

CALIBRATION TAB

IMPORTANT: This unit has already had its input & output channels factory calibrated with high precision. If you have configured your unit and note excessive error, you can tap the Calibration tab to display the Calibration page shown. If you attempt to recalibrate the input or output channel, you could degrade its performance if you do it improperly, use lower grade equipment, or fail to set or measure precise signal levels. Consider your decision to calibrate carefully.

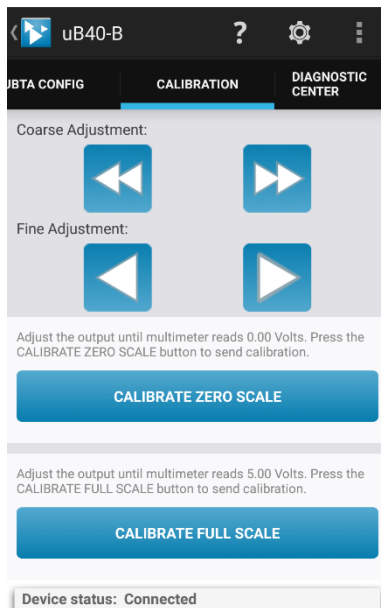

If you tap the Calibration tab, you will see a screen similar that shown at left. This screen allows you to separately calibrate the Input (A/D) and Output (D/A) for the Input and Output ranges that you have selected and written to the module from the previous Configuration page.

Input: The Calibration - Input portion of the application marks the input zero and full-scale digital counts of the module's A/D converter that correspond to the precise \pm full-scale range endpoint levels wired to the input.

CAUTION-Input Calibration: Always wire the precise endpoint values of your selected input range. Driving input levels outside the selected nominal input range is not acceptable for calibration of zero or full-scale. Since input levels cannot be separately validated during calibration, driving incorrect signal levels to the unit will produce an undesired output response.

IMPORTANT: The Input range being calibrated is indicated at the top. To calibrate another range, return to the Configuration page, then select/write a different range to the module. Some ranges automatically calibrate other ranges. For example, the \pm 5V output range calibrates the 0-5V range, and if you happen to choose the 0-5V output range, the instructions will direct you to calibrate the \pm 5V range.

Follow the screen prompts and connect a precise input zero signal to the input. Then tap **[CALIBRATE ZERO SCALE]** to mark the internal A/D digital count associated with the range zero input measurement.

Follow the screen prompts and connect a precise input full-scale signal to the input. Then tap **[CALIBRATE FULL SCALE]** to mark the internal A/D digital count associated with the range full-scale input measurement. The internal microcontroller will use the two calibration points to linearly translate its input measurement between the range endpoints.

Output: Connect a precision multi-meter to the output of this transmitter. For best results, load the output similar to your application. Use the output adjustment slider and/or coarse adjustment button to adjust the output signal indicated on your meter to precisely output zero. Use the Fine Adjustment buttons to step the output one lsb at a time to get the output signal to the precise zero output level, then click **[CALIBRATE ZERO SCALE]** to record the zero endpoint DAC count corresponding to the zero signal level.

After setting the output zero, use the output adjustment slider and/or coarse adjustment button to adjust the output signal indicated on your meter to precisely output full-scale. Use the Fine Adjustment buttons to step the output one lsb at a time to get the output signal to the precise full-scale output level, then click **[CALIBRATE FULL SCALE]** to record the range endpoint DAC count corresponding the full-scale signal level. The internal microcontroller will use the two calibration points to linearly translate its DAC count to the analog signal level for the output range.

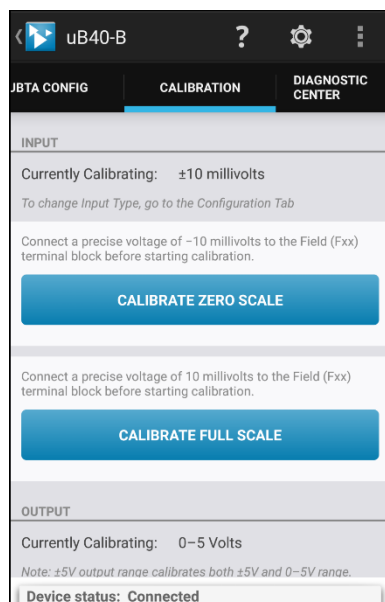

microBlox™ Isolated I/O Modules with *Bluetooth*® Wireless Technology

DIAGNOSTIC CENTER TAB

This area of the Application is useful for testing the operation of your module by allowing you to poll the module wirelessly, and display its reading digitally or graphically (trend). You can also log this data and share it with other devices.

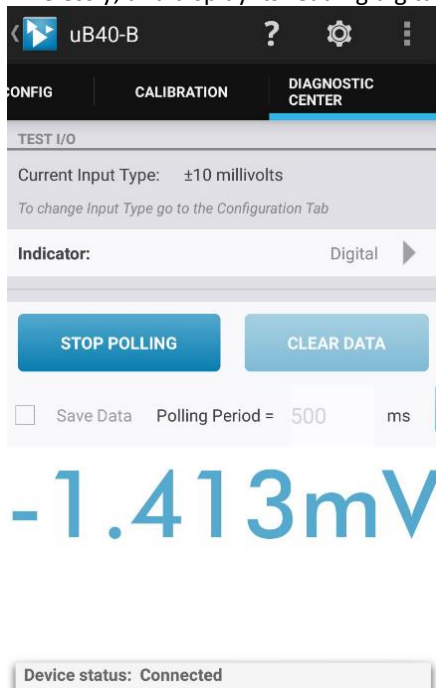

Tap the Diagnostic Center tab to access the Polling page shown at left.

Test I/O (To Verify Input Operation)

The currently configured input type/range will be indicated at the top.

To select a different input range, return to the Configuration page (either click the Configuration tab, or simply slide your page to the right until the Configuration page is shown).

If you tap the **Indicator** field, you can tap again to select Digital or Graph display of the periodic reading. After selecting Digital or Graph, click on **Start Polling**.

If you wish to save the polling data, click on “Save Data” and enter the polling period from 500mS to 60000mS (60 sec).

NOTE: Saved Data is logged continuously to your mobile device at the polling rate you choose, up to the limits of your device’s memory. Each poll consumes an average of 10 Bytes. Your consumption would be $\sim 10 * (\text{duration} / \text{Poll Period})$. A one hour trend at a 500ms interval, would use $\sim 10 * 3600 \text{ sec} / 0.5 \text{ sec} = \sim 70\text{KB}$ memory.

If you do not choose Save Data, up to 5000 points can be trended (if polling is not stopped before 5000 samples, oldest data will be dropped as new data is acquired).

START POLLING – tap to begin polling the input. The current input measurement will be displayed in engineering units (Digital) or as a Graph. The display will be updated according to your polling period.

If you checked “Save Data”, your data is logged every polling period to a Comma Separated Value (CSV) Excel file in the root/Acromag folder of your mobile device. The app will automatically create this directory in your device if it does not already exist. This folder is accessed through a file explorer, either if the device has one built in or through a PC connection using windows explorer.

SAVE & CLEAR – tap to stop data logging at any time. Multiple files can be saved to this folder. Each file is stored independently and named with the tag name of the device as well as a timestamp from when the polling was started.

To share the most recent saved data, tap the “share icon” to send a CSV data log file to another device. For example, you could choose to email the data log file. Older files are accessed with the file explorer.

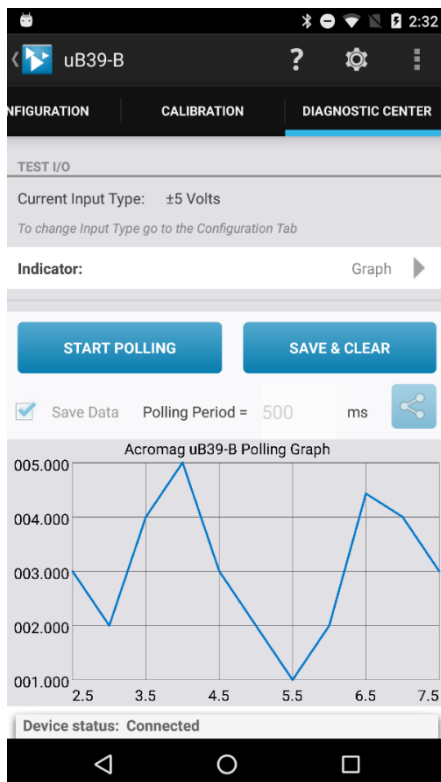

microBlox™ Isolated I/O Modules with *Bluetooth*® Wireless Technology



HELP Icon for the Troubleshooting Page

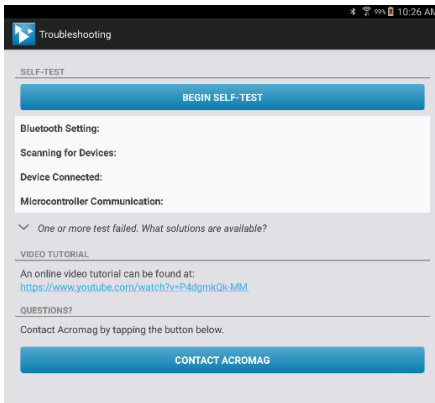

This area of the application invokes a Self-Test feature that can be used to determine if your smart phone or tablet has its Bluetooth wireless technology enabled, whether any modules can be found (via rescan), whether a device is connected, and whether the microcontroller of the connected module is operational. You simply tap **[BEGIN SELF-TEST]** to perform the diagnostic exchange and review the results returned. If one or more tests indicate Failed, you can also tap the down arrow message below the self-test report to access additional information regarding failed tests.

Optionally, you can review an online video tutorial on working with the microBlox by tapping the Video Tutorial URL line.

Or, if you wish to contact Acromag for assistance, you can tap **[CONTACT ACROMAG]** to obtain the phone and email information shown at left for talking to Acromag directly (the same information is also obtained via the menu action bar icon and “Contact Acromag” selection).

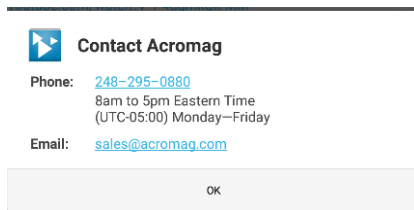

Settings Icon for Utility Page to Reboot, Restore Factory Settings & Calibration, or Set Password Access

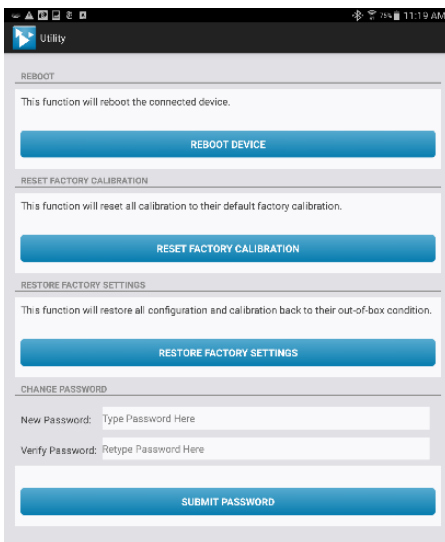

Tap the Settings icon in the action bar at the top right of your screen to access the Utility Page shown at left.

You can tap **[REBOOT DEVICE]** on this page to reset/restart the connected module, perhaps if it ever appears to freeze, or is operating erratically. This is akin to a power-on reset.

You can tap **[RESET FACTORY CALIBRATION]** to get out of trouble if you ever miscalibrate a transmitter (this only affects module calibration).

You can tap **[RESTORE FACTORY SETTINGS]** to get out of trouble if you ever misconfigure or miscalibrate a transmitter (this affects both module calibration and your configuration).

You can use and Verify the Password fields to optionally set password protection for Bluetooth wireless technology reconfiguration by first typing a password and then tapping **[SUBMIT PASSWORD]** to one (up to 16 alphanumeric characters). If you set a Password, the second box shown at left will prompt you if you try to connect to a password protected device (**the initial factory-set default password is simply “password”**).

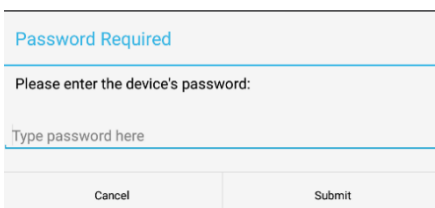

WARNING: If you forget your password, you will be locked out from accessing the module via this software. So be very careful to type and record your password before tapping **[SUBMIT PASSWORD]**. Your password is case-sensitive. If you happen to forget your password, you can always gain access via a 60 second temporary password of “password” by first toggling the back-panel Bluetooth low energy technology switch twice when prompted for the password by the screen at left (i.e. ON-OFF-ON-OFF-ON).

microBlox™ Isolated I/O Modules with Bluetooth® Wireless Technology



Menu Icon For “About” & “Contact Acromag” Information



Acromag Agility

Version: 3.0

Copyright: © 2016 - 2017 Acromag Inc.

Product includes:
Graphview © 2016 Jonas Gehring
Licensed under the GNU Lesser General Public
License (LGPL)
<http://www.gnu.org/licenses/lgpl.html>

OK



Contact Acromag

Phone: [248-295-0880](tel:248-295-0880)
8am to 5pm Eastern Time
(UTC-05:00) Monday-Friday

Email: sales@acromag.com

OK

You can download these reference documents and more at www.acromag.com.

If you tap the right-most Menu icon of the action bar at the top right of your screen, you will get a selection menu for “About” information on this software application, and “Contact Acromag” for Acromag contact information, both shown at left.

Refer to the specific module reference document listed below or the microBlox™ family reference document for additional operation details and information on other available microBlox™ modules and accessories.

REFERENCE	DESCRIPTION
8501-037	uB31 & uB41 Voltage Input User Reference
8501-038	microBlox™ Module Family Reference
8501-039	uB39 Current Output User Reference
8501-040	uB30 & uB40 mV Input User Reference
8501-041	uB32 DC Current Input User Reference
8501-042	uB42 DC Current Input w/2-Wire Excitation User Reference
8501-043	uB34 2/3-Wire & uB35 4-Wire RTD Input User's Reference
8501-044	<i>Acromag Agility Config Tool for microBlox (This Manual)</i>
8501-045	uB45 Frequency Input User Reference
8501-047	uB37 & uB47 TC Input User Reference
8501-048	uBDC1 Power Supply User Reference
8501-049	uB49 Voltage Output User Reference
8501-050	uB04/uB08/uB16 Back-Panel User Reference
8501-074	uBDN4/uBDN8/uBDN16 DIN Rail Conversion Kit Instructions
8501-079	uBTA-H-1x Single Transmitter/Alarm Carrier for microBlox™
8501-080	uBTA-P-1x Single Transmitter/Alarm Carrier for microBlox™
8501-081	uBTA-P-2x Dual Transmitter/Alarm Carrier for microBlox™
8501-109	uBSP-P-1 uB Module Panel Splitter to Dual Isolated I/V Outputs

All microBlox™ input models with the Bluetooth wireless technology option (“-B” suffix models) can optionally be configured to operate as an alarm instead of transmitter, but its voltage output drive capability is limited to 5V/5mA. However, you could use an interposing relay to control larger loads, or mount the uB module onto one of our uBTA transmitter/alarm carriers. The diagram below shows how to use a microBlox™ input model and one channel of an interposing relay like the Acromag XTA-MRNO-6 to give the alarm greater drive capability for controlling larger loads.

microBlox™ Isolated I/O Modules with Bluetooth® Wireless Technology

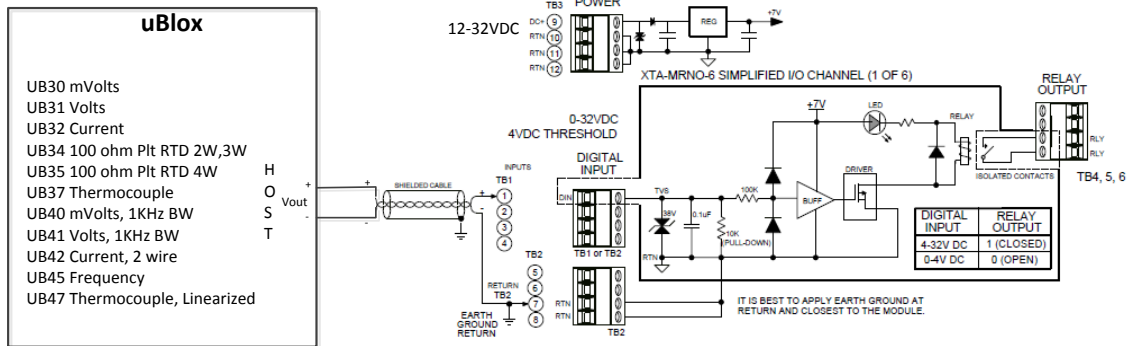

uBlox HOST output connection to XTA-MRNO-6 for single input, single output alarm relay configuration.

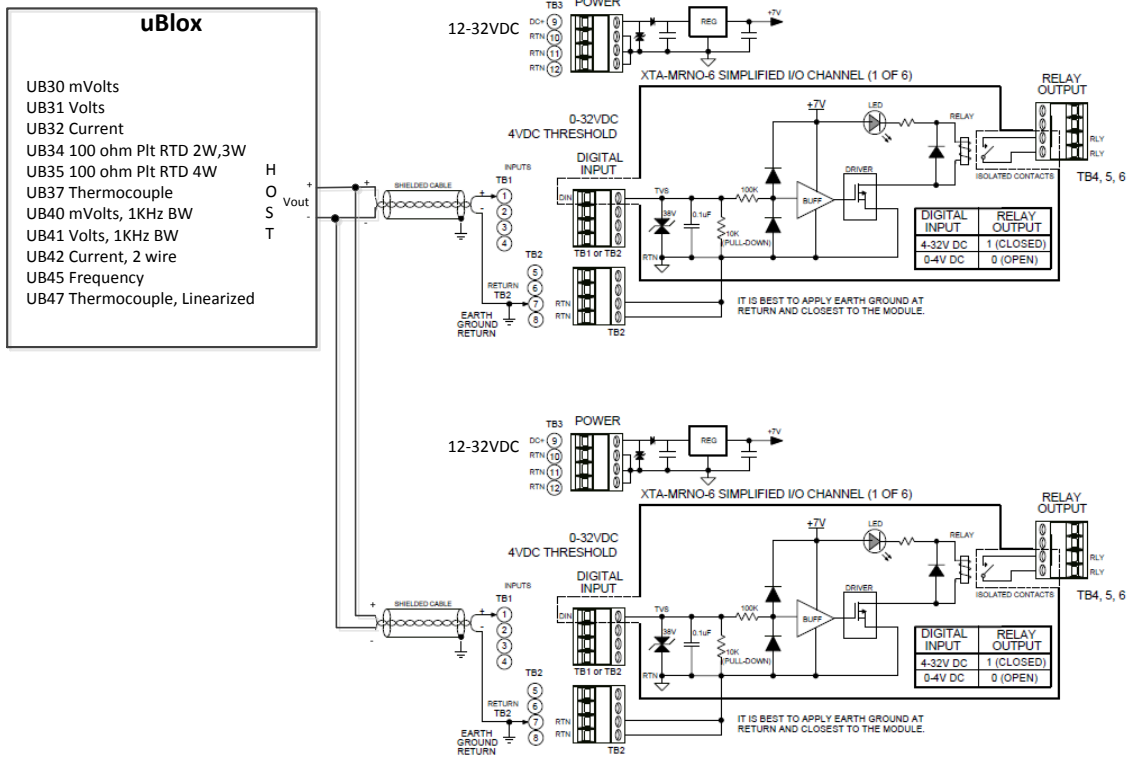

uBlox HOST output connection to XTA-MRNO-6 for single input, multiple output alarm relay configuration.

The Bluetooth® word mark and logos are registered trademarks owned by the Bluetooth SIG, Inc. and any use of such marks by Acromag is under license, other trademarks are the property of their respective owners. Copyright © Acromag, Inc. 2016. Data subject to change without notice.

Revision History for this document:

Release Date	Revision	EGR/DOC	Description of Revision
05 JUN 2016	A	BC/MJO	Initial Release.
25 JUL 2017	B	BC/MJO	Add 4-20mA Enhancement.
31 OCT 2017	C	BC/MJO	Added CJC switch settings, misc. edits, formatting changes.
15 JUN 2020	D	BC/ARP	Added additional Default password information.