

**USB Programmable, DIN Rail Mount,
Dual Isolated Transmitter for RTD/Resistance Inputs
and Passive 2-Wire 4-20mA Transmitter Outputs**

Model DT235-0600, 2/3/4-Wire RTD/Resistance Input

USER'S MANUAL



**ACROMAG INCORPORATED
30765 South Wixom Road
Wixom, MI 48393-2417 U.S.A.**

**Tel: (248) 295-0880
email: sales@acromag.com**

Copyright 2018, Acromag, Inc., Printed in the USA.
Data and specifications are subject to change without notice.

8501134E

Table of Contents

GETTING STARTED	4
DESCRIPTION.....	4
Key Features.....	4
Application	5
Mechanical Dimensions	5
DIN Rail Mounting & Removal.....	6
ELECTRICAL CONNECTIONS	7
Input Connections.....	7
Output/Power Connections	9
Earth Ground Connections	12
USB Connection	12
CONFIGURATION SOFTWARE.....	14
Quick Overview – Android Reconfiguration	14
Quick Overview – Windows	20
TECHNICAL REFERENCE.....	22
OPERATION STEP-BY-STEP	22
Connections.....	22
Configuration.....	23
Calibration (Optional)	26
RTD Resistance versus Temperature	28
BLOCK DIAGRAM	29
How It Works.....	29
TROUBLESHOOTING.....	30
Diagnostics Table.....	30
Service & Repair Assistance	32

ACCESSORIES 33

- Software Interface Package.....33
- USB Isolator33
- USB A-B Cable.....33
- USB A-mini B Cable33

ACCESSORIES 34

- USB OTG Cable34
- End Stops.....34

SPECIFICATIONS 35

- Model Numbers.....35
- Inputs (Each).....35
- Outputs (Each).....37
- USB Interface.....39
- Enclosure & Physical39
- Environmental40
- Reliability Prediction.....40
- Agency Approvals41
- Configuration Controls.....41

REVISION HISTORY 42

All trademarks are the property of their respective owners.

IMPORTANT SAFETY CONSIDERATIONS

You must consider the possible negative effects of power, wiring, component, sensor, or software failure in the design of any type of control or monitoring system. This is very important where property loss or human life is involved. It is important that you perform satisfactory overall system design and it is agreed between you and Acromag, that this is your responsibility.

The information of this manual may change without notice. Acromag makes no warranty of any kind with regard to this material, including, but not limited to, the implied warranties of merchantability and fitness for a particular purpose. Further, Acromag assumes no responsibility for any errors that may appear in this manual and makes no commitment to update, or keep current, the information contained in this manual. No part of this manual may be copied or reproduced in any form without the prior written consent of Acromag, Inc.

This manual is for our dual channel 2-wire/loop-powered DT235 transmitter that convert RTD or resistance input signals to dual isolated passive current output loops. If your application requires dual output 4-wire transmitters (w/ separate isolated DC power input) that drives active sourcing voltage/current outputs, please refer to similar SP300 series models.

GETTING STARTED

DESCRIPTION

Symbols on equipment:



Means "Refer to User's Manual (this manual) for additional information"

Key Features

The DT235-0600 provides two isolated ANSI/ISA Type II transmitters for RTD or resistance input signals, and separately modulates two isolated 2-wire current loops proportional to the respective inputs. Dual transmitters may operate as single or dual channel devices, or as a channel 1 signal splitter. Units are setup, calibrated, and scaled using configuration software and a USB connection to Windows-based PC's (Windows 7 and later versions only), or using a USB-OTG cable to Android smartphones or tablets using the Agility mobile app. Units provide an adjustable & scalable input and output, variable input filtering, and I/O isolation.

- **Dual Channels in a thin 17.5mm wide enclosure for high-density mounting.**
- **Digitally configured and calibrated w/ Windows software via USB, or a wired USB-OTG connection to Android smartphones or tablets.**
- **This dual transmitter also functions as a single transmitter, or signal splitter.**
- **RTD transmitter output is linearized with respect to temperature (°C or °F).**
- **Resistance transmitter output is linearized with respect to resistance (Ω).**
- **Connects to two-wire, three-wire, or four-wire sensors.**
- **Pt100, Pt200, Pt500, Pt1000, Copper, and Nickel type RTDs supported.**
- **25Ω, 450Ω, 2250Ω, and 4500Ω resistive ranges also supported.**
- **Three wire sensor wiring compensates for lead-wire resistance.**
- **Four-wire sensor wiring eliminates error associated with lead-wire resistance.**
- **Supports up-scale or down-scale lead-break/burnout detection.**
- **Supports Celsius, Fahrenheit, and Kelvin temperature units.**
- **Each transmitter channel has high measurement accuracy & linearity w/24-bit input & 16-bit output conversion.**
- **Adjustable input ranges and adjustable output ranges. Transmitter inputs and outputs can be scaled independently and differently for each channel.**
- **Extra output connection supports optional sourced output wire termination.**
- **Variable input filter adjustment (none, low, medium, high).**
- **Channels can transmit to Normal or Reverse Acting outputs.**
- **Transmitters have very low loop burden with terminal voltage down to 7V.**
- **Each 2-wire loop powered transmitter has non-polarized output connections.**
- **You may program output clamp limits or select Namur compliant range/limits, helpful to discern over-range conditions from fault detection.**
- **Variable input filter adjustment (none, low, medium, high).**
- **Wide-range DC power input from 6-32V is bus/redundant power ready.**
- **Wide ambient temperature operation from -40°C to +80°C.**
- **Thoroughly tested and hardened for harsh environments.**
- **CE Approved.**
- **FCC Conformity Class B**
- **cULus Listed - Class I/Division 2 - Haz. Loc., ATEX, & IECEx.**

Application

For additional information on these devices and related topics, please visit our web site at www.acromag.com and download our whitepaper 8500-904, Introduction to Two-Wire Transmitters.

These dual channel transmitters are designed for high-density mounting on T-type DIN rails. Channel pairs may be mounted side-by-side on 17.5mm centers.

Models isolate two channels of RTD or resistance inputs and mate with grounded or non-grounded sensors. Each channel drives an isolated 4-20mA output current loop that is linearized to sensor temperature (RTD) or resistance (resistance input).

The transmitter output signals are dual, two-wire, 4-20mA current loops, allowing signal transmission over long distances with high noise immunity. Its inherent live-zero 4mA offset current offers built-in output fault detection, should an output wire break. An extra connection screw at each output allow it to be optionally wired for a “sourced” 4-20mA output configuration (see Optional Output Wiring).

Mechanical Dimensions

Units may be mounted to 35mm “T” type DIN rail (35mm, type EN50022), and side-by-side on 0.69-inch centers.

WARNING: IEC Safety Standards may require that this device be mounted within an approved metal enclosure or sub-system, particularly for applications with exposure to voltages greater than or equal to 75VDC or 50VAC.

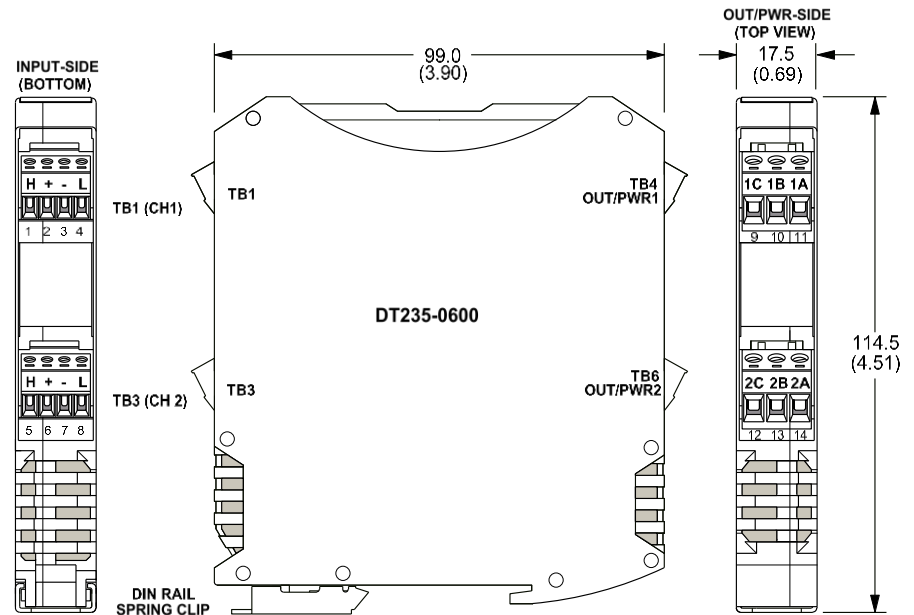

DIMENSIONS ARE IN MILLIMETERS (INCHES)

DIN Rail Mounting & Removal

NOTE: It is recommended that this unit be mounted upright on a DIN rail allowing free air flow intake from the bottom vent to flow through the unit and out the top vent. This will allow the unit to run cooler, operate better, and help to extend the life of the electronics.

Refer to the following figure for attaching and removing a unit from the DIN rail. A spring-loaded DIN clip is located on the input side bottom. The opposite rounded edge at the bottom of the output side allows you to tilt the unit upward to lift it from the rail while prying the spring clip back with a screwdriver. To attach the module to T-type DIN rail, angle the top of the unit towards the rail and place the top groove of the module over the upper lip of the DIN rail. Firmly push the unit downward towards the rail until it snaps into place. To remove it from the DIN rail, first separate the input terminal blocks from the bottom side of the module to create a clearance to the DIN mounting area. You can use a screwdriver to pry the pluggable terminals out of their sockets. Next, while holding the module in place from above, insert a screwdriver into the lower path of the bottom of the module to the DIN rail clip and use it as a lever to force the DIN rail spring clip down while pulling the bottom of the module outward until it disengages from the rail. Then simply lift it from the rail.

DT23x DUAL TRANSMITTER DIN RAIL MOUNTING AND REMOVAL

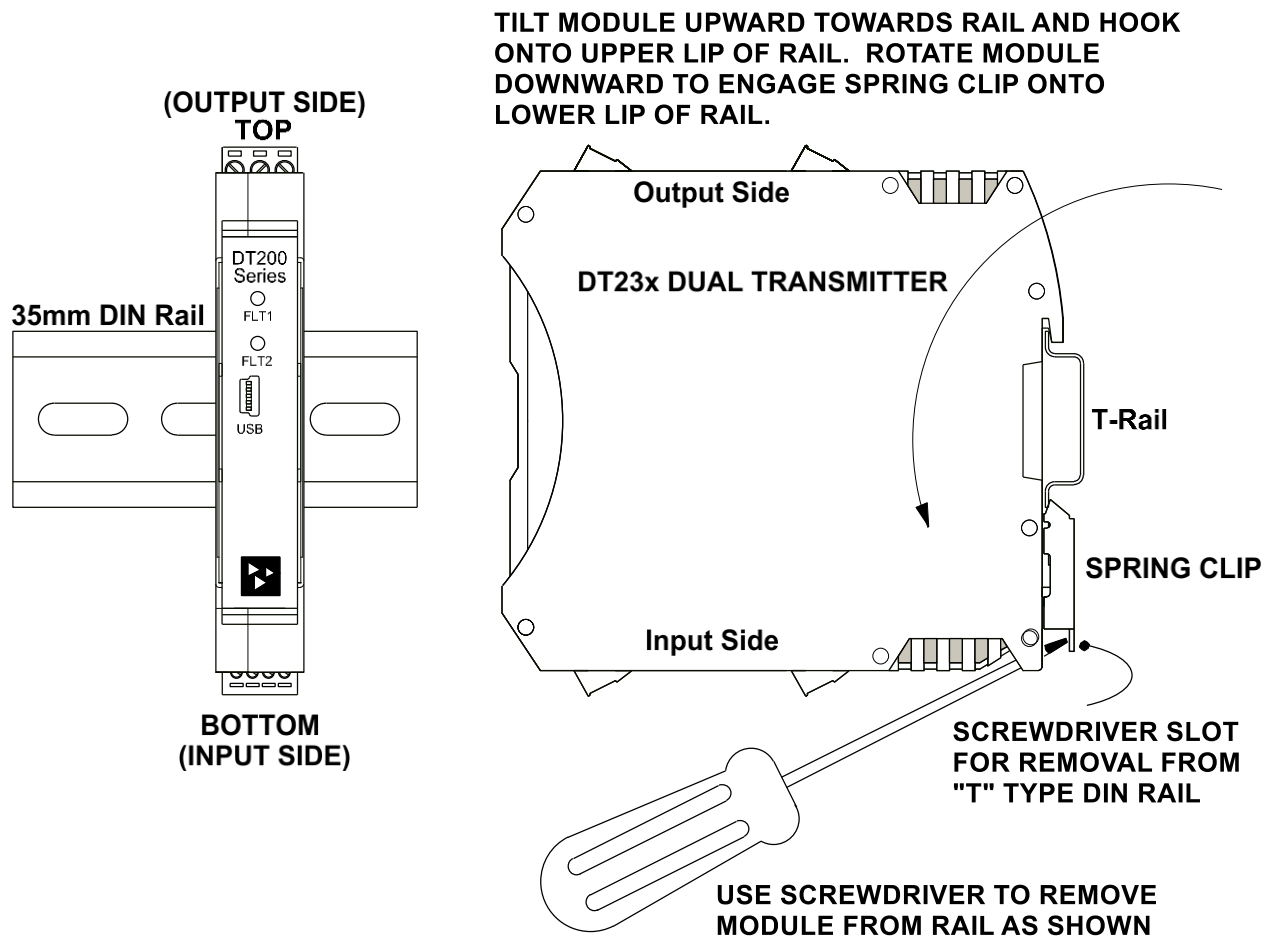

ELECTRICAL CONNECTIONS



WARNING – EXPLOSION HAZARD – Do not disconnect equipment unless power has been removed or the area is known to be non-hazardous.

WARNING – EXPLOSION HAZARD – Substitution of any components may impair suitability for Class I, Division 2.

WARNING – EXPLOSION HAZARD – The area must be known to be non-hazardous before servicing/replacing the unit and before installing.

Output terminals can accommodate 14–28 AWG (2.08–0.081mm²) solid or stranded wire with a minimum temperature rating of 90°C (14-30 AWG for input wires). Input wiring may be shielded or unshielded type. Ideally, output wires should be twisted pair, or shielded twisted pair. Terminals are pluggable and can be removed from their sockets by prying outward from the top with a flat-head screwdriver blade. These models support isolated inputs at TB1 and TB3. Strip back wire insulation 0.25-inch on each lead and insert the wire ends into the cage clamp connector of the terminal block. Use a screwdriver to tighten the screw by turning it in a clockwise direction to secure the wire (0.5-0.6Nm torque). Use adequate wire insulation and follow proper wiring practices as common mode voltages can exist on signal wiring. As a rule, output wires are normally separated from input wiring for safety, as well as for low noise pickup.

Important – End Stops: For hazardous location installations (Class I, Division 2 or ATEX/IECEx Zone 2), it should utilize two end stops (like Acromag 1027-222) to help secure modules to the DIN rail (not shown).

Input Connections

Inputs are isolated. Sensor wires are wired directly to transmitter input terminals at the bottom of the module (the spring-loaded DIN clip side), as shown in the connection drawing at right. Observe proper polarity when making input connections.

MODEL DT235-0600 INPUT SENSOR WIRING

SEE FOLLOWING PAGE FOR DIFFERENT INPUT WIRING SCHEMES FOR RTD INPUT, CHANNEL READS EQUIVALENT TEMPERATURE IN DEGREES CELSIUS OR FAHRENHEIT AND OUTPUT IS LINEARIZED TO TEMPERATURE.

FOR RESISTANCE INPUT, CHANNEL READS RESISTANCE IN OHMS AND OUTPUT IS LINEARIZED TO RESISTANCE.

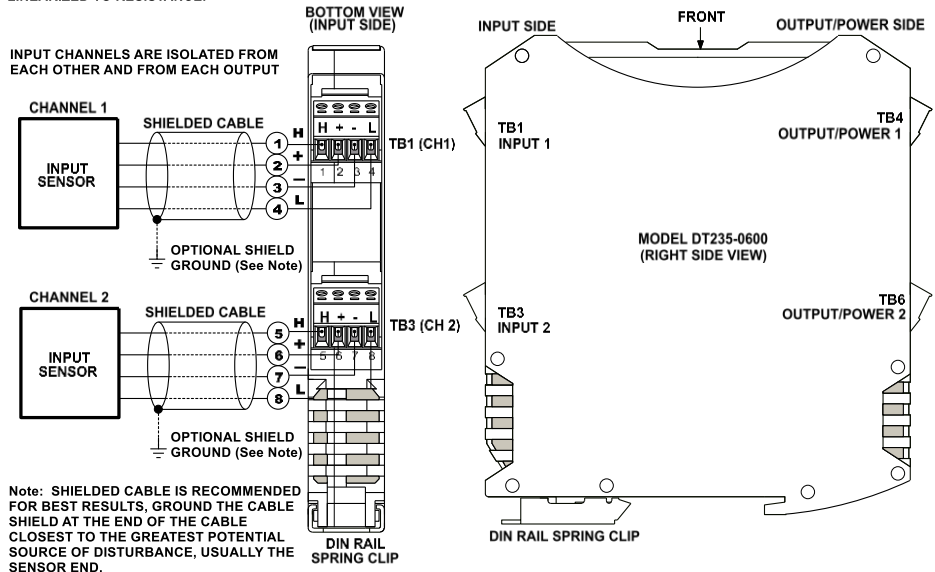

4-WIRE RTD INPUT SENSOR WIRING

NOTE: LEAD-WIRE RESISTANCE
LEAD-WIRE RESISTANCE HAS A NEGLIGIBLE EFFECT ON THE RTD MEASUREMENT WHEN USING A 4-WIRE CONFIGURATION.

CHANNEL READING IS IN EQUIVALENT RTD TEMPERATURE IN DEGREES CELSIUS OR FAHRENHEIT

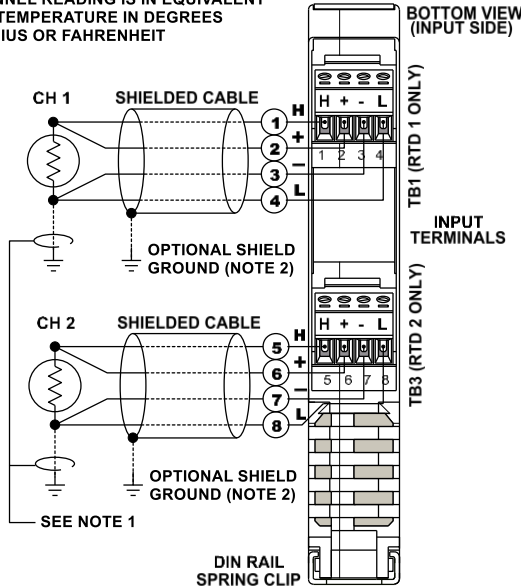

3-WIRE RTD INPUT SENSOR WIRING

NOTE: LEAD-WIRE RESISTANCE
LEAD-WIRE RESISTANCE HAS NEGLIGIBLE EFFECT ON THE RTD MEASUREMENT WHEN THE + AND L LEADS ARE MATCHED (OF EQUAL LENGTH & GAGE)

CHANNEL READING IS IN EQUIVALENT RTD TEMPERATURE IN DEGREES CELSIUS OR FAHRENHEIT

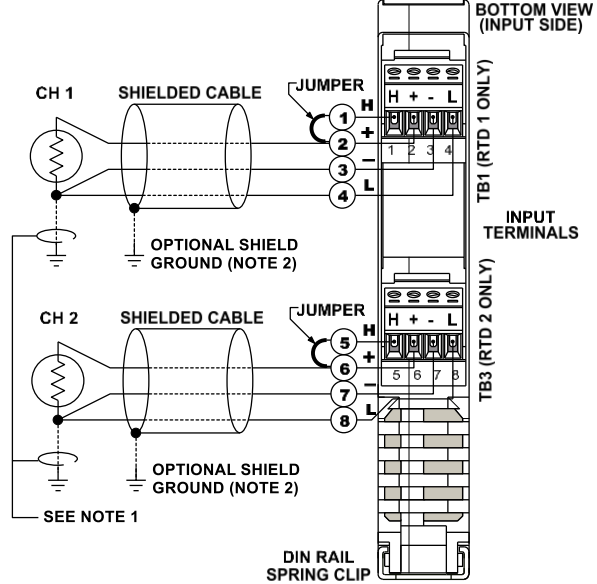

2-WIRE RTD INPUT SENSOR WIRING

NOTE: LEAD-WIRE RESISTANCE
LEAD-WIRE RESISTANCE OF THE + & - LEADS CAUSES A POSITIVE SHIFT IN RTD MEASUREMENT PROPORTIONAL TO THE EQUIVALENT TEMPERATURE OF THE SUM TOTAL OF THE INPUT (+) & INPUT (-) LEAD RESISTANCES.

CHANNEL READING IS IN EQUIVALENT RTD TEMPERATURE IN DEGREES CELSIUS OR FAHRENHEIT

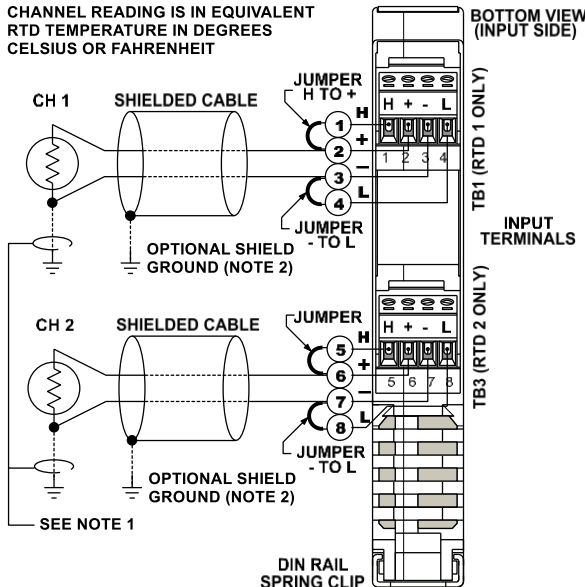

NOTE 1: SENSOR GROUND

THIS GROUND CONNECTION IS RECOMMENDED FOR BEST RESULTS. IF SENSORS ARE INHERENTLY CONNECTED TO GROUND, USE CAUTION AND AVOID MAKING ADDITIONAL GROUND CONNECTIONS WHICH COULD GENERATE GROUND LOOPS AND MEASUREMENT ERRORS. DO NOT GROUND THE INPUT SENSOR IF UNIT IS CONNECTED TO A GROUNDED PC WITHOUT AN USB ISOLATOR.

NOTE 2: OPTIONAL CABLE SHIELD GROUND

SHIELDED CABLE IS RECOMMENDED. FOR BEST RESULTS, GROUND THE CABLE SHIELD AT THE END OF THE CABLE CLOSEST TO THE GREATEST POTENTIAL SOURCE OF DISTURBANCE, USUALLY THE SENSOR END.

4-WIRE RESISTANCE DECADE BOX WIRING

CONNECT SAME AS FOR 4-WIRE RTD CONNECTION

NOTE: LEAD-WIRE RESISTANCE
LEAD-WIRE RESISTANCE HAS A NEGLIGIBLE EFFECT ON THE RTD MEASUREMENT WHEN USING A 4-WIRE CONFIGURATION.

CHANNEL READING IS LINEAR
RESISTANCE IN OHMS

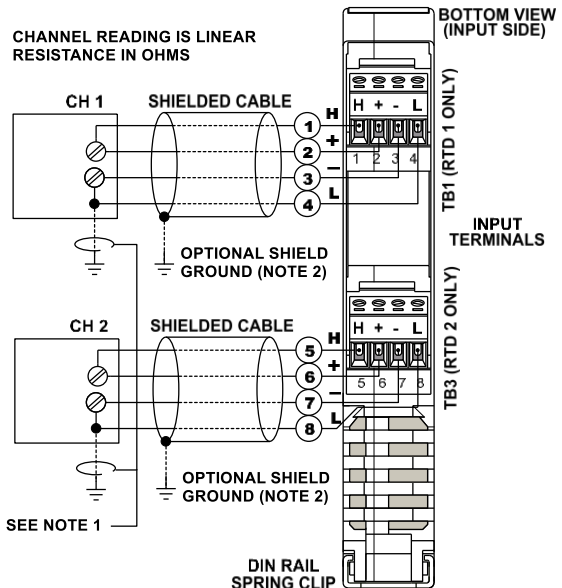

Input Connections...

- **Channel inputs are isolated from each other and from each output.** USB input is common to input channel 1.
- **Three-wire input connections will require one wired jumper to be placed between input (H) and input (+)** which routes sensor excitation current from the input (H) terminal to the input (+) lead of the sensor and passing through the sensor to produce a voltage drop measured differentially between the input (+) and input (-).
- **Two-wire input connections & resistance require two wired jumpers to be placed between input (+) and input (H), and between input (-) and input (L).** The second jumper routes the sensor excitation return current from input (-) to the A/D reference resistance at the input (L) terminal to accomplish ratio-metric conversion of the sensor signal. Ratio-metric conversion refers to measuring sensor resistance as a ratio of the reference resistance used to drive the A/D reference, rather than measuring it using an absolute reference voltage. By using the same excitation current to excite both the sensor and the A/D reference resistor at the same time, any changes in excitation current will be immediately reflected in the ADC reference, resulting in a more accurate and stable measurement.
- **Four-wire input connections use no wired jumpers and eliminate potential error associated with sensor lead-wire resistance,** as the sensor voltage is measured differentially using a different pair of leads (input + and -) than the pair that carries the sensor excitation current (input H and L), effectively removing any lead-wire IR drop from the sensor measurement by the A/D. A 3-wire input connection accomplishes the same thing, but only if the input wires match in diameter, length, and material (and therefore resistance).

Output/Power Connections

This dual channel transmitter has two isolated ANSI/ISA Type 2 outputs in which the channel's power and output signal share the same two leads, and each transmitter channel output has a "floating" connection with respect to earth ground. Connect a DC power supply and load in series in each of the two-wire output loops as shown in the drawings that follow.

- **Passive channel output connections are not polarized.** The output + and - designations are for reference only with current normally input to Output+ and returned via Output- (current sinking). Output 1 powers the input and microcontroller, while output 2 powers isolated input channel 2.
- **Loop supply voltages should be from 7-32V DC** with the minimum voltage level adjusted to over-range current in the loop load plus 7V MIN across the transmitter, plus any transmission line drop.
- **Variation in rated power voltage has negligible effect on transmitter accuracy** between the 7V min required by the transmitter and 32V maximum allowed.
- **Variation in load resistance has negligible effect on output accuracy** if the loop supply voltage level is set correctly for the load resistance.
- **Note the traditional placement of earth ground in the current loop.** Output Earth ground is normally applied at the loop power supply minus terminal, not the transmitter output. Each 2-wire transmitter output varies off this ground by the voltage drop in the load resistance and lead-wire of the loop.

MODEL DT235-0600 OUTPUTS/POWER WIRING
TRADITIONAL LOOP-POWERED "SINKING OUTPUT" CONNECTIONS

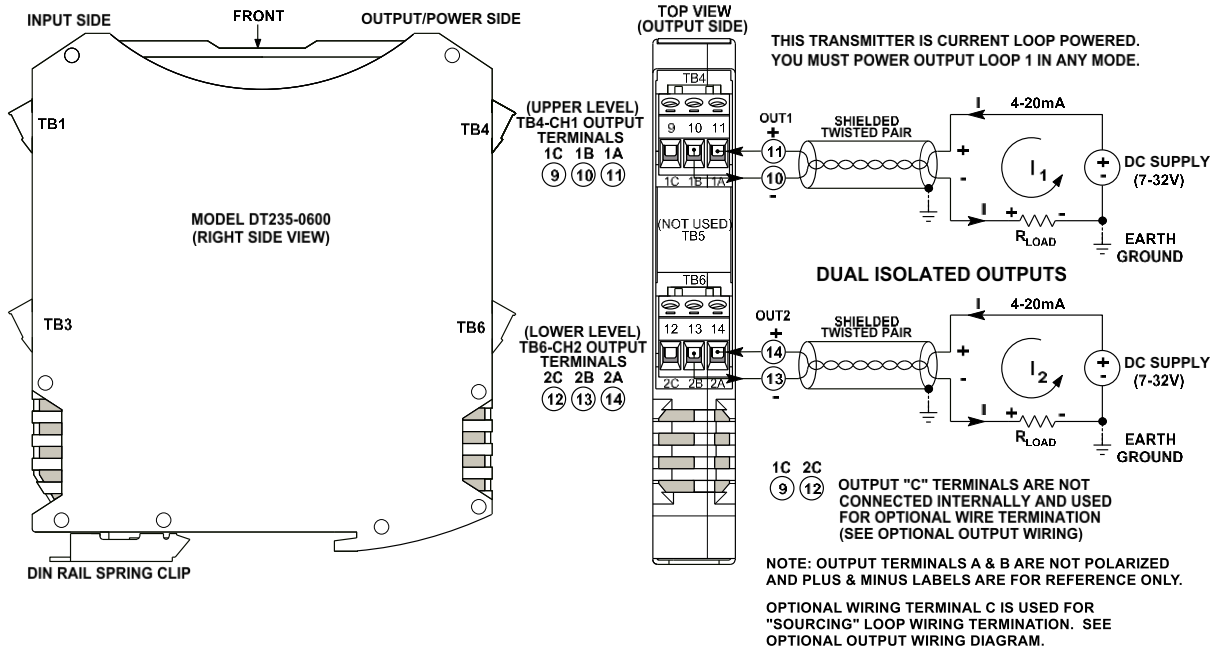

Output/Power Connections...

WARNING: For compliance to applicable safety and performance standards, the use of twisted pair output wiring is recommended. Failure to adhere to sound wiring and grounding practices as instructed may compromise safety, performance, and possibly damage the unit.

Traditional 2-wire loop-powered "sinking" output connections are shown above. Shielded twisted-pair wiring is often used at the outputs to connect the longest distance between the field transmitter and the remote receivers as shown. Each output of this transmitter is isolated and fluctuates relative to earth ground by the voltage drop in the output load and connection wire. This makes it flexible in the way it connects to various "Receiver" devices.

In most installations, the output loop power supply will be local to either the transmitter, or the remote receiver of the loop. Common receiver devices may include the input channel of a Programmable Logic Controller (PLC), a Distributed Control System (DCS), or a panel meter. Some receiver devices already provide excitation for the transmitter loop and these are referred to as "sourcing inputs". Other receivers that do not provide loop excitation are referred to as "sinking" inputs, and these will require that a separate power supply connect within the loop. These types of receivers are depicted in the figures on the next two pages.

TIP - Ripple & Noise: Place additional capacitance at the load to help reduce the 60Hz/120Hz ripple sometimes present in industrial applications. For large 60Hz ripple, connect an external 1uF or larger capacitor directly across the load to reduce excess ripple. Most modern systems will use high-speed acquisition at the load making them more sensitive to noise--high frequency noise may be significantly reduced in these applications by placing a 0.1uF or 0.01uF capacitor directly across the load, as close to the load as possible (this may also raise RF immunity).

TIP - Inductive Loads: If either two-wire current loop include a highly inductive load (such as an I/P current-to-pressure transducer), this may reduce output stability. In this case, place a 0.1uF capacitor directly across the inductive load(s) and this will typically cure the problem.

Output/Power Connections...

MODEL DT235-0600 OUTPUT WIRING "SINKING OUTPUT" CONNECTIONS WITH POWER LOCAL TO THE RECEIVER

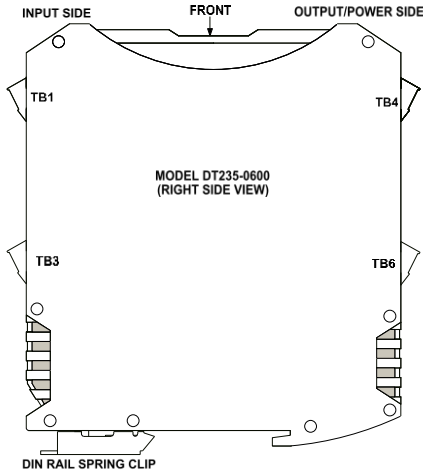

COMMON TWO-WIRE LOOP CONNECTION TO "SOURCING" AND "SINKING" INPUT RECEIVERS

Two-Wire Output Connections to the Input Card of a Distributed Control System or Programmable Logic Controller.

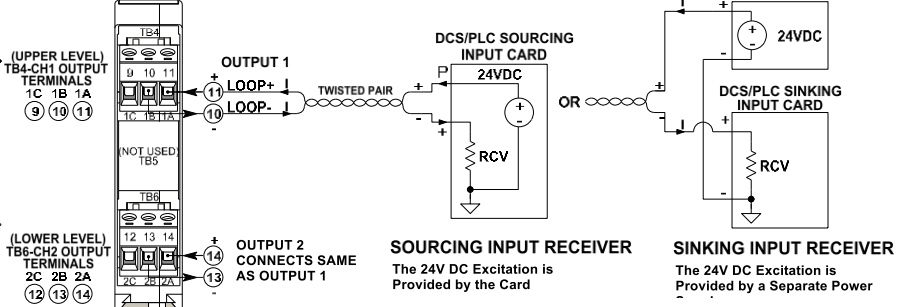

This model includes an extra termination screw at each output marked "C" which is intended to provide a convenient tie point for a "sourcing" wiring variation as shown below. The C terminals do not connect to the internal circuit but are used to simply join wired connections. Use of this terminal in your wiring scheme allows you to connect external power local to the transmitter and form a "sourcing" entity from this "sinking" output as shown below.

MODEL DT235-0600 OPTIONAL OUTPUT WIRING OPTIONAL "SOURCING OUTPUT" CONNECTIONS WITH POWER LOCAL TO TRANSMITTER

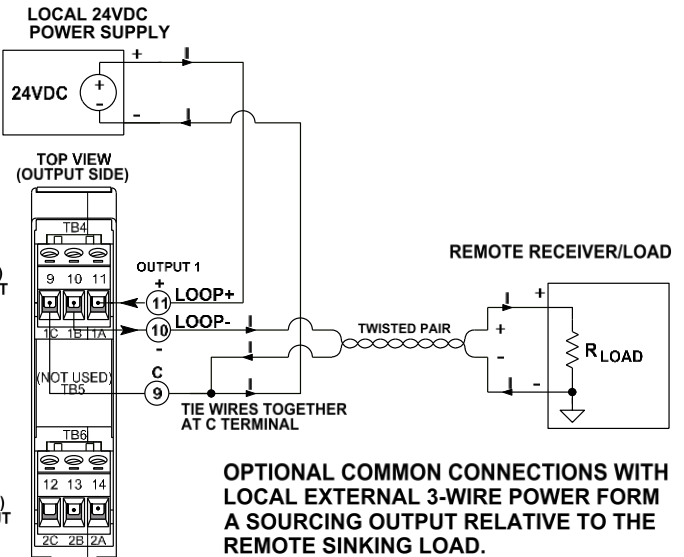
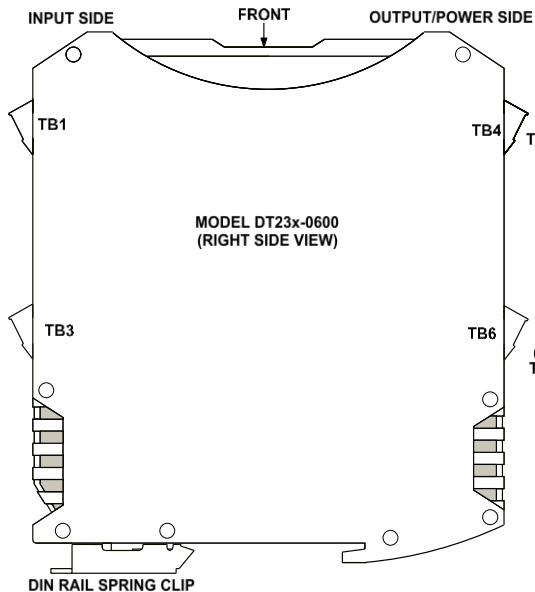

Earth Ground Connections

IMPORTANT: A USB isolator is recommended when configuring or calibrating a unit to avoid the ground loop that occurs if your input signal is also earth grounded (A PC commonly ties earth ground to its USB port signal and shield ground, which is held in common to the input circuit ground of this transmitter).

The unit housing is plastic and does not require an earth ground connection to itself. If the module is mounted in a metal housing, an earth ground wire connection to that metal housing's ground terminal (green screw) is usually required using suitable wire per applicable codes. As a rule of good practice, isolated circuits are normally earth grounded at one point. See the Electrical Connections Drawing for Output/Power connections and note the traditional position of earth ground for a two-wire output current loop. That is, earth ground is normally applied at the output loop power minus terminal and in common with the loop load or loop receiver minus. The Type II transmitter output terminals will have a "floating" connection relative to earth ground and their potential varies with the voltage drop in the load and connection wire. Circuits wired to isolated analog inputs should be earth grounded as reflected in their input connection diagram. Ground connections noted are recommended for best results and help protect the unit and its isolated circuitry by giving it a low impedance path to ground for shunting destructive transient energy away from sensitive module circuitry. Respect the traditional position of earth ground in a two-wire current loop and avoid inadvertent connections to earth ground at other points in the same loop, which would drive ground loops and negatively affect operation.

USB Connection

DT transmitters are setup, configured, & calibrated via configuration software that runs on a Windows-based PC connected via USB (Windows 7 or later required), or a USB connection to a compatible Android-based tablet or smartphone with our Agility mobile APP installed. Refer to the drawing below to connect your PC or laptop to the transmitter for reconfiguration and calibration using this software (the optional connection to an Android smartphone or tablet would typically not require the use of an isolator, because those devices are battery powered).

USB Connection...

DT SERIES DUAL USB TRANSMITTER CONNECTIONS

USED FOR CONFIGURATION AND CALIBRATION OF THE TRANSMITTER IN A SAFE OR ORDINARY LOCATION

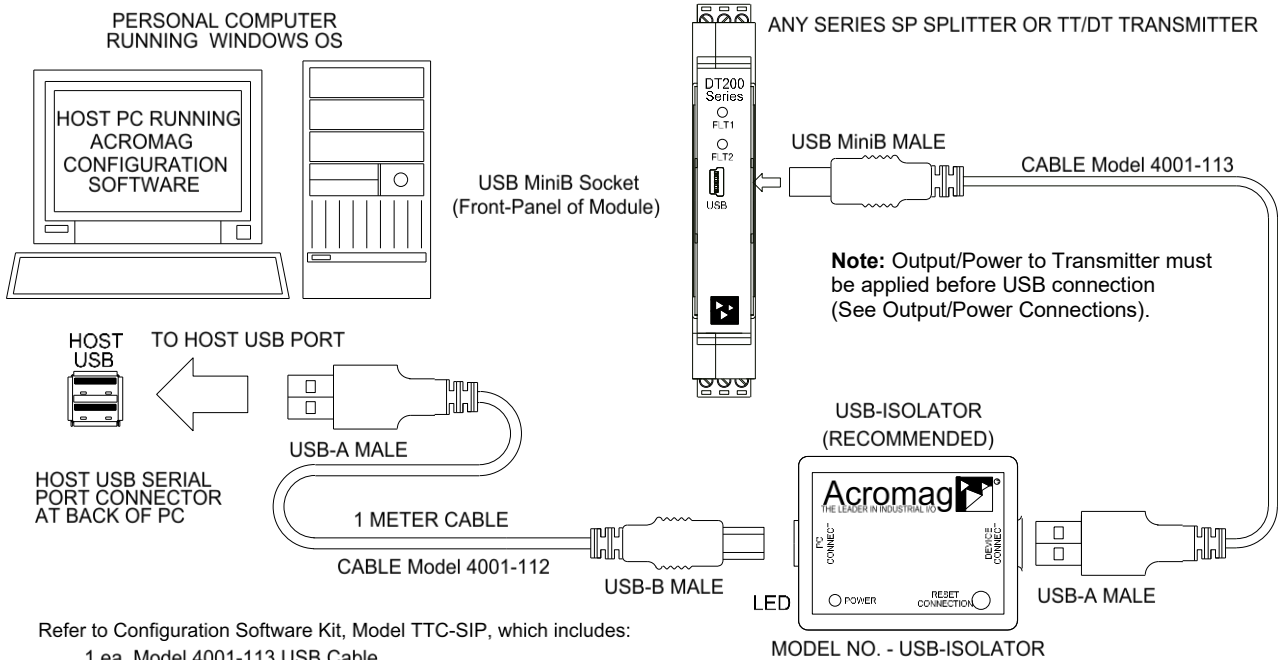

Refer to Configuration Software Kit, Model TTC-SIP, which includes:

- 1 ea, Model 4001-113 USB Cable
- 1 ea, Model 4001-112 USB Cable
- 1 ea, Model USB-ISOLATOR
- 1 ea, Configuration Software CDROM 5040-944

USB Connection...



WARNING: The intent of mating USB with this transmitter is so that it can be conveniently set up and calibrated in a safe area, then installed in the field which may be in a hazardous area. Do not attempt to connect a PC or laptop to this unit while installed in a hazardous area, as USB energy levels could ignite explosive gases or particles in the air.

- **USB Signal Isolation is Required (See IMPORTANT Below)** - You may use Acromag model USB-ISOLATOR to isolate your USB port, or you can optionally use another USB signal isolator that supports USB Full Speed operation (12Mbps).
- **Configuration Requires USB and Loop Power** - This transmitter draws power from both the current loop and from USB during set up.

IMPORTANT: USB logic signals to the unit are referenced to the potential of its internal signal common. This ground is held in common with the USB ground and shield ground. The potential of a transmitter’s current output pin (output minus) relative to earth ground varies with the load current and resistance (net IR drop). Without isolation, IR drop would drive a potential difference between the normally grounded current loop and grounded USB connection at the PC, causing a ground loop that would inhibit set up & calibration, or may even damage the transmitter. It is recommended you use an isolated USB connection. Alternatively, you could avoid using an isolator if a battery powered laptop was used to connect to the transmitter, and the laptop has no earth ground connection, either directly or via a connected peripheral.

CONFIGURATION SOFTWARE

Quick Overview – Android Reconfiguration

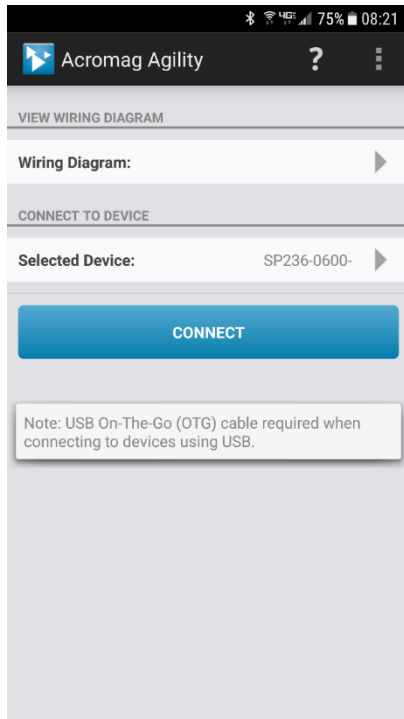

This transmitter can be configured & calibrated via the Acromag Agility™ Config Tool App. This software app can be downloaded free of charge from the Google Play store at play.google.com and is compatible with Android devices that use Ice Cream Sandwich (4.0) or later OS.

To connect to this transmitter, a USB OTG (On-The-Go) cable (Acromag 5028-565) and USB A to Mini-B cable (Acromag 4001-113) are also required. When you start the app, the initial Agility Connection screen at left will be presented and if you have also connected a module using a USB OTG cable, your module will be listed in the “Selected Device:” field of the Connection screen as shown.

The ability to select other devices only applies to Bluetooth devices which also utilize this app. Tap the **[CONNECT]** button to open communication with the device indicated to the right of “Selected Device” and move to the main portion of the app shown in the second screen at left. Note Android requires user permission to access external hardware--If the Device List displays “No Device Permission”, select the device and when prompted to give permission to access the USB device, and select **[OK]**.

If you wish to view a wiring diagram for your transmitter model, tap the arrow next to “Wiring Diagram”. You may swipe left or right to view more diagrams.

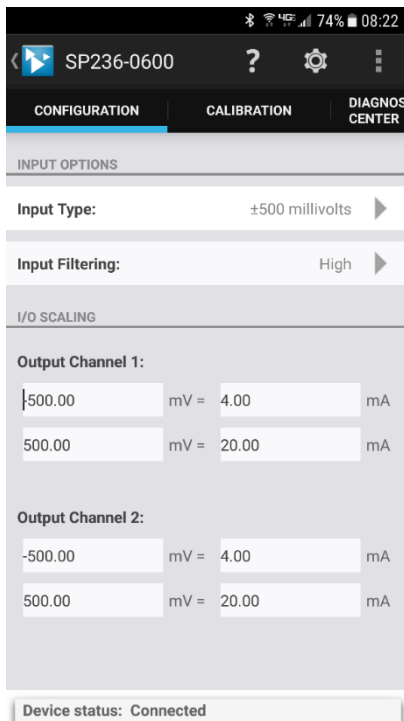

The main screen also has three icons across the top: an Acromag logo w/connected model indicated, a question mark, a gear icon, and three vertical dots. These icons access additional features of this software as follows:



This icon located in the top left-hand corner of most app screens serves as a Home button, which when tapped will return you to the Connection page of the app from subsequent pages.



Tapping the question mark will access a Self-Test utility useful for testing your device connection.



Tapping the Gear/Settings icon will access a Utility Page to do a device Reboot, Reset Factory Calibration, or restore factory Settings.



Tapping this icon will return “About” & “Contact Acromag” Information.

A short description of what each icon does follows:

Quick Overview – Android Reconfiguration...continued

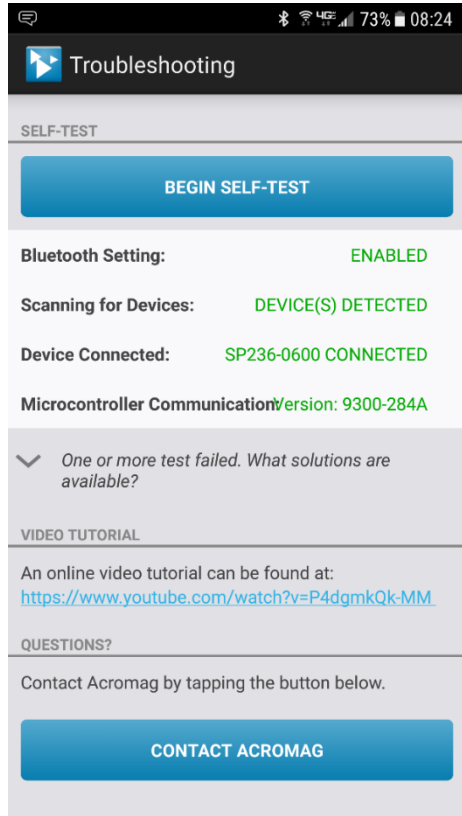

The HELP area of the application invokes a Self-Test feature that can be used to determine if your smart phone or tablet has its Bluetooth wireless technology enabled (useful for microBlox product applications), whether any modules can be detected by rescanning, whether a device is connected, and whether the microcontroller of the connected module is operational. You simply tap **[BEGIN SELF-TEST]** to perform the diagnostic exchange and review the results returned. If one or more tests indicate Failed, you can also tap the down arrow message below the self-test report to access additional information regarding failed tests. Optionally, you can review an online video tutorial on working with the unit by tapping the Video Tutorial URL line.

Or, if you wish to contact Acromag for assistance, you can tap the **[CONTACT ACROMAG]** bar to obtain the phone and email information window shown below for talking to Acromag directly (the same information is also obtained via the menu dotted action bar icon and “Contact Acromag” selection).

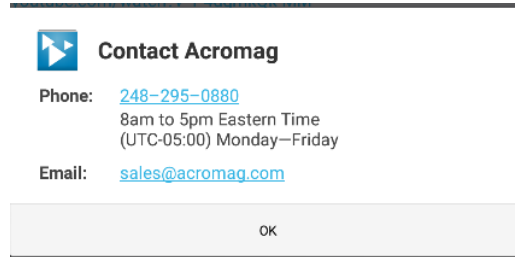

You may also refer to the Troubleshooting Table in this manual which lists common issues related to working with these transmitters and some recommended remedies.

Quick Overview – Android Reconfiguration...continued

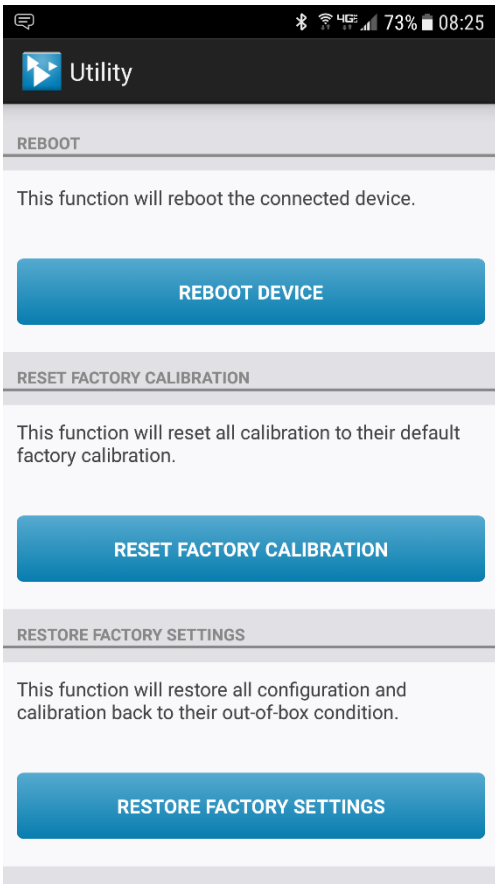

Tap the **[Gear]** icon in the Action bar to access the Utility Page shown at left. Utilize these features if you if you encounter erratic behavior with your transmitter and need to get out of trouble, perhaps if you ever inadvertently misconfigure or improperly calibrate a transmitter.

You can tap **[REBOOT DEVICE]** on this page to reset/restart the connected transmitter, perhaps if it ever appears to freeze, or exhibits erratic operation. This is akin to a power-on reset of the transmitter.

You can tap **[RESET FACTORY CALIBRATION]** to get out of trouble if you ever miscalibrate a transmitter (this only affects transmitter calibration).

You can tap **[RESTORE FACTORY SETTINGS]** to get out of trouble if you ever misconfigure or miscalibrate a transmitter (this affects both transmitter calibration and configuration). You can also use this feature to de-commission a transmitter.



Acromag Agility

Version: 3.0
Copyright: © 2016 - 2017 Acromag Inc.
 Product includes:
 Graphview © 2016 Jonas Gehring
 Licensed under the GNU Lesser General Public License (LGPL)
<http://www.gnu.org/licenses/lgpl.html>

OK



Contact Acromag

Phone: [248-295-0880](tel:248-295-0880)
 8am to 5pm Eastern Time
 (UTC-05:00) Monday–Friday
Email: sales@acromag.com

OK



If you tap the right-most dotted Menu icon of the action bar at the top right of your screen, you will get a selection menu for “About” information on this software application, and “Contact Acromag” for contact information, both shown at left

Below the icons of the top line are file three tabs: Configuration, Calibration, and Diagnostic Center, each of which are described in the following pages.

Quick Overview – Android Reconfiguration...continued

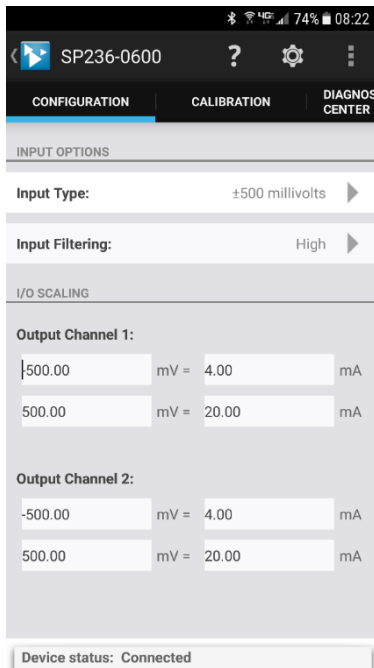

Input/Output Configuration

The I/O Configuration screen is shown at left and is used to Configure your transmitter Input and Output. You can set your input type/range, input digital filtering level, rescale each output, and even scale the input differently for each output via this screen.

Note that if your unit is connected when you select this tab, the app automatically reads your transmitter’s current I/O and scaling information and displays it.

Likewise, changing any option on this page sends the changes to the transmitter immediately.

Note that the Device Status is indicated at the bottom of all pages and will report if changes were sent successfully (Connected).

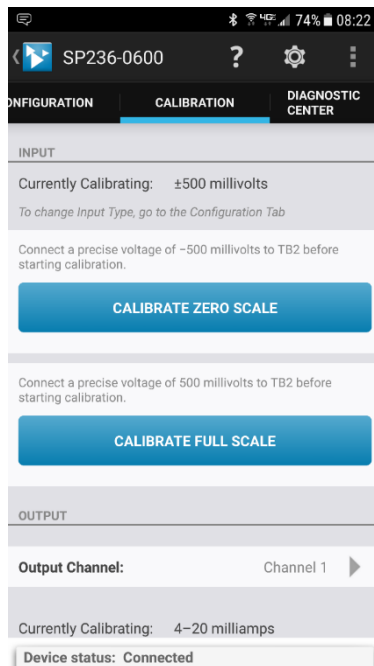

Input Calibration

If you have setup your unit and encounter excessive error, you may click the Calibration tab to display the Calibration control screen shown at left, which presents Input calibration controls first, followed by Output calibration controls as you scroll down the page.

IMPORTANT: The transmitter has already had its input & output channels factory calibrated with high precision. If you attempt to recalibrate the input or outputs, you may degrade its performance if done improperly, or by using low grade equipment. Consider recalibration carefully.

The selected input range being calibrated is indicated at the top. The software does not use your scaled sub-range zero to calibrate, but the zero of the nominal range selected. Some sub-ranges have their calibration extrapolated from the calibration of a larger native range. Calibrate the largest native range first to keep its recalibration from overwriting any sub-range calibration. These transmitters have two input terminals specific to input ranges--be sure to connect your input signal to the proper terminals.

For input zero calibration, connect a precise input signal level for the zero of your range, then tap the **[CALIBRATE INPUT ZERO]** button one time to set the input ADC level to its input range zero (0%) point.

For full-scale calibration, connect a precise input signal level for the full-scale value of your range, then tap **[CALIBRATE INPUT FULL-SCALE]** one time to set the input ADC level to its input range full-scale (100%).

The device status at the bottom of the page will report if the calibration was sent successfully.

Quick Overview – Android Reconfiguration...continued

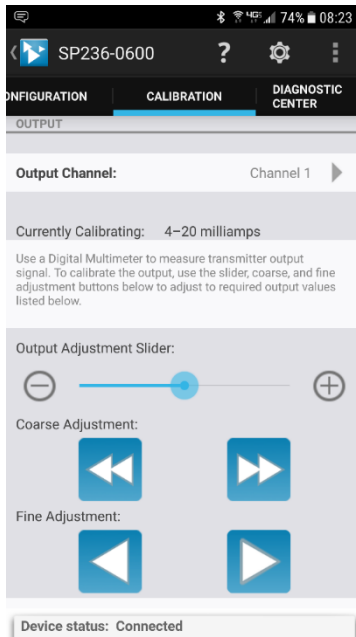

Output Calibration (Each of Two Outputs)

Scroll down the Calibration page to access the Output Calibration controls: output channel selector, adjustment controls, and the **[CALIBRATE OUTPUT ZERO]** and **[CALIBRATE OUTPUT FULL-SCALE]** buttons.

First select the Output channel to calibrate, and its output range will be displayed along with some instructions on how to proceed.

For Output Zero calibration, use the output adjustment slider and the coarse and fine adjustment controls to precisely set your output zero level while precisely monitoring your output signal. Be sure to use a meter with an accuracy at least 4x better than the signal you are measuring for best results. Note that the output adjustment controls temporarily remove control of the output from the input to accomplish calibration (control of the output level returns to the input signal after 30 seconds).

Once your output level is precisely set to its zero point (4.000mA for this transmitter), tap the **[CALIBRATE OUTPUT ZERO]** button one time to set the output DAC level (its corresponding digital count) to correspond to the zero (0%) of your output range.

For Full-Scale calibration, use the output adjustment slider and the coarse and fine adjustment controls to precisely set your output full-scale level while precisely monitoring your output signal. Be sure to use a meter with an accuracy at least 4x better than the signal you are measuring for best results. Note that the output adjustment controls temporarily remove control of the output from the input level to accomplish calibration (control of the output level returns to the input signal after 30 seconds).

Once your output level is precisely set to its full-scale level (20.000mA for this transmitter), tap the **[CALIBRATE OUTPUT FULL-SCALE]** button one time to set the output DAC level (its corresponding digital count) to correspond to the full-scale (100%) level of the output range.

Repeat the Output Calibration of zero and full-scale for the second output as required by selecting the opposite channel.

If following calibration, your output acts erratic or appears imprecise, you may need to repeat input or output calibration, being very careful to take accurate measurements and input correct signal levels. If you are measuring voltage across an output load resistance to measure the current level (recommended), make sure that you use exact resistance when calculating the measured loop current. When rescaling I/O, make sure that you have adequate I/O span, as “too-tight” input or output spans will have diminished resolution and magnify error.

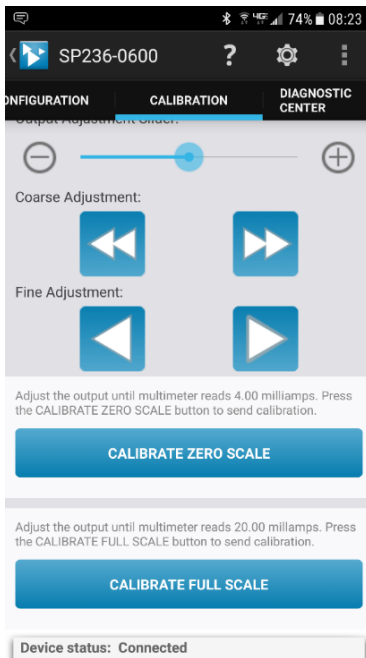

Quick Overview – Android Reconfiguration...continued

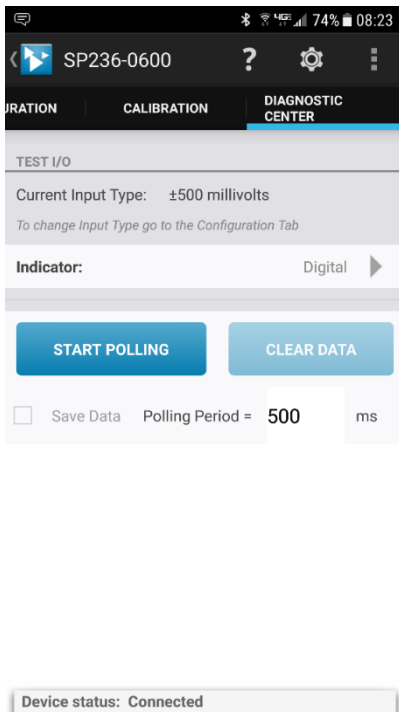

Performing Diagnostics (Polling & Trending the Input)

The Diagnostic Center screen tab is shown at left and used to verify input (ADC) operation of your transmitter. This page can be used to poll the input data and display its value or graph the input data and trend its value. The input type currently set is shown at the top of the screen (the input value, not the scaled input value is polled).

Select the Indicator pointer to set your desired indication to “Digital” (value) or “Graph” (trend).

You can specify a polling period to set the interval between polled readings by over-typing the value in the Polling Period field.

Start polling the input by tapping the [**START POLLING**] button.

Clear the polling data by tapping [**CLEAR DATA**].

Check the “Save Data” box if you wish to log the polled values to a CSV (Comma Separated Value) data file for reference.

Note the Communication Status of the device is indicated at the bottom of the screen.

Quick Overview – Windows



Click **“Open”** to connect to the DT235-0600 and your screen will look like:

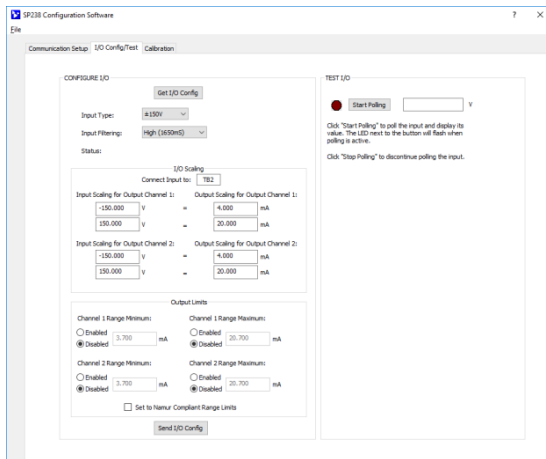
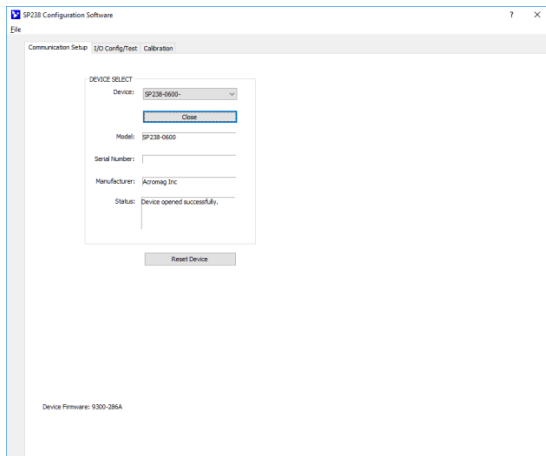

For detailed configuration and calibration procedures, see the **Operation Step-By-Step** section of the **Technical Reference** on page 21 of this manual.

In addition to the Android Agility mobile app, this transmitter can be optionally configured and calibrated via its USB Configuration Software and a USB connection to a Windows PC or laptop. The configuration software can be downloaded free of charge from our web site at <https://www.acromag.com>. This software is also included on a CDROM bundled with the Configuration Kit TTC-SIP (see Accessories section). For the DT235 model, look for program DT235Config.exe. This software is compatible with Windows 7 or later versions of the Windows operating system.

The initial configuration software screen for the DT235 model is shown at left after clicking [Open] to open communication with a connected module. The Configuration screen is divided into three pages as follows: Communication Set up, I/O Config/Test, and Calibration. A short description of each of these pages follows.

Communication Setup– First Select/Connect to Unit Here

- Select from connected transmitters using the Device scroll field and Open/Close communications with them.
- Display the Model, Serial Number, and Manufacturer of the connected transmitter, and report connection Status, or reset a connected unit.

I/O Config/Test – Reconfigure and/or Test the Unit Here

- You can click the **[Get I/O Config]** button to retrieve the I/O configuration of the currently connected transmitter.
- Select RTD Platinum, Copper, Nickel, or Resistance Input Type.
- Select the Input Range: RTD alpha value, or resistance range.
- Select the Configuration: Four-wire, Three-wire, or Two-wire.
- Select the level of digital filtering: High, Medium, Low or None. Note: The corresponding I/O response times are listed in parenthesis next to the filter selection.
- Select the Break Direction: Under-range or Over-range.
- Select the software temperature units °F or °C.
- Enter the I/O Scaling and specify the input temperatures to correspond to input Zero and Full-Scale of range that will drive the 4mA and 20mA output levels.
- You may set your own output range limits or enable Namur limits that differentiate fault levels from over/under detents.
- View the unit’s communication status in the Status field.
- Submit the configuration settings to the transmitter by clicking the **[Send I/O Config]** button to write the settings to the non-volatile EEPROM memory.

Quick Overview - Windows..

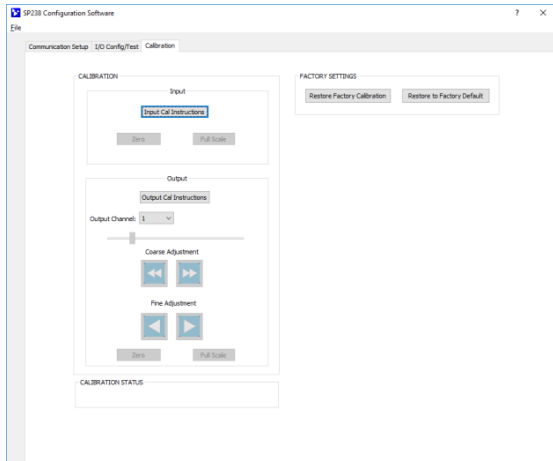
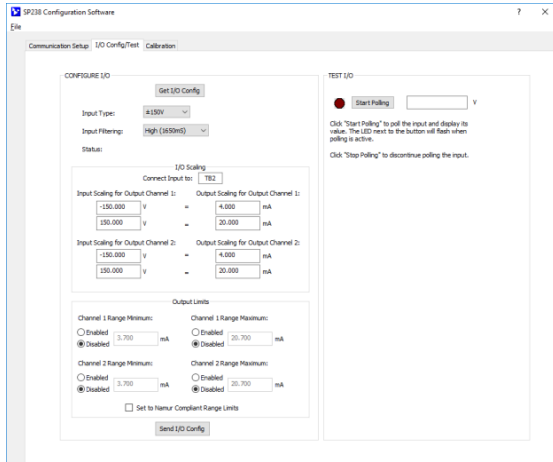

HELP – You can press F1 for Help on a selected or highlighted field or control. You can also click the [?] button in the upper-right hand corner of the screen and then click to point to a field or control to get a Help message pertaining to the item you pointed to.

TEST I/O - Optionally, Verify Unit Operation Here

After making CONFIGURE I/O changes, I/O Scaling, setting Output limits, and Sending your configuration to the unit, you can TEST I/O and Start/Stop Polling the input channel, as required to check your input readings.

- Click [**Start Polling**] to periodically read your input channel and validate its operation. Click [**Stop Polling**] to stop polling the input channel. Note the simulated red lamp left of the button flashes slowly when the software is polling the input channel.

CALIBRATION - Calibrate the Input and/or Output if Needed

The unit has already been factory calibrated, but if you encounter excessive error, you can click the Calibration tab to display the Calibration control page shown in the screen at left. To calibrate the Input or Output stage of this model, simply click the respective Input or Output “Instructions” button to get started and follow the on-screen prompts.

Input...

Set the Input Range to calibrate on the I/O Config/Test page and click [**Send I/O Config**] before attempting calibration. On the Calibration page, click the [**Input Cal Instructions**] button to begin input calibration.

When you click the [**Zero**] or [**Full Scale**] buttons of CALIBRATION - Input, you will be prompted to apply a current at TB1, or voltage level at TB2. Once you have applied the signal to the correct input terminals, click [**OK**] of the prompt to calibrate it and follow the on-screen instructions.

Output...

Click [**Output Cal Instructions**] to begin output calibration. You will be prompted to adjust the input as required to drive the output to precisely 4.000mA (Zero), or 20.000mA (Full-Scale). Once the output is set to zero or full-scale, you simply click the corresponding [**Zero**] or [**Full-Scale**] button of CALIBRATION – Output to set the output zero or full-scale endpoint.

Factory Settings (In Case of Trouble or for Sanitation Purposes)

- Restores a transmitter to its original factory calibration.
- Restores a transmitter to its initial factory configuration.

You can click [**Restore ...**] buttons if you misconfigure or improperly calibrate a transmitter such that its operation appears erratic.

Calibration Status (Bottom of Screen)

- Displays communication status messages for the calibration process.

The CALIBRATION STATUS field at the bottom of the screen will display status messages relative to calibration.

TECHNICAL REFERENCE

OPERATION STEP-BY-STEP

Connections

This section will walk you through the Connection-Configuration-Calibration process step-by-step. But before you attempt to reconfigure or recalibrate this transmitter, please make the following electrical connections

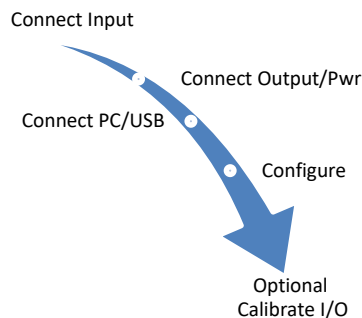

NOTE: For calibration, the input source, output meter, and load resistor (for current output) must be accurate beyond the transmitter specifications, or better than $\pm 0.1\%$. A good rule of thumb is to ensure that your equipment accuracy be four times better than the rated accuracy you are trying to achieve with this transmitter.

- 1. Connect Inputs:** Refer to Input Connections on page 7-9 for your model. For DT235 models, connect a precision resistance decade box to the input at TB1 and TB2 according to the RTD configuration you will be using (Refer to Sensor Input Connections). The resistance source must be adjustable over the nominal input range for zero and full-scale. All input types share the same wiring and procedure for calibration.
- 2. Connect Output/Power (each Output):** Refer to Output/Power Connection of page 10 and wire an output current loop to the transmitter as illustrated (two loops if you are using both channels). You will need to measure the output current accurately at each output to calibrate the unit. You could connect a current meter in series in each output loop to read the loop current directly (not recommended). Alternatively, you could simply connect a voltmeter across a series connected precision load resistor in each loop, and accurately read the output current as a function of the IR voltage drop produced in the resistor (recommended). In any case, be sure to power each loop with a voltage that is minimally greater than the 7V required by the transmitter, plus the IR drop of the wiring and terminals, plus the IR drop in the load (be sure to use a current level that considers the over-scale current as follows: Loop Voltage = $7V + 0.024 * R_{load}$ with negligible line drop). For this model, output loop 1 powers the unit's microcontroller and input channel 1 while output loop 2 powers only input channel 2. You must apply power to at least output loop 1 in order to reconfigure or calibrate the unit.
- 3. Connect to PC via isolated USB:** Refer to USB Connection on page 13 and connect the transmitter to the PC using a USB isolator and cables provided in the Configuration Kit TT-SIP. Optionally, you could instead connect the unit to an Android smartphone or tablet running the Agility mobile app with a USB-OTG cable.

Now that you have made your input, output/power, and USB connections, and you have applied power to your output loops, you can execute the DT235Config.exe software to begin configuration of your unit (this software is compatible with Windows 7 or later versions of the Windows operating system) or start the Agility mobile app (Android only).

Configuration

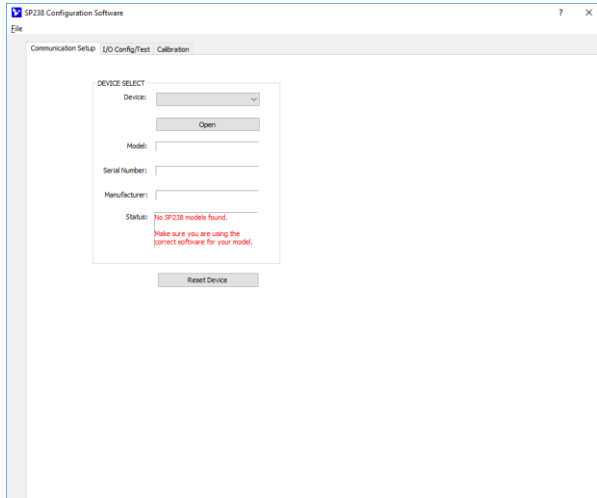

After executing the Acromag Configuration software for your model, a screen like that shown at left will appear **if you have not already connected to your transmitter via USB** (note fields are blank and red status message appears).

Connect your Windows PC to the unit via USB and its model-serial information will appear in the Device select scroll field as shown in the second screen at left.

If you are connected to more than one unit via a USB hub, you can use the Device scroll field to select another unit using the serial number suffix of the Device Model to discern one unit from another.

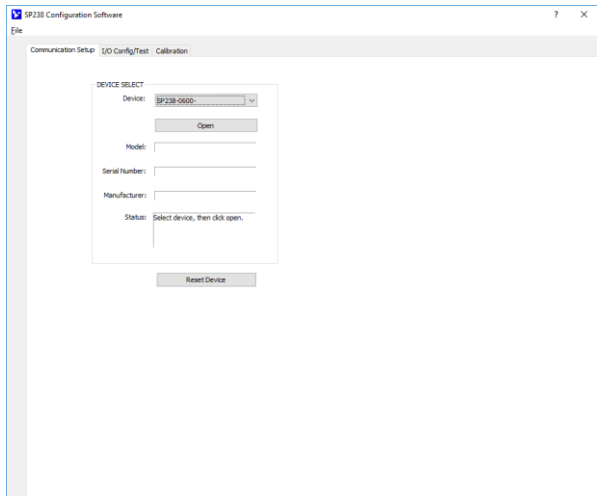

Once you have selected a device, click the **[Open]** button to open communication with the unit.

After clicking **[Open]**, the selected unit's Model, Serial Number, Manufacturer, and connection Status will be displayed as shown in the third screen at left.

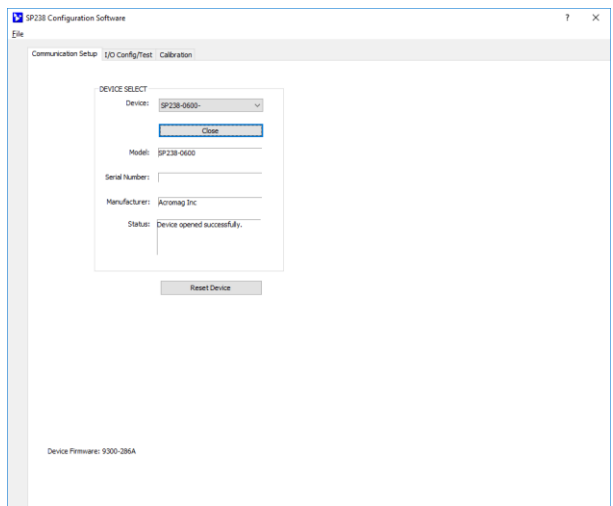

Configuration...

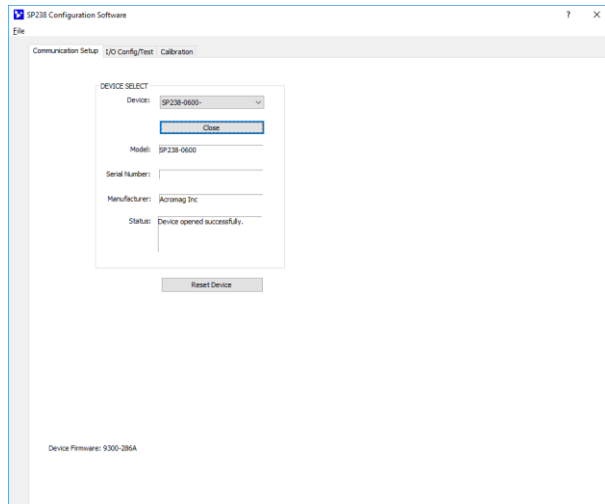

After you connect USB and “Open” communication with a unit, the Status field indicates “Device opened successfully” as shown in first screen at left.

At this point, you can click the “I/O Config/Test” tab to begin configuring the unit, or to optionally test its operation.

Note that you should already have loop power connected in each output loop of the transmitter. You will not be able to calibrate a unit or test it without loop power also applied to at least one output.

When you select “I/O Config/Test”, the software retrieves the unit’s current configuration and displays it in the I/O Config/Test page shown on the second screen at left. If you make changes to this screen, but do not Send them to the unit, you can retrieve the module’s current configuration by clicking the **[Get I/O Config]** button at the top of this screen.

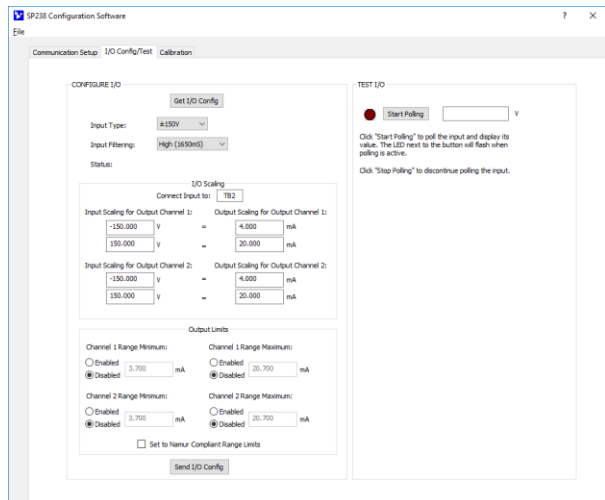

DT models have two input channels with separate inputs at TB1 and TB3.

I/O Config/Test (Configure and/or Test the Unit Here)

- You can click the **[Get I/O Config]** button to retrieve the I/O configuration of the connected transmitter.
- Select the Input Type: Platinum, Copper, Nickel, or Resistance for each channel at TB1 and TB3.
- Select the Input Range: RTD alpha or resistance.
- Select the Configuration: 4-Wire, 3-Wire, or 2-Wire.
- Set the digital filter level: High, Medium, Low, or None. Response time varies with filter selection and is indicated in parenthesis next to your selection.
- Set the Lead Break detent: Under or Over-Range.

Configuration...

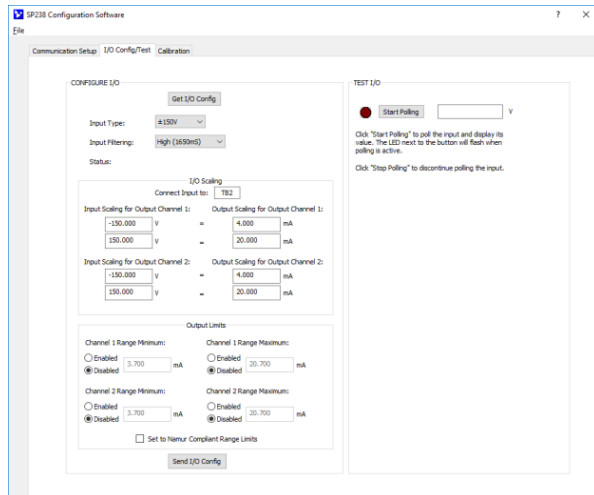

HELP – You can press **[F1]** for Help on a selected or highlighted field or control. You can also click the **[?]** button in the upper-right hand corner of the screen and click to point to a field or control to get a Help message pertaining to the item you pointed to.

- For each output, set the input/output scaling by entering the input zero and full-scale signals to drive 4mA and 20mA at the output (some under/over-range is always included).

You must be careful not to reduce a nominal input range too much, as resolution will diminish 1 bit each time you halve the range, potentially magnifying noise and error.

You can optionally swap input levels to configure a reverse acting output response if desired.

If the input zero and full-scale points are chosen too close together, performance will be degraded.

Once you have made your configuration selections, click the **[Send I/O Config]** button to write them to the module. You can read the status of your communication with the module in the Configure I/O Status field. Alternately, you could click **“File”** in the upper left-hand corner to save the settings to a file on your PC, for reference later, or for duplicating your configuration on other modules.

At this point, you can test the module’s operation by clicking the **[Start Polling]** button to trigger the software to periodically read the input and display its value in the field to the right of this button. Note the simulated lamp next to the button flashes slowly each time it samples the input. Click the **[Stop Polling]** button to stop polling the input channel before moving onto the next page.

Calibration (Optional)

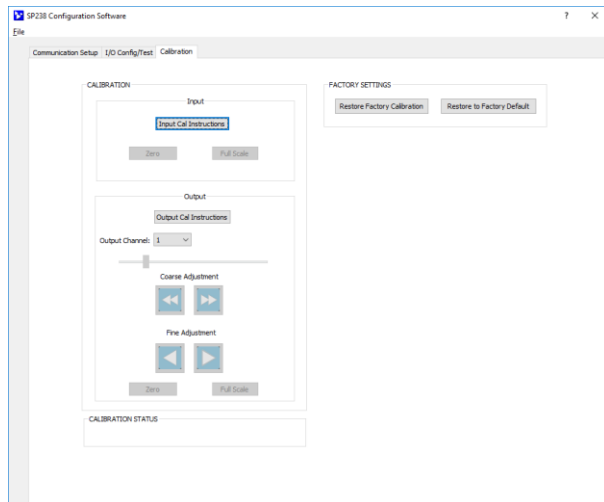

CAUTION-Input Calibration: You must input values within your selected input range. Driving input levels outside of the selected input range will not be acceptable for calibration of zero or full-scale. Since input levels cannot be validated during field calibration, incorrect signal levels will produce an undesired output response.

This unit has already been factory calibrated. If you have configured your unit and encounter excessive error, you can click the Calibration tab to display the Calibration control page shown at left.

IMPORTANT: This unit has already had its input and output channels factory calibrated with a high level of precision. If you attempt to recalibrate the input or an output channel, you could degrade its performance if you do it improperly, or you use lower grade equipment. Consider your decision to recalibrate carefully.

Calibration of this is a two-part process initiated by clicking the respective Input or Output [...Instructions] button to get started and follow the on-screen prompts.

CALIBRATION - Input

Before attempting to recalibrate the input, first set the Input Range to calibrate from the "I/O Config/Test" page. Additionally, make sure you write your selections to the unit by clicking the [Send I/O Config] button of that page.

Click the [Input Cal Instructions] button to begin input calibration and enable the Input [Zero] and [Full-Scale] buttons.

For the DT235 example, click the Input [Zero] button and you will be prompted to input the minimum value of your selected input range at the appropriate input channel (note that it uses nominal range endpoints, not scaled range endpoints). If you have selected a DC Current range, you must drive -20mA, 0mA, 4mA, or -1mA at TB1 (the upper input terminal block), depending on the Input Range selected. If you have selected a DC voltage range, you would drive -0.5V or 0V to TB2 (the lower input terminal block). The software does not use your scaled zero, but the zero of the nominal input range selected. Once you input the zero precisely, click the [OK] button of the prompt to calibrate zero and then follow the on-screen prompt.

For DT235, click the Input [Full-Scale] button and you will be prompted to input the maximum value of your selected input range at the appropriate input channel. If you have selected a DC Current range, this will be 20mA or 1mA at TB1, depending on the Input Range selected. If you have selected a DC voltage range, this will be 0.5V at TB2. The software does not use your scaled full-scale, but the full-scale of the nominal input range selected. Once you input full-scale precisely, click the [OK] button of the prompt to calibrate full-scale and then follow the on-screen prompt.

Calibration...

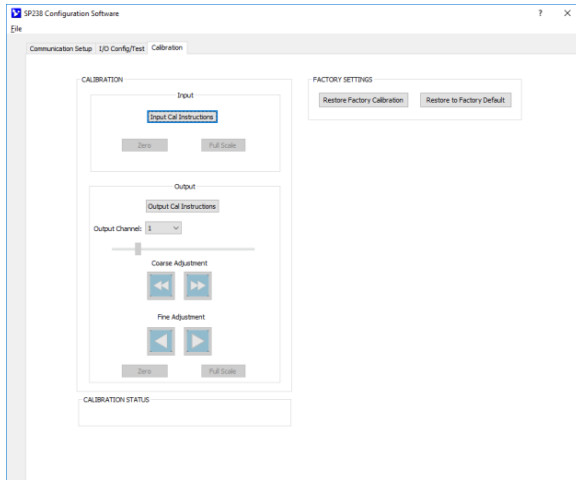

CALIBRATION – Each Output

Click the **[Output Cal Instructions]** button to begin output calibration and enable the Output **[Zero]** and **[Full-Scale]** buttons.

First adjust the input signal as necessary to drive the output current to precisely 4.000mA. Be sure to measure this level accurately or performance will be degraded. After driving the output to 4.000mA, click the Output **[Zero]** button of the Calibration Output section to calibrate the output zero level.

Next adjust the input signal as necessary to drive the output current to precisely 20.000mA. Be sure to measure this level accurately or performance will be degraded. After driving the output to 20.000mA, click the Output **[Full-Scale]** button of the Calibration Output section to calibrate the output full-scale level.

Repeat this process for the second output channel.

If following calibration, your output acts erratic or appears imprecise, you may need to repeat input or output calibration, being very careful to take accurate measurements and input correct signal levels. If you are measuring voltage across an output load resistance to measure the current level in an output (recommended), make sure that you use exact resistance when calculating the measured loop current. When rescaling, make sure that you have adequate input span, as “too-tight” input spans have diminished resolution and will magnify error.

Factory Settings

You can use the **[Restore Factory Calibration]** button to restore the transmitter’s original factory calibration if you think you made an error during recalibration, have degraded its performance, or if the I/O channel appears erratic.

You can use the **[Restore to Factory Default]** button to return the unit to its original factory state (see Specifications Reference Test Conditions) and configuration settings. This does not restore calibration, only configuration. Alternately, this button can be used as a sanitation tool to restore the unit to its initial configuration.

Calibration Status

This field displays calibration status messages like “No Error”, “Transfer Error”, and “Timeout Error” during calibration. If you encounter a Transfer or Timeout Error, you should repeat the calibration process.

RTD Resistance versus Temperature

TEMP °C	Temperature in Ohms					
	100Ω Platinum RTD				120Ω Nickel RTD (α = 0.006872)	10Ω Copper RTD (α = 0.004274)
	α = 0.00385	α = 0.00390	α = 0.003911	α = 0.00392		
-200	18.520	17.396	17.260	17.079		1.058
-150	39.723	38.903	38.789	38.648		3.113
-100	60.256	59.721	59.638	59.543		5.128
-50	80.306	80.044	80.000	79.952	86.17	7.104
-40	84.271	84.061	84.026	83.988	92.76	7.490
-30	88.222	88.065	88.038	88.010	99.41	7.876
-20	92.160	92.056	92.038	92.019	106.15	8.262
-10	96.086	96.034	96.025	96.015	113.00	8.649
0	100.000	100.000	100.000	100.000	120.00	9.035
+10	103.903	103.954	103.963	103.973	127.17	9.421
+20	107.794	107.896	107.915	107.934	134.52	9.807
+30	111.673	111.827	111.855	111.883	142.06	10.194
+40	115.541	115.745	115.783	115.821	149.79	10.580
+50	119.397	119.652	119.700	119.747	157.74	10.966
+60	123.242	123.547	123.605	123.661	165.90	11.352
+70	127.075	127.429	127.498	127.563	174.25	11.738
+80	130.897	131.300	131.379	131.454	182.84	12.125
+90	134.707	135.160	135.249	135.333	191.64	12.511
+100	138.506	139.007	139.107	139.200	200.64	12.897
+150	157.325	158.066	158.222	158.360	248.95	14.828
+200	175.856	176.828	177.044	177.226	303.46	16.776
+250	194.098	195.294	195.574	195.799	366.53	18.725
+300	212.052	213.463	213.811	214.079	439.44	
+350	229.716	231.336	231.756	232.065		
+400	247.092	248.912	249.409	249.758		
+450	264.179	266.192	266.769	267.157		
+500	280.978	283.175	283.836	284.263		
+550	297.487	299.862	300.611	301.075		
+600	313.708	316.252	317.094	317.594		
+650	329.640	332.346	333.284	333.820		
+700	345.284	348.143	349.181	349.752		
+750	360.638	363.644	364.787	365.391		
+800	375.704	378.848	380.099	380.736		
+850	390.481	393.756	395.119	395.788		

NOTE: 200Ω, 500Ω, and 1000Ω Platinum RTD resistances can be calculated based on the table above. For 200Ω Platinum, multiply the resistances in the table by 2. For 500Ω Platinum, multiply the resistances in the table by 5. For 1000Ω Platinum, multiply the resistances in the table by 10.

NOTE: Alpha (α) is used to identify the RTD curve and its value is derived by dividing the sensor resistance at 100°C (boiling point of water) minus the sensor resistance at 0°C (freezing point of water), by the sensor resistance at 0°C, then by 100°C ($\alpha = [R_{100^\circ\text{C}} - R_{0^\circ\text{C}}] / R_{0^\circ\text{C}} / 100^\circ\text{C}$). For Pt100Ω α=0.00385, this is 38.5Ω/100.0Ω/100°C, or 0.00385Ω/Ω/°C.

BLOCK DIAGRAM

TWO-WIRE OUTPUT LOOP-POWERED 7-32V DUAL TRANSMITTER
 DT SERIES PROVIDES TWO ISOLATED TRANSMITTERS IN A 17.5MM WIDE PACKAGE
 EACH TRANSMITTER CHANNEL HAS SAME FRONT-END AS SIMILAR TT235 MODELS
 EACH TRANSMITTER CHANNEL OUTPUT DAC IS DIGITALLY ISOLATED

DT235-0600 SIMPLIFIED SCHEMATIC
 (FILTERING AND DETAIL OMITTED FOR CLARITY)

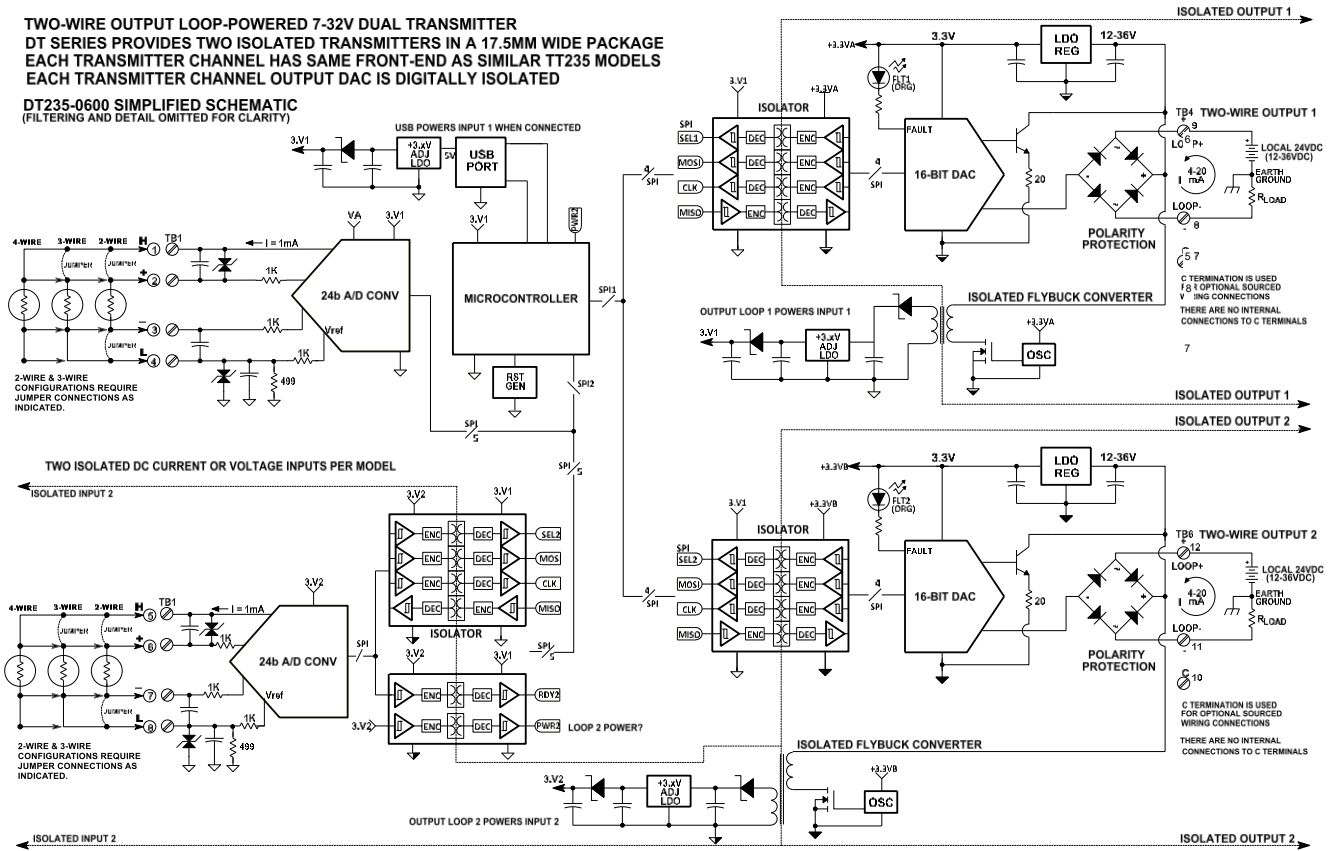

How It Works

Key Points of Operation

- Loop Powered
- Inputs/Outputs individually isolated.
- Output loop is Not Polarized.
- Input circuit common is connected to USB ground.
- USB powers a portion of the input circuit when connected, but not the output. This allows demo reconfiguration without powering output loop 1.

This transmitter uses a microcontroller and two high-resolution A/D's to convert the input signals to a digital SPI signal isolated via digital isolators and transmitted to isolated current DAC's in each output. Power for the common isolated input 1 side of the circuit is provided via an isolated fly-back converter operating in parallel with output loop 1. Setup involves selecting the input type, filter levels, and scaling input range endpoints to each output's range end points. Output scaling can be optionally done in reverse to produce a reverse acting output. You may even scale inputs & outputs differently for each channel. The maximum linear over-range output is approximately 24mA, the minimum under-range is 3.7mA. Refer to the block diagram to gain a better understanding of how this transmitter works. Note the input 1/USB, input 1, and each output/power circuit are isolated from each other. The USB port ground is common to the input 1 circuit ground. The USB port ground of most PC's is also common to the USB cable shield and earth ground and input sensors could be grounded or ungrounded. For this reason, it is recommended that USB signals be isolated when connecting to a PC to prevent a ground loop from occurring between the PC earth ground and a grounded input sensor, which would have the negative effect of pulling the input 1 bias supply to ground, clipping the negative portion of the bipolar input 1 range.

TROUBLESHOOTING
Diagnostics Table

*Before attempting repair or replacement, be sure that all installation and configuration procedures have been followed and that the unit is wired properly. Verify that power is applied to the loop and that your loop power supply voltages are sufficient to supply over-scale current into the loads (MIN 0.020*Rload), plus 7V MIN at the unit terminals, plus any line drop.*

If your problem still exists after checking your wiring and reviewing this information, or if other evidence points to another problem with the unit, an effective and convenient fault diagnosis method is to exchange the questionable unit with a known good unit.

Acromag’s Application Engineers can provide further technical assistance if required. Repair services are also available from Acromag.

POSSIBLE CAUSE	POSSIBLE FIX
<i>Software Does Not Detect Unit or Communication Set up Screen is Blank...</i>	
USB is not connected between unit and host PC.	Verify USB cable from USB isolator is plugged into the unit and the isolator. Verify that USB cable from PC is also plugged into the PC USB port and into the isolator.
USB has not enumerated the device.	Use the reset button on the Acromag USB isolator to trigger reenumeration of the transmitter, or simply unplug and re-plug the USB cable to the transmitter.
Communication or power was interrupted with USB connected and config software running.	Close the current connection with the software, then select and re-open the transmitter for communication (or simply exit the Configuration software and reboot it).
<i>Cannot Communicate with Transmitter via USB...</i>	
<i>Unit fails to operate or exhibits an output shift...</i>	
<i>Output shifts off-range when you connect USB...</i>	
A missing USB Isolator could cause a ground loop between a grounded input signal/sensor and earth ground at the connected Personal Computer’s USB port.	Isolated splitters and transmitters can be used with grounded or ungrounded inputs, but you can only connect grounded sensors if the USB signals are also isolated. Without USB isolation, a ground loop is created between a grounded input and earth ground of the PC USB port. This module’s input is biased 1.25V off input ground to allow it to process negative-going signals. Earth ground applied via the non-isolated USB connection with an earth grounded sensor would clip the input bias and truncate the negative signal range. It’s best to connect to USB via a USB isolator for this reason and for increased safety and noise immunity. Use an isolator like the Acromag USB-ISOLATOR. Otherwise, use a battery powered laptop to configure the transmitter which does not normally earth ground its USB port.
<i>Output is Erratic, not operational, or at Wrong Value...</i>	
Is your output loop power supply at the correct level for your load? Is Output Fault LED blinking?	Verify loop voltage and level in each output. Ideally, your supplies must be adequate to provide 7V MIN to the transmitter, plus the IR drop in the load, plus the IR drop in the lead wires, and all at the maximum loop current (>20mA).

Diagnosics Table...

POSSIBLE CAUSE	POSSIBLE FIX
<i>Cannot Calibrate Input Channel...</i>	
Are inputs wired properly?	Check that input is wired to correct \pm input terminals using the correct polarity for your model.
Are you wired to the correct input terminals for your desired range?	TB1 and TB3 support multiple input ranges (refer to specifications).
<i>Cannot Calibrate the Output or Cannot Test the Unit...</i>	
Loop power ON to the unit?	The unit receives power from both USB (when connected), and the output loop power supplies. While you can configure a unit over USB without loop power applied, a loop power connection is required to test operation or calibrate the unit.
<i>Unit drives a low current, but fails to drive higher output current...</i>	
Loop supply voltage is too low to support current into the loop-load or the loop-load resistance is too large for the current level. Does the output fault LED blink at the higher current?	Check power voltage level. Make sure it is <u>at least</u> 7V plus $0.02 \times R_{load}$. If transmit distance is especially long, then it must have added voltage to support the IR drop in the wire. Ideally, the voltage should also have ample overhead to drive the load at the maximum upscale output current > 20mA.
<i>Cannot Measure Input Voltage or Input Current...</i>	
Your input may be wired to the wrong terminal.	On the DT235 for example, DC Current is input to TB1/TB3-1 (leftmost terminal), while voltage is input to TB1/TB3-3 (rightmost terminal). Only voltages up to $\pm 1V$ may connect to TB1/TB3-1 of the DT235. If you mistakenly wire these lower voltage signals to TB2 of the DT235, your resolution will be poor as TB2 has a 12.52:1 divider at its input (TB1 is the upper terminal block). Likewise, if you connect $\pm 10V$ or $\pm 5V$ to TB1/TB3-1/ of the DT235, you'd drive it into over/under-range.
<i>For input step, output appears to make 2 steps to reach its final value...</i>	
For a step change in an input, the input A/D typically needs two input samples to ramp up to its final level.	When you step the input signal, it takes two samples for the A/D to ramp up to its final value, and this is evident when using a scope to examine the output transition in response to a step change at the input, which appears to make two steps to arrive at its final level.

Diagnostics Table...

<i>Output goes above Over-Range (20.7mA), or below Under-Range Limit (3.7mA)...</i>	
If you have selected Namur compliant output limits, the input has gone outside of its linear operating range of 3.7mA to 20.7mA and this indicates the fault condition of an open sensor or broken lead. It could also occur due to contention between earth ground at the PC USB port and the input 1 sensor, or it may indicate failed communication with the output DAC (a firmware problem).	Check the input signal with respect to its range and reduce or increase it as required to drive the output current within its linear operating range. A fully upscale or down-scale signal can be driven by a sensor fault, such as an open or broken sensor lead, a ground fault with the input 1 sensor, or a DAC communication error. Check the wiring of your input sensor. If you are not isolating USB, check for a ground loop between a grounded sensor and earth ground of the PC USB port.
<i>Output holds last value when I connect USB...</i>	
Unit is awaiting initialization via its configuration software used to set it up, configure it, and calibrate it.	Boot the configuration software to regain operation. The USB port is intended for set up and configuration of the module and it should not be left connected to USB without also booting the USB software.
<i>Output Fault (FLT) LED blinks...</i>	
The corresponding output loop voltage is too low to support the loop load current, or the load resistance is too high for the loop supply voltage level. Note this LED will blink one time if loop power is turned off.	Check the corresponding output loop voltage level and wiring. Verify your output load resistance is less than $R=(V_s-7)/0.02x$. Note that an isolated 2-wire output is earth grounded at the V_s supply minus lead (load minus), not the transmitter output.

Service & Repair Assistance

This unit contains solid-state components and requires no maintenance, except for periodic cleaning and transmitter configuration parameter (zero and full-scale) verification. The enclosure is not meant to be opened for access and can be damaged easily if snapped apart. Thus, it is highly recommended that a non-functioning transmitter be returned to Acromag for repair or replacement. Acromag has automated test equipment that thoroughly checks and calibrates the performance of each transmitter and can restore firmware. Please refer to the Acromag Service Policy and Warranty Bulletin, or you may contact Acromag for complete details on how to obtain repair or replacement.

ACCESSORIES

Software Interface Package



Software Interface Package/Configuration Kit – Order TT-SIP

- USB Signal Isolator
- USB A-B Cable 4001-112
- USB A-mini B Cable 4001-113
- Configuration Software CDROM 5040-944

This kit contains all the essential elements for configuring TT/DT/SP family Transmitters/Splitters. Isolation is recommended for USB port connections to these devices and will block a potential ground loop between your PC, a grounded input, or a grounded current loop. A software CDROM is included that contains the Windows software used to program the transmitter.

USB Isolator



USB Isolator – Order USB-ISOLATOR

- USB Signal Isolator
- USB A-B Cable 4001-112
- Instructions 8500-900

This kit contains a USB isolator and a 1M USB A-B cable for connection to a PC. This isolator and cable are also included in TT-SIP (see above).

USB A-B Cable



USB A-B Cable – Order 4001-112

USB A-B Cable 4001-112

This is a 1 meter, USB A-B replacement cable for connection between your PC and the USB isolator. It is normally included with the TT-SIP Software Interface Package and with the isolator model USB-ISOLATOR.

USB A-mini B Cable



USB A-mini B Cable – Order 4001-113

- USB A-mini B Cable 4001-113

This is a 1 meter, USB A-miniB replacement cable for connection between the USB isolator and the TT/SP transmitter/splitter. It is normally included in TT-SIP.

Note that software for all TT/SP Series models is available free of charge, online at www.acromag.com.

ACCESSORIES

USB OTG Cable



USB OTG Cable – Order 5028-565

- USB OTG Cable 5028-565

This is a 6-inch, USB On-The-Go cable for connection between the USB A-mini B Cable and an Android mobile phone or tablet that support USB. It is required to use the Acromag Agility™ Config Tool App for Android OS reconfiguration of this transmitter.

Note that the Acromag Agility™ Config Tool is available free of charge, online at the Google Play store.

End Stops

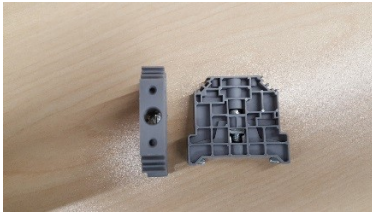

Two End Stops – Order 4001-252

- Two 1027-222 End Stops for 35 mm DIN Rail mounting

For hazardous location installations (Class I, Division 2 or ATEX/IECEx Zone 2), you can use two end stops (Acromag 1027-222) to help secure modules to 35mm DIN rail (not shown).

SPECIFICATIONS

Model Numbers

*DT235-0600 Dual Transmitter
Two Isolated RTD/ Ω Inputs
Two-Wire Loop-Powered Outputs
CE Approved
Includes cULus Class I, Div 2,
ATEX/IECEX approvals*

*Custom calibration to your
specifications can be added as a
separate line item at time of
purchase.*

The DT model prefix denotes a Dual Transmitter. Its 3rd digit “2” denotes a 2-wire loop-powered transmitter of the Acromag DT200 family. The trailing “35” digits denote an RTD/resistance input type. The “-0600” model suffix specifies a loop-powered unit with CE and cULus Class I, Division 2, ATEX/IECEX Zone 2 Approvals. Models normally mount on standard 35mm “T” Type DIN rail.

Optional factory calibration to your own specifications is ordered as a separate line item at time of purchase on a per unit basis. This requires the specification of model and input type, input range zero and full-scale range values, upscale/downscale break detection, input filter level (none, low, medium, or high). You can also specify a normal 4-20mA or reverse 20-4mA acting output with programmable or Namur compatible output range and clamping limits.

A standard model without adding custom factory calibration is calibrated by default to reference test conditions (see below). Field recalibration or reconfiguration of any transmitter options will require use of a TTC-SIP configuration kit, ordered separately (see Accessories section).

Inputs (Each)

This model has dual isolated inputs at TB1 and TB3 intended for RTD or resistance sensor connections.

This unit has three different operating modes: dual transmitter, single CH1 transmitter, and CH1 signal splitter.

Input Reference Test Conditions (each channel): 100 Ω Pt RTD, α = 0.00385; -200°C to 850°C input; Configuration = Three-wire; Filtering = Medium; Output = 4 to 20mA, Normal Acting; Output Load = 250 Ω . Break detection = Upscale; Ambient = 25°C; Power supply = 24VDC. Unit mounted upright on a DIN rail to allow free air flow from the bottom vent to pass through the unit and out the top vent.

Input Range & Accuracy: Models have separate input channels at TB1 & TB3. The input is processed differentially and ratiometrically by the A/D converter and may be scaled separately from its output with a smaller portion of the range driving the output.

Input Type	$^{\circ}\text{C}$ or Ω Spans in Range	Typical Accuracy
Pt 100 Ω	-200 $^{\circ}\text{C}$ to +850 $^{\circ}\text{C}$	$\pm 0.25^{\circ}\text{C}$
Pt 200 Ω	-200 $^{\circ}\text{C}$ to +850 $^{\circ}\text{C}$	$\pm 0.30^{\circ}\text{C}$
Pt 500 Ω	-200 $^{\circ}\text{C}$ to +850 $^{\circ}\text{C}$	$\pm 0.50^{\circ}\text{C}$
Pt 1000 Ω	-200 $^{\circ}\text{C}$ to +850 $^{\circ}\text{C}$	$\pm 1.00^{\circ}\text{C}$
Ni 120 Ω (Minco 7-120)	-80 $^{\circ}\text{C}$ to +320 $^{\circ}\text{C}$	$\pm 0.08^{\circ}\text{C}$
Cu 10 Ω (Minco 16-9)	-200 $^{\circ}\text{C}$ to +270 $^{\circ}\text{C}$	$\pm 1.00^{\circ}\text{C}$
Resistance (Linear)	0 to 25 Ω	$\pm 0.05\Omega$
	0 to 450 Ω	$\pm 0.10\Omega$
	0 to 900 Ω	$\pm 0.90\Omega$
	0 to 2250 Ω	$\pm 2.25\Omega$
	0 to 4500 Ω	$\pm 4.50\Omega$

Input Configuration: Four-wire (this has negligible lead-wire effect), three-wire with lead-wire compensation, and two-wire without lead-wire compensation.

Inputs...continued

Input Linearization: Preset for input RTD and linearized to temperature or ohms (resistor).

Input Excitation Current: Set to 0.1mA, 0.2mA, 0.5mA, 1mA typical, for Inputs 1000Ω, 500Ω, 200Ω, 100Ω & Nickel & Copper respectively. Current drift over temperature has negligible effect due to ratio-metric measurement technique (A/D reference derived from RTD excitation current).

Input Lead-Wire Compensation (3-Wire Sensor): This wiring configuration requires balanced input [+] and [L] sensor leads (leads of same size, length, & material type) to accomplish lead resistance compensation.

Input Lead-Wire Resistance Effect: Less than 0.001°C per Ω of unbalance, typical (4-Wire sensors), or 3.5°C per Ω of unbalance, typical (Pt100), 1.4°C per Ω of unbalance, typical (Ni), 25.5°C per Ω of unbalance, typical (Cu) for 2-Wire and 3-Wire sensors. Units will operate with a maximum lead resistance of 25Ω per lead.

Input Lead-Wire Break/Burnout Detection: Can be set to go to an over-range or under-range output detent for an open sensor or broken lead. Output clamp limits are programmable and can be set outside a linear operating range from ~3.7mA to 20.7mA (w/ Namur limits). Over-range output limits up to 24mA are possible depending on the input range and I/O scaling.

Input Analog to Digital Converter (A/D): Each input channel utilizes a 24-bit, Σ-Δ A/D converter, with only the first 16-bits used (Texas Instruments LMP90100MHE). To simplify I/O scaling, A/D measurements are normalized to a bipolar range count of ±25000 (see Input Resolution in Table 1 below).

Sampling Rate (A/D): Inputs sampled at a variable rate with filter as follows:

A/D SAMPLING RATE (SAMPLES/SECOND) PER INPUT FILTER				
MODEL	None	Low	Med	High
DT235	107.325sps	26.83125sps	6.71sps	0.83875sps

Input Impedance: 15.4MΩ, typical.

Input Overvoltage Protection: Inputs include Bipolar Transient Voltage Suppressors (TVS) and diode-clamping with series resistance and capacitive filtering.

Input Filtering: RC filtering plus digital filtering, optimized and fixed per input range and filter selection within the Σ-Δ ADC. See Normal Mode Noise Rejection and Output Response Time.

Input Noise Rejection (Common Mode): 101dB, typical with 100Ω input unbalance and no filtering.

Input Noise Rejection (Normal Mode): Varies with input filter level as follows:

Typical 60Hz Rejection per Input Filter Setting				
MODEL	None (dB)	Low (dB)	Med ¹ (dB)	High ¹ (dB)
DT235	13dB	25dB	> 80dB ¹	> 80dB ¹

¹**Note:** At medium and high filter settings, the heavily attenuated 60Hz signal cannot be measured due to 4th order filtering by the input ADC which adds 80dB minimum of rejection at frequencies between 47Hz and 61Hz.

Input Bandwidth: The frequency at which the DT235 output is attenuated 3dB is 16Hz with no input filter. See also Normal Mode Noise Rejection and Output Response Time.

Inputs...continued

Input Resolution: The ADC's of this model will each divide their input signal range into a digital number of parts that can be calculated using the expression for ADC counts as $32768 * R_{IN} * Gain / 499$, with Gain=1 for all input types except Copper RTD (Cu uses Gain of 16). R_{IN} refers to the resistance of the input sensor. Nominal range resolution is computed as the difference in the number of parts between the input range low endpoint and high endpoint as shown in the following table:

Input Type	α Alpha ¹	ADC Input Resolution
Pt 100 Ω , 200 Ω , 500 Ω , 1000 Ω	0.00385	1 part in 24425
	0.00390	1 part in 24714
	0.003911	1 part in 24812
	0.00392	1 part in 24868
Ni 120 Ω (Minco 7-120)	0.006872	1 part in 26569
Cu 10 Ω (Minco 16-9)	0.004274	1 part in 19384
Resistance (0 to 25 Ohms)	N/A	1 part in 26172
Resistance (450, 900, 2250, 4500 Ohms)	N/A	1 part in 29491

¹**Note (Table 2):** Alpha (α) is used to identify the RTD curve. Refer to "RTD Resistance versus Temperature" section for an explanation of alpha value. Because this transmitter allows a portion of its nominal range to be rescaled to the output, smaller ranges will proportionally diminish nominal resolution as the span is reduced. The effective I/O resolution of this transmitter from input to output will be the lowest resolution of the ADC itself, normalization to ± 25000 , or the output DAC (the output DAC resolution is 1 part in 46984 for 4-20mA).

Input Range Zero and Full-Scale Adjustment: Nominal input ranges are selectable (see above) and their range endpoints are adjustable over the full range of input temperature or resistance. The adjusted input Zero/Full-Scale signal levels must reside within nominal ranges and will be mapped to 0% and 100% of the output range. Keep in mind that input resolution will be diminished proportionally as the input range is reduced below nominal, and input error will also be magnified as the input span is reduced.

Outputs (Each)

Output Range: Output is 4 to 20mA DC nominal, linear with input temperature (RTD) or resistance (resistance input). Output has under-range capability down to 3.5mA, and over-range up to 24mA, depending on input range selected and I/O scaling. With Namur NE 43 limits selected, the linear under-range limit is ~ 3.7 mA, and linear over-range limit is ~ 20.7 mA, with fault detents set outside the linear signal range at ~ 3.5 mA (downscale) and $\geq \sim 21$ mA (upscale).

Output Accuracy: Accuracy is typically better than $\pm 0.05\%$ of span ($\pm 0.1\%$ Max) for nominal input ranges. Relative accuracy will vary with calibrated input and output span, and scaling. Accuracy includes the combined effects of repeatability, terminal point conformity, and linearization, but does not include sensor error.

Output Ripple/Noise: Less than $\pm 0.1\%$ of output span.

Note – High Speed Acquisition: Additional filtering at the load is recommended for sensitive applications with high-speed acquisition rates. For excessive 60Hz supply ripple, a 1 μ F or larger capacitor is recommended at the load. High frequency noise may be reduced or eliminated by placing a 0.1 μ F or 0.01 μ F capacitor directly across the load (this can also raise RF immunity).

Output...

CAUTION: Do not exceed 36VDC peak to avoid damage to the unit. Terminal voltage at/above 7V minimum must be maintained across the output during operation.

Output Ambient Temperature Effect: The combined effect of zero and span drift over temperature is better than ±0.008% of span per °C (±80ppm/°C) over the full ambient temperature range for reference test conditions (see Input Specifications).

Output DAC Resolution: Each output includes a 16-bit current DAC (Texas Instruments DAC161S997RGH) with current set to 24mA*COUNT/65536 (see Table 3). Its 4-20mA output will yield an output resolution of 54613-10923, or 1 part in 43690. Linear range limits are programmable or set to Namur limits near ~3.7mA (low) & ~20.7mA (upper), allowing you to discern an upscale or downscale lead break condition from the linear operating range. The effective I/O resolution of this transmitter will be the lowest of either the input, normalization, or the output.

Table 3: Output DAC Current Level & Digital DAC Count	
I-LOOP = 24mA*COUNT/65536	COUNT = 65536*I-LOOP/24mA
3.7mA	10103
4.0mA	10923
12mA	32768
20mA	54613
20.7mA	56525
23.9996mA	65535

Output Response Time: The max time per input filter setting measured for the output to reach 98% of its transition with a step change in the input signal while driving output current to a 250Ω load in series with a 24V loop supply.

Typical Output Response Time to 98% of Transition Per Input Filter			
None	Low	Medium	High
34ms	80ms	214ms	1238ms

Compute $R_{load} (Max) = (V_{supply} - 7V)/0.021A$ for 21mA output current. Refer to the table at right.

Output Power Supply: Output loop is powered from 7-32V DC SELV (Safety Extra Low Voltage), 24mA maximum. Loop voltage across the output must never exceed 36V, even with a shorted load. Set voltage level to provide a minimum of 21mA over-range current to the load (0.021*R typical), plus 7V across the output terminals, plus any interim line drop (long distances). Output terminals are not polarized (the ± output label designations of the enclosure are for reference only).

Output Power Supply Effect: Less than ±0.001% of output span effect per volt DC of supply change within rated limits for load.

Output Load Resistance Effect: Less than ±0.001% of output span effect for a ±100Ω change in load resistance.

Output Compliance and Load Resistance Equation: 7V minimum is required for each transmitter channel. A channel will drive up to 17V to a load with a 24V loop supply and 20mA of loop current (800Ω), assuming negligible line drop.

V _{supply} Volts	Max R _{load} w/21mA and No IR Line Drop
8V	47Ω
10V	143Ω
12V	238Ω
18V	524Ω
24V	810Ω
32V	1190Ω

USB Interface

IMPORTANT – USB Isolation is recommended: Inputs of this transmitter may connect to grounded or ungrounded signals. The input 1 circuit ground is connected in common to the USB power/signal/shield ground, which will in-turn connect to earth ground at the USB port of most Personal Computers without using an isolator. Failure to connect USB without isolation would connect the 1.25V input 1 bias supply to input ground if the sensor is also earth grounded, interfering with operation of input 1 and resulting in an output 1 shift. For this reason, USB isolation is strongly recommended when connecting to a PC. Otherwise, without USB isolation and when connected to a grounded input 1 sensor, a battery powered laptop could be used to connect to the unit, as the laptop does not normally connect to earth ground.

Enclosure & Physical

The unit has a general purpose plastic enclosure designed to mount on 35mm “T-type” DIN rail.

LED Indicators

DT units include a USB socket for temporary connection to a PC or laptop for set up and reconfiguration (or optionally to a USB-OTG cable connected to an Android smartphone or tablet). USB isolation is required when connected to a grounded input sensor or driver at input 1 (see note below). During reconfiguration and calibration, the transmitter receives power from both the USB port and the output loop. Both power sources must be present to calibrate the unit.

Data Rate: USB v1.1 full speed only, at 12Mbps. Up to 32K commands per second. USB 2.0 compatible.

Transient Protection: Adds transient voltage protection on USB power & data lines.

Inrush Current Limiting: Includes series inrush current limiting at USB power.

Cable Length/Connection Distance: 5.0meters maximum.

Driver: No special drivers required. Uses the built-in USB Human Interface Device (HID) drivers of the Windows Operating System (Windows XP or later versions only).

USB Connector: 5-pin, Mini USB B-type socket, HiRose UX60SC-MB-5S8(80).

PIN	DEFINITION
1	+5V Power (Includes Inrush Current Limiting)
2	Differential Data (+)
3	Differential Data (-)
4	NC – Not Connected
5 ¹	Power Ground (Connects to Signal Ground via ferrite bead)
SHLD ¹	Signal Ground (Connects directly to Signal Ground)

¹**Note:** Most Host Personal Computers (except battery powered laptops) will connect earth ground to the USB shield and signal ground.



CAUTION: Do not attempt to connect USB in a hazardous environment. Transmitter should be set up and configured in a safe environment only.

Dimensions: Width = 17.5mm (0.69 inches), Length = 114.5mm (4.51 inches), Depth = 99.0mm (3.90 inches). Refer to Mechanical Dimensions drawing.

I/O Connectors: Removable plug-in type terminal blocks rated for 12A/250V; AWG #26-12 (TB4, TB6) and AWG #14-30 (TB1, TB3), stranded or solid copper wire.

Program Connector: USB Mini B-type, 5-pin. See USB Interface.

Case Material: Self-extinguishing polyamide, UL94 V-0 rated, color light gray. General purpose NEMA Type 1 enclosure.

Circuit Board: Military grade fire-retardant epoxy glass per IPC-4101/98.

DIN-Rail Mounting: Unit is normally mounted to 35mm, T-type DIN rails. Refer to the DIN Rail Mounting & Removal section for more details.

Shipping Weight: 0.5 pounds (0.22 Kg) packed.

Red Output Fault LED Indicators (Each Output, FLT1 & FLT2) - Red FLT LED per output loop. Blinking red continuously indicates the corresponding output load resistance is too high to modulate loop current accurately, or the loop voltage level is too low to drive the loop resistance at the desired current level. OFF is normal, blinks for fault, or blinks once if the loop power is lost or the loop is opened.

Environmental

These limits represent the minimum requirements of the applicable standard, but this product has typically been tested to comply with higher standards in some cases.

Operating Temperature: -40°C to +80°C (-40°F to +176°F). It is recommended this unit be mounted upright on a DIN rail, allowing free air to flow into the bottom vent, pass through the unit and out the top vent.

Storage Temperature: -40°C to +85°C (-40°F to +185°F).

Relative Humidity: 5 to 95%, non-condensing.

Altitude: Up to 2000 meters.

Isolation: Input 1/USB, Input 2, Output 1, and Output 2 circuits are each isolated from each other for common-mode voltages up to 250VAC, or 354V DC off DC power ground, on a continuous basis (will withstand 1500VAC dielectric strength test for one minute without breakdown). Complies with test requirements of UL 61010C-1 First Edition, August 9, 2002 “UL Standard for Safety for Process Control Equipment” for the voltage rating specified.

Installation Category: Suitable for installation in a Pollution Degree 2 environment with an Installation Category (Over-voltage Category) II rating per IEC 1010-1 (1990).

Shock & Vibration Immunity: Random vibration: Designed to comply with VITA 47 Class V1. Shall withstand vibration from 5 to 100Hz. with Power Spectral Density (PSD) = 0.04g²/Hz, for 1 hour per axis. Testing shall be in accordance with MIL-STD-810, Method 514, Procedure 1. Mechanical shock: Designed to comply with VITA 47 Class OS1, 20g, 11ms half sine and terminal sawtooth shock pulses. 3 shock pulses in each direction along 3 axes (36 shocks, total). Testing shall be in accordance with MIL-STD-810, Method 516, Procedure 1.

Electromagnetic Compatibility (EMC)

Minimum Immunity per BS EN 61000-6-1:

- 1) Electrostatic Discharge Immunity (ESD), per IEC 61000-4-2.
- 2) Radiated Field Immunity (RFI), per IEC 61000-4-3.
- 3) Electrical Fast Transient Immunity (EFT), per IEC 61000-4-4.
- 4) Surge Immunity, per IEC 61000-4-5.
- 5) Conducted RF Immunity (CRFI), per IEC 61000-4-6.

This is a Class B Product with Emissions per BS EN 61000-6-3:

- 1) Enclosure Port, per CISPR 16.
- 2) Low Voltage AC Mains Port, per CISPR 14, 16.

Reliability Prediction

Reliability Prediction

MTBF (Mean Time Between Failure): MTBF in hours using MIL-HDBK-217F, FN2. *Per MIL-HDBK-217, Ground Benign, Controlled, G_BG_c*

Temperature	MTBF (Hours)	MTBF (Years)	Failure Rate (FIT ¹)
25°C	1,177,353 hrs	134.4 years	849.4
40°C	783,595 hrs	89.5 years	1,276.2

¹Note: FIT is Failures in 10⁹ hours.

Agency Approvals

Electromagnetic Compatibility (EMC): CE marked, per EMC Directive 2014/30/EU.

FCC Conformity: This device complies with Part 15, Class B of the FCC rules.

Safety Approvals: cULus Listed Class I, Division 2, Groups A, B, C, D Hazardous Location or Nonhazardous Locations only. These devices are open-type devices that are to be installed in an enclosure suitable for the environment. Consult Factory.

ATEX/IECEX Certified: ATEX/IECEX Certified for Explosive Atmospheres per ATEX Directive 2014/34/EU which complies with standards EN IEC 60079-0:2018, EN IEC 60079-7:2015 +A1:2018, IEC60079-0 Edition 7, and IEC 60079-7 Edition 5.1.

 II 3 G Ex ec IIC T4 Gc -40°C ≤ Ta ≤ +80°C
UL 20 ATEX 2416X IECEX UL 20.0088X
X = Special Conditions

- 1) The equipment shall only be used in an area of not more than pollution degree 2, as defined in EN/IEC 60664-1.
- 2) The equipment shall be installed in an enclosure that provides a degree of protection not less than IP 54 and only accessible with the use of a tool in accordance with EN/IEC 60079-0.
- 3) Transient protection should be provided and set to a level not exceeding 140% of the peak rated voltage value at the supply terminals to the equipment.

Configuration Controls

Software Configuration Only via USB/Windows or USB-OTG/Android & Agility

This transmitter drives analog output currents in two isolated 2-wire current loops proportional to corresponding sensor inputs based on a differential voltage measurement across the resistance sensors wired to TB1 (channel 1) or TB3 (channel 2). No switches or potentiometers are used to make adjustment to this transmitter. Its behavior as an isolated signal amplifier/transducer is determined via programmed variables set using a temporary USB connection to a host computer or laptop running a Windows-compatible configuration software program specific to the transmitter model, or a wired USB-OTG connection to an Android smartphone or tablet running Agility. The USB software or Agility app provides the framework for digital control of all configuration and calibration parameters, which are stored in non-volatile memory of the unit.

LED Indicators, Red FLT1 & FLT2

One Red FLT LED per output current loop. Blinking red continuously indicates the corresponding output load resistance is too high to drive its current accurately, or the loop voltage level is too low to drive the loop resistance at the desired current level. OFF is normal and LED will blink once if the loop power is lost or the loop is opened.

Refer to Operation Step-By-Step in the Technical Reference section of this manual for detailed information on available software control of this model.

REVISION HISTORY

The following table shows the revision history for this document:

Release Date	Version	EGR/DOC	Description of Revision
14-DEC-2018	A	BC/MJO	Initial Release Version "A".
16 JUN 2020	B	BC/MJO	MTBF information and EMC Directive updated.
15 SEP 2020	C	CAP/ARP	Added cULus, ATEX, IECEx, and FCC approvals.
28 JAN 2022	D	CAP/AMM	Added Altitude: Up to 2000 meters (Environmental Section)
11-OCT-2022	E	BC	Removed remnant reference to current/voltage inputs.