

Block Diagram

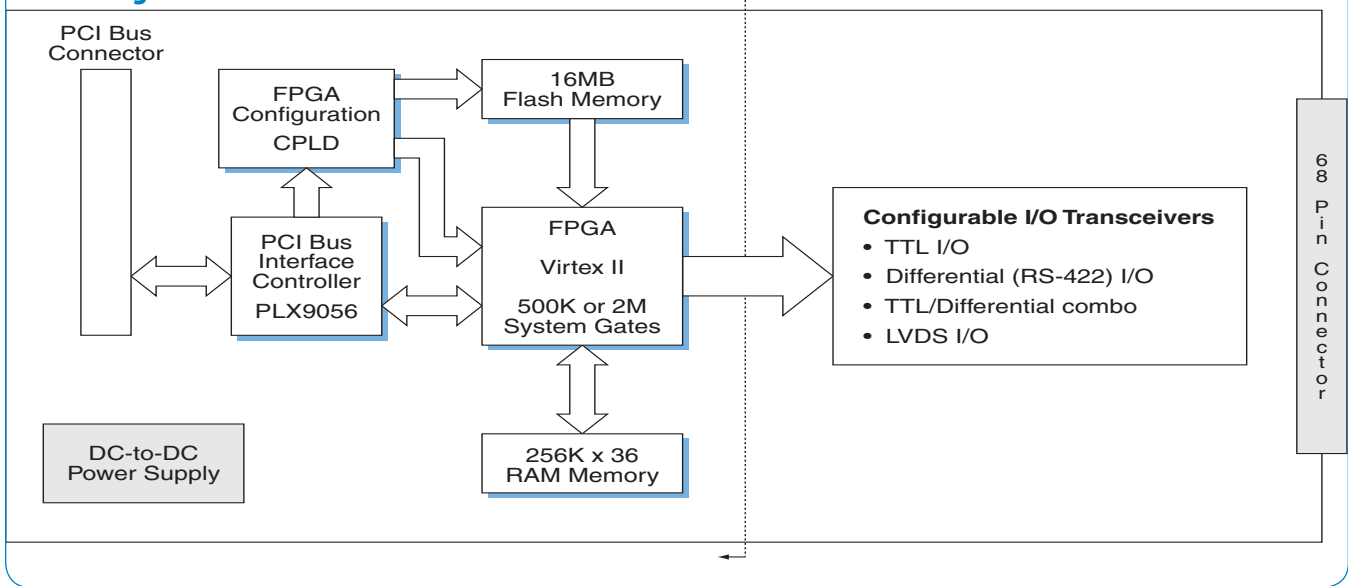

Engineering Design Kit

This kit provides you with the basic information required to develop a custom FPGA program for download to the Xilinx FPGA. Utilities help you load VHDL into the FPGA, and to establish DMA transfers between the FPGA and the CPU. It is also recommended that users should be familiar with Xilinx development tools.

Acromag's Engineering Design Kit includes:

- Parts list and location
- Schematics
- Compiled FPGA file
- Example VHDL code provided as selectable blocks of code

Local Bus – example interface between PLX PCI9056 and FPGA

SRAM – example code for read and write transfers to SRAM

Interrupts – examples of change-of-state monitoring and interrupts to the PCI bus

Field I/O – examples of direction control and I/O read/write capability

Pin definitions – configuration file containing definition of all user I/O pins communicating with the FPGA