



**Series IP501 Industrial I/O Pack
Quad EIA/TIA-422B Communication Module**

USER'S MANUAL

ACROMAG INCORPORATED
30765 South Wixom Road
P.O. BOX 437
Wixom, MI 48393-7037 U.S.A.
Tel: (248) 624-1541
Fax: (248) 624-9234

Copyright 1995, Acromag, Inc., Printed in the USA.
Data and specifications are subject to change without notice.

8500-541-G02H003

The information contained in this manual is subject to change without notice. Acromag, Inc. makes no warranty of any kind with regard to this material, including, but not limited to, the implied warranties of merchantability and fitness for a particular purpose. Further, Acromag, Inc. assumes no responsibility for any errors that may appear in this manual and makes no commitment to update, or keep current, the information contained in this manual. No part of this manual may be copied or reproduced in any form, without the prior written consent of Acromag, Inc.

Table of Contents	Page
1.0 GENERAL INFORMATION.....	2
KEY IP501 FEATURES.....	2
INDUSTRIAL I/O PACK INTERFACE FEATURES.....	3
SIGNAL INTERFACE PRODUCTS.....	3
INDUSTRIAL I/O PACK SOFTWARE LIBRARY.....	3
2.0 PREPARATION FOR USE.....	3
UNPACKING AND INSPECTION.....	3
CARD CAGE CONSIDERATIONS.....	4
BOARD CONFIGURATION.....	4
CONNECTORS.....	4
IP Field I/O Connector (P2).....	4
Noise and Grounding Considerations.....	5
IP Logic Interface Connector (P1).....	5
3.0 PROGRAMMING INFORMATION.....	6
ADDRESS MAPS.....	6
IP Communication & Configuration Registers.....	8
IP Identification PROM.....	14
THE EFFECT OF RESET.....	15
IP501 PROGRAMMING.....	15
FIFO Polled Mode.....	16
FIFO Interrupt Mode.....	16
Loopback Mode Operation.....	17
Interrupt Generation.....	17
Software Flow Control.....	17
Hardware Flow Control.....	18
Programming Example.....	18
4.0 THEORY OF OPERATION.....	19
EIA/TIA-422B SERIAL INTERFACE.....	19
IP501 OPERATION.....	20
LOGIC/POWER INTERFACE.....	21
5.0 SERVICE AND REPAIR.....	21
SERVICE AND REPAIR ASSISTANCE.....	21
PRELIMINARY SERVICE PROCEDURE.....	21
6.0 SPECIFICATIONS.....	21
GENERAL SPECIFICATIONS.....	21
EIA/TIA-422B PORTS.....	22
DRIVERS/RECEIVERS.....	22
INDUSTRIAL I/O PACK COMPLIANCE.....	22
APPENDIX.....	23
CABLE: MODEL 5025-550. & 5025-551.....	23
CABLE: MODEL 5029-943.....	23
TERMINATION PANEL: MODEL 5025-552.....	23
TRANSITION MODULE: MODEL TRANS-GP.....	24
DRAWINGS.....	Page
4501-434 IP MECHANICAL ASSEMBLY.....	25
4501-552 IP501 COMMUNICATION CONNECTIONS... ..	25
4501-554 IP501 INTERFACE DIAGRAM.....	26
4501-555 IP501 TERM/BIAS RESISTOR LOCATION....	27
4501-553 IP501 BLOCK DIAGRAM.....	28
4501-570 RS-422 INTERFACE LEVELS.....	29
4501-462 CABLE 5025-550 (NON-SHIELDED).....	30
4501-463 CABLE 5025-551 (SHIELDED).....	30
4501-464 TERMINATION PANEL 5025-552.....	31
4501-465 TRANSITION MODULE TRANS-GP.....	31

IMPORTANT SAFETY CONSIDERATIONS

It is very important for the user to consider the possible adverse effects of power, wiring, component, sensor, or software failures in designing any type of control or monitoring system. This is especially important where economic property loss or human life is involved. It is important that the user employ satisfactory overall system design. It is agreed between the Buyer and Acromag, that this is the Buyer's responsibility.

1.0 GENERAL INFORMATION

The Industrial I/O Pack (IP) Series IP501 module provides four EIA/TIA-422B serial communication ports for interfacing to the VMEbus or ISAbus, according to your carrier board. For half-duplex EIA-485 applications, the model IP502 is recommended, but the model IP501 can be used to implement an EIA-485 interface operating in full-duplex. Full-duplex data paths for Transmit (Tx), Receive (Rx), and the Request-to-Send (RTS) and Clear-to-Send (CTS) handshake lines are included. Four units may be mounted on a carrier board to provide up to 16 asynchronous serial ports per system slot.

The transmit and receive paths of each channel on IP501-16 units include generous 16-byte FIFO buffers to minimize CPU interaction. Model IP501-64 units utilize 64-byte FIFO buffers and include software flow controls. Full-duplex EIA/TIA-422B and EIA-485 DB-9 signal support for the common RTS and CTS handshake lines is included. Character size, stop bits, parity, and baud rate are software configurable. Prioritized interrupt generation is also supported for transmit, receive, line-status, and data set conditions. The IP501 utilizes state of the art Surface-Mounted Technology (SMT) to achieve its wide functionality and is an ideal choice for a wide range of industrial communication interface applications that require a highly reliable, high-performance interface at a low cost. For isolated interface requirements, refer to the Acromag Model IP511.

KEY IP501 FEATURES

- **High Density** - Provides programmable control of four EIA/TIA-422B serial ports. Four units mounted on a carrier board provide 16 serial channels in a single VMEbus or ISAbus (PC/AT) system slot.
- **Large FIFO Buffers** - The transmit and receive channels of each serial port provide generous 16-character (IP501-16), or 64-character (IP501-64) data buffering. This gives the host CPU additional time to process other applications and reduces CPU interactions and interrupts.
- **Programmable Character Size** - Each serial port is software programmable for 5, 6, 7, or 8 bit character sizes.
- **Programmable Stop Bits** - Each serial port allows 1, 1-1/2, or 2 stop-bits to be added to, or deleted from, the serial data stream.
- **Programmable Parity Generation & Detection** - Even, Odd, or No Parity generation and detection is supported.
- **Line-Break Generation & Detection** - provision for sending and detecting the line break character is provided.
- **False Start Bit Detection** - Prevents the receiver from assembling false data characters due to low-going noise spikes on the Rx/D input line.

- **Programmable Baud Rate** - The internal baud rate generator allows the 8MHz clock to be divided by any divisor between 1 and $2^{(16-1)}$, providing support for any bit rate up to 512Kbps.
- **Interrupt Support** - Individually controlled transmit, receive, line status, data set, & flow control (IP501-64) interrupts may be generated and unique interrupt vectors assigned to each port. Interrupts use a priority shifting scheme based on the last interrupt serviced, preventing the continuous interrupts of one port from blocking the interrupts of another port.
- **Flow Control** - The IP501-64 includes support for software and hardware flow control for more efficient data transfer.
- **Socketed Termination and Bias Resistors** - The network termination and bias resistors are installed in sockets on the board and may be easily inserted or removed where required.
- **Handshake/Modem Control Signals** - Each serial channel includes a modem-control and modem-status register that provides handshake support for RTS & CTS.
- **Internal Diagnostic Capabilities** - Loopback controls for communication link fault isolation are included. Break, parity, overrun, and framing error simulation is also possible.
- **Failsafe Receivers** - The receivers employed in this model include a fail-safe feature which guarantees a high output state when the inputs are left open or floating.
- **Extended Temperature Performance Option** - Model IP501-16E units support operation from -40°C to $+85^{\circ}\text{C}$.
- **Industry Standard 16550 Family UART w/16C450 Mode** - The UART of this device is a member of the industry standard 16550 family of UART's and remains software compatible. Additionally, this device can operate in a 16C450 UART family software compatible mode. The transmit and receive channels are double-buffered in this mode. Hold and shift registers eliminate the need for precise synchronization between the host CPU and the serial data.

INDUSTRIAL I/O PACK INTERFACE FEATURES

- **High density** - Single-size, industry standard, IP module footprint. Four units mounted on a carrier board provide up to 16 serial ports in a single system slot. Both VMEbus and ISAbus (PC/AT) carriers are supported.
- **Local ID** - Each IP module has its own 8-bit ID PROM which is accessed via data transfers in the "ID Read" space.
- **8-bit I/O** - Port register Read/Write is performed through 8-bit data transfer cycles in the IP module I/O space.
- **High Speed** - Access times for all data transfer cycles are described in terms of "wait" states - 2 wait states are required for reading and writing channel data and for interrupt select cycles, 1 wait state for reading the ID PROM (see the Specifications section for detailed information).

SIGNAL INTERFACE PRODUCTS

(See Appendix for more information on compatible products)

This IP module will mate directly to any industry standard IP carrier board (including Acromag AVME9630/9660 3U/6U non-intelligent VMEbus carrier boards). Additionally, ISAbus (PC/AT) carrier boards are supported (see Acromag Model APC8600). A wide range of other Acromag IP modules are also available to serve your signal conditioning and interface needs.

Note: Since all connections to field signals are made through the carrier board which passes them to the individual IP modules, you should consult the documentation of your carrier board to ensure compatibility with the following interface products.

Cables:

Model 5025-551-X (Shielded Cable), or Model 5025-550-X (Non-Shielded Cable): A Flat 50-pin cable with female connectors at both ends for connecting AVME9630/9660, APC8610, or other compatible carrier boards, to Model 5025-552 termination panels. The unshielded cable is recommended for digital I/O, while the shielded cable is recommended for optimum performance with precision analog I/O applications. The "-X" suffix of the model is used to specify the required length in feet.

Model 5029-943 IP500 Serial Communication Cable: A 5 foot long, flat 50-pin cable with a female connector on one end (for connection to AVME9630/9660 or other compatible carrier boards) and four DE-9P connectors (serial ports) on the other end. Also used for interface with Acromag Model IP501(RS-422) & IP502 (RS-485) serial communication modules.

Termination Panels:

Model 5025-552: A DIN-rail mountable panel that provides 50 screw terminals for universal field I/O termination. Connects to Acromag AVME9630/9660, APC8610, or other compatible carrier boards, via flat 50-pin ribbon cable (Model 5025-550-X or 5025-551-X).

Transition Module:

Model TRANS-GP: This module repeats field I/O connections of IP modules A through D for rear exit from a VMEbus card cage. It is available for use in card cages which provide rear exit for I/O connections via transition modules (transition modules can only be used in card cages specifically designed for them). It is a double-height (6U), single-slot module with front panel hardware adhering to the VMEbus mechanical dimensions, except for shorter printed circuit board depth. It connects to Acromag Termination Panel 5025-552 from the rear of the card cage, and to AVME9630/9660 boards within the card cage, via flat 50-pin ribbon cable (cable Model 5025-550 or 5025-551).

INDUSTRIAL I/O PACK SOFTWARE LIBRARY

Acromag provides an Industrial I/O Pack Software Library diskette (Model IPSW-LIB-M03, MSDOS format) to simplify communication with the board. Example software functions are provided for both ISAbus (PC/AT) and VMEbus applications. All functions are written in the "C" programming language and can be linked to your application. For more details, refer to the "README.TXT" file in the root directory on the diskette and the "INFO501.TXT" file in the appropriate "IP501" subdirectory off of "VMEIP" or "PCIP", according to your carrier.

2.0 PREPARATION FOR USE

UNPACKING AND INSPECTION

Upon receipt of this product, inspect the shipping carton for evidence of mishandling during transit. If the shipping carton is badly damaged or water stained, request that the carrier's agent be present when the carton is opened. If the carrier's agent is not present when the carton is opened and the contents of the carton are damaged, keep the carton and packing material for the agent's inspection.

For repairs to a product damaged in shipment, refer to the Acromag Service Policy to obtain return instructions. It is suggested that salvageable shipping cartons and packing material be saved for future use in the event the product must be shipped.



This board is physically protected with packing material and electrically protected with an anti-static bag during shipment. However, it is recommended that the board be visually inspected for evidence of mishandling prior to applying power.

The board utilizes static sensitive components and should only be handled at a static-safe workstation.

CARD CAGE CONSIDERATIONS

Refer to the specifications for loading and power requirements. Be sure that the system power supplies are able to accommodate the power requirements of the carrier board, plus the installed IP modules, within the voltage tolerances specified.

IMPORTANT: Adequate air circulation must be provided to prevent a temperature rise above the maximum operating temperature.

The dense packing of the IP modules to the carrier board restricts air flow within the card cage and is cause for concern. Adequate air circulation must be provided to prevent a temperature rise above the maximum operating temperature and to prolong the life of the electronics. If the installation is in an industrial environment and the board is exposed to environmental air, careful consideration should be given to air-filtering.

BOARD CONFIGURATION

Remove power from the board when installing IP modules, cables, termination panels, and field wiring. Refer to Mechanical Assembly Drawing 4501-434 and your IP module documentation for configuration and assembly instructions. Model IP501 communication boards have no hardware jumpers or switches to configure. However, network termination and bias resistor SIPS are installed in sockets on the board and can be easily removed where required (refer to Drawing 4501-554 & 4501-555).

IMPORTANT: The IP501 comes with network termination (120Ω) and bias (560Ω) resistor SIP's installed in sockets on the board. You need to consider your network application carefully, and remove some resistors where appropriate. Termination resistors should only be installed at the ends of a network, and if the transmitters are always enabled, then you should remove the termination resistors from the transmitter side. Likewise, a network channel only needs one set of bias resistors, usually on the driving end. You should also remove redundant bias resistors where appropriate. Failure to remove termination and bias resistors where required will significantly increase current draw, and in some cases, may affect performance. Refer to Drawing 4501-554 & 4501-555 for instructions.

CONNECTORS

IP Field I/O Connector (P2)

P2 provides the field I/O interface connections for mating IP modules to the carrier board. P2 is a 50-pin female receptacle header (AMP 173279-3 or equivalent) which mates to the male connector of the carrier board (AMP 173280-3 or equivalent). This provides excellent connection integrity and utilizes gold-plating in the mating area. Threaded metric M2 screws and spacers are supplied with the module to provide additional stability for harsh environments (see Mechanical Assembly Drawing 4501-434). The field and logic side connectors are keyed to avoid incorrect assembly. P2 pin assignments are unique to each IP model (see Table 2.1) and normally correspond to the pin numbers of the field I/O interface connector on the carrier board (you should verify this for your carrier board).

Table 2.1: IP501 Field I/O Pin Connections (P2)

Pin Description	Number	Pin Description	Number
COMMON	1	COMMON	26
CTS+ _A*	2	CTS+ _C*	27
TXD+ _A	3	TXD+ _C	28
CTS- _A*	4	CTS- _C*	29
TXD- _A	5	TXD- _C	30
RTS- _A*	6	RTS- _C*	31
RXD- _A	7	RXD- _C	32
RTS+ _A*	8	RTS+ _C*	33
RXD+ _A	9	RXD+ _C	34
COMMON	10	COMMON	35
CTS+ _B*	11	CTS+ _D*	36
TXD+ _B	12	TXD+ _D	37
CTS- _B*	13	CTS- _D*	38
TXD- _B	14	TXD- _D	39
RTS- _B*	15	RTS- _D*	40
RXD- _B	16	RXD- _D	41
RTS+ _B*	17	RTS+ _D*	42
RXD+ _B	18	RXD+ _D	43
COMMON	19	COMMON	44
COMMON	20	COMMON	45
COMMON	21	COMMON	46
COMMON	22	COMMON	47
COMMON	23	COMMON	48
COMMON	24	COMMON	49
COMMON	25	COMMON	50

An Asterisk (*) is used to indicate an active-low signal.

Note that the pin-wire assignments are arranged such that IDC D-SUB ribbon cable connectors can be conveniently attached to provide serial port A (pins 1-9), serial port B (pins 10-18), serial port C (pins 26-34), & serial port D (pins 35-43) connectivity. Plus (+) and minus (-) following the signal name indicate differential signal polarity. In Table 2.1, a suffix of "_A", "_B", "_C", or "_D" is appended to each pin label to denote its port association. A brief description of each of the serial port signals at P2 is included below. A complete functional description of the P2 pin functions is included in Section 4.0 (Theory Of Operation). Be careful not to confuse the A-D port designations of the IP module with the IP carrier board A-D slot designations.

P2 Pin Signal Descriptions

SIGNAL ±	DESCRIPTION
RxD_A RxD_B RxD_C RxD_D	Receive Data Line Input - This is the receive data input line. During Loopback Mode, the RxD input is disabled from the external connection and connected to the TxD output internally. On this model, the DTR bit of the Modem Control Register is used to enable the RxD & CTS receivers.
TxD_A TxD_B TxD_C TxD_D	Transmit Data Line Output - This is the transmit output data line. In the idle state, this signal line is held in the mark (logic 1) state. During Loopback Mode, the TxD output is internally connected to the RxD input.
RTS_A* RTS_B* RTS_C* RTS_D*	Request-to-Send Output - The RTS output is turned on to tell the modem it is ready to send data. This signal can be set low (active) by writing a 1 to the Modem Control Register. Normally, this signal has no effect on the transmit or receive operation, unless hardware flow control is enabled. Likewise, on this model the RTS signal is also used to enable the transmitters of the channel (TxD & RTS) when the corresponding Transmit Enable Always Register (TEA) bit is set to 0.
CTS_A* CTS_B* CTS_C* CTS_D*	Clear-to-Send Input - Turned on by the receiving device to indicate it is ready to receive data. The input status of this signal can be read via bit 4 of the Modem Status Register. CTS has no effect on the transmit or receive operation, unless hardware flow control is enabled. On this model, the DTR bit of the Modem Control Register is used to enable the CTS & RxD receiver.

Note that not all UART signal paths are used by this model and their corresponding UART pins are tied high (+5V). This includes, RI (Ring Indicator), DSR (Data Set Ready), and DCD (Data Carrier Detect). In addition, the UART DTR (Data Terminal Ready) signal path is used to control the receiver enables for the port. The RTS signal is used in combination with the TEA (Transmit Enable Always) register to control the transmitter enables for the port.

Noise and Grounding Considerations

The serial channels of this module are non-isolated and share a common signal ground connection. Further, the IP501 is non-isolated between the logic and field I/O grounds since signal common is electrically connected to the IP module ground. Consequently, the field interface connections are not isolated from the carrier board and backplane. Care should be taken in designing installations without isolation to avoid noise pickup and ground loops caused by multiple ground connections.

The signal ground connection at the communication ports are common to the IP interface ground, which is typically common to safety (chassis) ground when mounted on a carrier board and inserted in a backplane. As such, be careful not to attach signal ground to safety ground via any device connected to these ports, or a ground loop will be produced, and this may adversely affect operation.

The communication cabling of the P2 interface carries digital data at a high transfer rate. For best performance, increased signal integrity, and safety reasons, you should isolate these connections away from power and other wiring to avoid noise-coupling and crosstalk interference. EIA/TIA-422B communication distances are generally limited to less than 4000 feet. Always keep interface cabling and ground wiring as short as possible for best performance. Please refer to Drawing 4501-552 for example connections and recommended grounding practices.

IP Logic Interface Connector (P1)

P1 of the IP module provides the logic interface to the mating connector on the carrier board. This connector is a 50-pin female receptacle header (AMP 173279-3 or equivalent) which mates to the male connector of the carrier board (AMP 173280-3 or equivalent). This provides excellent connection integrity and utilizes gold-plating in the mating area. Threaded metric M2 screws and spacers are supplied with the IP module to provide additional stability for harsh environments (see Drawing 4501-434 for assembly details). Field and logic side connectors are keyed to avoid incorrect assembly. The pin assignments of P1 are standard for all IP modules according to the Industrial I/O Pack Specification (see Table 2.2).

Table 2.2: Standard Logic Interface Connections (P1)

Pin Description	Number	Pin Description	Number
GND	1	GND	26
CLK	2	+5V	27
Reset*	3	R/W*	28
D00	4	IDSEL*	29
D01	5	<i>DMAReq0*</i>	30
D02	6	MEMSEL*	31
D03	7	<i>DMAReq1*</i>	32
D04	8	IntSel*	33
D05	9	<i>DMAck0*</i>	34
D06	10	IOSEL*	35
D07	11	<i>RESERVED</i>	36
<i>D08</i>	12	A1	37
<i>D09</i>	13	<i>DMAEnd*</i>	38
<i>D10</i>	14	A2	39
<i>D11</i>	15	<i>ERROR*</i>	40
<i>D12</i>	16	A3	41
<i>D13</i>	17	INTRReq0*	42
<i>D14</i>	18	A4	43
<i>D15</i>	19	<i>INTRReq1*</i>	44
BS0*	20	A5	45
<i>BS1*</i>	21	<i>STROBE*</i>	46
<i>-12V</i>	22	A6	47
<i>+12V</i>	23	ACK*	48
+5V	24	<i>RESERVED</i>	49
GND	25	GND	50

An Asterisk (*) is used to indicate an active-low signal.
BOLD ITALIC Logic Lines are NOT USED by this IP Model.

3.0 PROGRAMMING INFORMATION

ADDRESS MAPS

This board is addressable in the Industrial Pack I/O space to control the interface configuration, data transfer, and steering logic of four EIA/TIA-422B serial ports. As such, three types of information are stored in the I/O space: control, status, and data. These registers are listed below along with their mnemonics used throughout this manual.

SERIAL DATA REGISTERS (Per Serial Port):	
RBR	Receive Buffer Register
THR	Transmitter Holding Register
SERIAL STATUS REGISTERS (Per Serial Port):	
LSR	Line Status Register
MSR	Modem Status Register
SERIAL CONTROL REGISTERS (Per Serial Port):	
LCR	Line Control Register
FCR	FIFO Control Register
MCR	Modem Control Register
DLL	Divisor Latch LSB
DLM	Divisor Latch MSB
IER	Interrupt Enable Register
SCR	Scratchpad/Interrupt Vector Register
TEA	Transmit Enable Always Register
EFR	Enhanced Feature Register (IP501-64 Models)
XON-1	XON-1 Word (IP501-64 Models Only)
XON-2	XON-2 Word (IP501-64 Models Only)
XOFF-1	XOFF-1 Word (IP501-64 Models Only)
XOFF-2	XOFF-2 Word (IP501-64 Models Only)

Shaded register entries apply to Model IP501-64 only and are accessible only after writing "BF" to the Line Control Register (LCR).

The I/O space may be as large as 64, 16-bit words (128 bytes) using address lines A1..A6, but the IP501 uses only a portion of this space. The I/O space address map for the IP501 is shown in Table 3.1. Note the base address for the IP module I/O space (see your carrier board instructions) must be added to the addresses shown to properly access the I/O space. All accesses are performed on an 8-bit word basis (D0..D7).

This manual is presented using the "Big Endian" byte ordering format. Big Endian is the convention used in the Motorola 68000 microprocessor family and is the VMEbus convention. In Big Endian, the lower-order byte is stored at odd-byte addresses. Thus, byte accesses are done on odd address locations. The Intel x86 family of microprocessors use the opposite convention, or "Little Endian" byte ordering. Little Endian uses even-byte addresses to store the low-order byte. As such, use of this module on an ISAbus (PC/AT) carrier board will require the use of the even address locations to access the 8-bit data, while a VMEbus carrier will require the use of odd address locations.

Note that some functions share the same register address. For these items, the address lines are used along with the divisor latch access bit (bit 7 of the Line Control Register) and/or the read and write signals to determine the function required. The enhanced feature registers of Model IP501-64 are shaded in the table that follows and only accessible after writing "BF" to the Line Control Register (LCR).

Table 3.1: IP501 I/O Space Address (Hex) Memory Map

Base Addr+	MSB		LSB		LCR Bit7	Base Addr+
	D15	D08	D07	D00		
Serial Port A Registers:						
00	Not Driven ¹		READ - RBR Port A Receiver Buffer Register		0	01
00	Not Driven ¹		WRITE - THR Port A Transmitter Holding Register		0	01
00	Not Driven ¹		R/W - DLL Port A Divisor Latch LSB		1	01
02	Not Driven ¹		R/W - IER Port A Interrupt Enable Register		0	03
02	Not Driven ¹		R/W - DLM Port A Divisor Latch MSB		1	03
04	Not Driven ¹		R/W - EFR ⁴ Port A Enhanced Function Register ("64" models only)		1	05
08	Not Driven ¹		R/W- XON-1 Word Port A SW Flow Control ⁴		1	09
0A	Not Driven ¹		R/W- XON-2 Word Port A SW Flow Control ⁴		1	0B
0C	Not Driven ¹		R/W- XOFF-1 Word Port A SW Flow Control ⁴		1	0D
0E	Not Driven ¹		R/W- XOFF-2 Word Port A SW Flow Control ⁴		1	0F
Base Addr+	MSB		LSB		LCR Bit7	Base Addr+
	D15	D08	D07	D00		
04	Not Driven ¹		READ - IIR Port A Interrupt Identification Register			05
04	Not Driven ¹		WRITE - FCR Port A FIFO Control Register			05
06	Not Driven ¹		R/W - LCR Port A Line Control Register			07
08	Not Driven ¹		R/W - MCR Port A Modem Control Register			09
0A	Not Driven ¹		R/W - LSR Port A Line Status Register			0B
0C	Not Driven ¹		R/W - MSR Port A Modem Status Register			0D
0E	Not Driven ¹		R/W - SCR Port A Scratch Pad/Interrupt Vector Register			0F

Shaded register entries apply to Model IP501-64 units only and are accessible after writing "BF" to the Line Control Register (LCR).

Table 3.1: IP501 I/O Space Memory Map...continued

Serial Port B Registers:				
Base Addr+	MSB D15 D08	LSB D07 D00	LC R Bit7	Base Addr+
10	Not Driven ¹	READ - RBR Port B Receiver Buffer Register	0	11
10	Not Driven ¹	WRITE - THR Port B Transmitter Holding Register	0	11
10	Not Driven ¹	R/W - DLL Port B Divisor Latch LSB	1	11
12	Not Driven ¹	R/W - IER Port B Interrupt Enable Register	0	13
12	Not Driven ¹	R/W - DLM Port B Divisor Latch MSB	1	13
14	Not Driven ¹	R/W - EFR ⁴ Port B Enhanced Function Register ("64" models only)	1	15
18	Not Driven ¹	R/W- XON-1 Word Port B SW Flow Control ⁴	1	19
1A	Not Driven ¹	R/W- XON-2 Word Port B SW Flow Control ⁴	1	1B
1C	Not Driven ¹	R/W- XOFF-1 Word Port B SW Flow Control ⁴	1	1D
1E	Not Driven ¹	R/W- XOFF-2 Word Port B SW Flow Control ⁴	1	1F
Base Addr+	MSB D15 D08	LSB D07 D00		Base Addr+
14	Not Driven ¹	READ - IIR Port B Interrupt Identification Register		15
14	Not Driven ¹	WRITE - FCR Port B FIFO Control Register		15
16	Not Driven ¹	R/W - LCR Port B Line Control Register		17
18	Not Driven ¹	R/W - MCR Port B Modem Control Register		19
1A	Not Driven ¹	R/W - LSR Port B Line Status Register		1B
1C	Not Driven ¹	R/W - MSR Port B Modem Status Register		1D
1E	Not Driven ¹	R/W - SCR Port B Scratch Pad/Interrupt Vector Register		1F

Shaded register entries apply to Model IP501-64 units only and are accessible after writing "BF" to the Line Control Register (LCR).

Table 3.1: IP501 I/O Space Memory Map...continued

Serial Port C Registers:				
Base Addr+	MSB D15 D08	LSB D07 D00	LC R Bit7	Base Addr+
20	Not Driven ¹	READ - RBR Port C Receiver Buffer Register	0	21
20	Not Driven ¹	WRITE - THR Port C Transmitter Holding Register	0	21
20	Not Driven ¹	R/W - DLL Port C Divisor Latch LSB	1	21
22	Not Driven ¹	R/W - IER Port C Interrupt Enable Register	0	23
22	Not Driven ¹	R/W - DLM Port C Divisor Latch MSB	1	23
24	Not Driven ¹	R/W - EFR ⁴ Port C Enhanced Function Register ("64" models only)	1	25
28	Not Driven ¹	R/W- XON-1 Word Port C SW Flow Control ⁴	1	29
2A	Not Driven ¹	R/W- XON-2 Word Port C SW Flow Control ⁴	1	2B
2C	Not Driven ¹	R/W- XOFF-1 Word Port C SW Flow Control ⁴	1	2D
2E	Not Driven ¹	R/W- XOFF-2 Word Port C SW Flow Control ⁴	1	2F
Base Addr+	MSB D15 D08	LSB D07 D00		Base Addr+
24	Not Driven ¹	READ - IIR Port C Interrupt Identification Register		25
24	Not Driven ¹	WRITE - FCR Port C FIFO Control Register		25
26	Not Driven ¹	R/W - LCR Port C Line Control Register		27
28	Not Driven ¹	R/W - MCR Port C Modem Control Register		29
2A	Not Driven ¹	R/W - LSR Port C Line Status Register		2B
2C	Not Driven ¹	R/W - MSR Port C Modem Status Register		2D
2E	Not Driven ¹	R/W - SCR Port C Scratch Pad/Interrupt Vector Register		2F

Shaded register entries apply to Model IP501-64 units only and are accessible after writing "BF" to the Line Control Register (LCR).

Table 3.1: IP501 I/O Space Memory Map...continued

Serial Port D Registers:						
Base Addr+	MSB		LSB		Base Addr+	
	D15	D08	D07	D00		
					LC R Bit7	
30	Not Driven ¹		READ - RBR Port D Receiver Buffer Register		0	31
30	Not Driven ¹		WRITE - THR Port D Transmitter Holding Register		0	31
30	Not Driven ¹		R/W - DLL Port D Divisor Latch LSB		1	31
32	Not Driven ¹		R/W - IER Port D Interrupt Enable Register		0	33
32	Not Driven ¹		R/W - DLM Port D Divisor Latch MSB		1	33
34	Not Driven ¹		R/W - EFR ⁴ Port D Enhanced Function Register ("64" models only)		1	35
38	Not Driven ¹		R/W - XON-1 Word Port D SW Flow Control ⁴		1	39
3A	Not Driven ¹		R/W - XON-2 Word Port D SW Flow Control ⁴		1	3B
3C	Not Driven ¹		R/W - XOFF-1 Word Port D SW Flow Control ⁴		1	3D
3E	Not Driven ¹		R/W - XOFF-2 Word Port D SW Flow Control ⁴		1	3F
Base Addr+	MSB		LSB		Base Addr+	
	D15	D08	D07	D00		
34	Not Driven ¹		READ - IIR Port D Interrupt Identification Register			35
34	Not Driven ¹		WRITE - FCR Port D FIFO Control Register			35
36	Not Driven ¹		R/W - LCR Port D Line Control Register			37
38	Not Driven ¹		R/W - MCR Port D Modem Control Register			39
3A	Not Driven ¹		R/W - LSR Port D Line Status Register			3B
3C	Not Driven ¹		R/W - MSR Port D Modem Status Register			3D
3E	Not Driven ¹		R/W - SCR Port D Scratch Pad/ Interrupt Vector Register			3F
40	Not Driven ¹		R/W - TEA Transmit Enable Always Register			41
42 ↓ 7E	NOT USED ²					43 ↓ 7F

Shaded register entries apply to Model IP501-64 units only and are accessible after writing "BF" to the Line Control Register (LCR).

Notes (Table 3.1):

1. The upper 8 bits of these registers are not driven. Pullups on the carrier board data bus will cause these bits to always read high (1's).
2. The IP will not respond to addresses that are "Not Used".
3. All Reads and writes are 2 wait states (except ID PROM reads which are 1 wait state).
4. Shaded register entries apply only to the enhanced functionality of Model IP501-64 and can be ignored for Model IP501-16 units. These control registers are accessed only after writing "BF" to the Line Control Register (LCR).

This board operates in two different modes. In one mode, this device remains software compatible with the industry standard 16C450 family of UARTS and provides double-buffering of data registers. In the FIFO Mode (enabled via bit 0 of the FCR register), data registers are FIFO-buffered so that read and write operations can be performed while the UART is performing serial-to-parallel and parallel-to-serial conversions. Two FIFO modes are possible: FIFO Interrupt Mode and FIFO Polled Mode. Some registers operate differently between the available modes and this is noted in the following paragraphs.

RBR - Receiver Buffer Register, Ports A-D (READ Only)

The Receiver Buffer Register (RBR) is a serial port input data register that receives the input data from the receiver shift register and holds from 5 to 8 bits of data, as specified by the character size programmed in the Line Control Register (LCR bits 0 & 1). If less than 8 bits are transmitted, then data is right-justified to the LSB. If parity is used, then LCR bit 3 (parity enable) and LCR bit 4 (type of parity) are required. Status for the receiver is provided via the Line-Status Register (LSR). When a full character is received (including parity and stop bits), the data-received indication bit (bit 0) of the LSR is set to 1. The host CPU then reads the Receiver Buffer Register, which resets LSR bit 0 low. If the character is not read prior to a new character transfer between the receiver shift register and the receiver buffer register, the overrun-error status indication is set in LSR bit 1. If there is a parity error, the error is indicated in LSR bit 2. If a stop bit is not detected, a framing error indication is set in bit 3 of the LSR.

Serial asynchronous data is input to the receiver shift register via the receive data line (RxD). From the idle state, this line is monitored for a high-to-low transition (start bit). When the start bit is detected, a counter is reset and counts the 16x clock to 7-1/2 (which is the center of the start bit). The start bit is judged valid if RxD is still low at this point. This is known as false start-bit detection. By verifying the start bit in this manner, it helps to prevent the receiver from assembling an invalid data character due to a low-going noise spike on RxD. If the data on RxD is a symmetrical square wave, the center of the data cells will occur within ±3.125% of the actual center (providing an error margin of 46.875%). Thus, the start bit can begin as much as one 16x clock cycle prior to being detected.

Note that the receivers for the channel (RxD & CTS) are enabled by asserting the DTR signal via the Modem Control Register (MCR bit 0).

THR - Transmitter Holding Register, Ports A-D (WRITE Only)

The Transmitter Holding Register (THR) is a serial port output data register that holds from 5 to 8 bits of data, as specified by the character size programmed in the Line Control Register. If less than 8 bits are transmitted, then data is entered right-justified to the LSB. This data is framed as required, then shifted to the transmit data line (TxD). In the idle state, TxD is held high. In Loopback Mode, this data is looped back into the Receiver Buffer Register.

For this model, note that the transmitters for a channel (TxD & RTS) are enabled via the RTS asserted signal bit in the Modem Control Register when the corresponding Transmit Enable Always Register bit is set to 0.

DLL & DLM - Divisor Latch Registers, Ports A-D (R/W)

The Divisor Latch Registers form the divisor used by the internal baud-rate generator to divide the 8MHz system clock to produce an internal sampling clock suitable for synchronization to the desired baud rate. The output of the baud generator (RCLK) is sixteen times the baud rate. Two 8-bit divisor latch registers per port are used to store the divisors in 16-bit binary format. The DLL register stores the low-order byte of the divisor, DLM stores the high-order byte. These registers must be loaded during initialization.

Note that bit 7 of the LCR register must first be set high to access the divisor latch registers (DLL & DLM) during a read/write operation.

Upon loading either latch, a 16-bit baud counter is immediately loaded (this prevents long counts on initial load). The clock may be divided by any divisor from 1 to 2⁽¹⁶⁻¹⁾. The output frequency of the baud rate generator (RCLK) is 16x the data rate. The relationship between the output of the baud generator (RCLK), the baud rate, the divisor, and the 8MHz system clock can be summarized in the following equations:

$$\begin{aligned} \text{DIVISOR} &= \text{CLOCK FREQUENCY} \div [\text{BAUD RATE} \times 16]; \\ \text{RCLK} &= 16 \times \text{BAUD RATE}; \\ &= 16 \times [\text{CLOCK} \div (16 \times \text{DIVISOR})] = \text{CLOCK} \div \text{DIVISOR} \end{aligned}$$

The following table shows the correct divisor to use for generation of some standard baud rates (based on the 8MHz clock). Note that baud rates up to 512K may be configured. Provisions for installation of an external crystal has been provided on the circuit board (16MHz). With a 16MHz crystal, a 1Mbps baud rate is possible--you may contact Acromag Applications Engineering to explore options in this area.

With respect to this device, the baud rate may be considered equal to the number of bits transmitted per second (bps). The bit rate (bps), or baud rate, defines the bit time. This is the length of time a bit will be held on before the next bit is transmitted. A receiver and transmitter must be communicating at the same bit rate, or data will be garbled. A receiver is alerted to an incoming character by the start bit, which marks the beginning of the character. It then times the incoming signal, sampling each bit as near to the center of the bit time as possible.

Table 3.2: Baud Rate Divisors and Relative Error (8MHz Clk)

BAUD RATE DESIRED	DIVISOR (N) USED FOR 16x CLOCK		% ERROR DIFF BET DESIRED & ACTUAL
50	10000	2710H	0
75	6667	1A06H	0.005
110	4545	11C1H	0.010
134.5	3717	0E85H	0.013
150	3333	0D05H	0.010
300	1667	0683H	0.020
600	833	0341H	0.040
1200	417	01A1H	0.080
1800	277	0115H	0.080
2000	250	00FAH	0
2400	208	00D0H	0.160
3600	139	0086H	0.080
4800	104	0068H	0.160
7200	69	0045H	0.644
9600	52	0034H	0.160
19200	26	001AH	0.160
38400	13	000DH	0.160
56000	9	0009H	0.790
128000	4	0004H	2.344
256000	2	0002H	2.344
512000	1	0001H	2.400

To better understand the asynchronous timing used by this device, note that the receive data line (RxD) is monitored for a high-to-low transition (start bit). When the start bit is detected, a counter is reset and counts the 16x sampling clock to 7-1/2 (which is the center of the start bit). The receiver then counts from 0 to 15 to sample the next bit near its center, and so on, until a stop bit is detected, signaling the end of the data stream. Use of a sampling rate 16x the baud rate reduces the synchronization error that builds up in estimating the center of each successive bit following the start bit. As such, if the data on RxD is a symmetrical square wave, the center of each successive data cell will occur within ±3.125% of the actual center (this is 50% ÷ 16, providing an error margin of 46.875%). Thus, the start bit can begin as much as one 16x clock cycle prior to being detected.

EFR - Enhanced Function Register, Ports A-D (R/W) (Model IP501-64 Only)

The enhanced features of the Model IP501-64 can be enabled/disabled via this register. This register is also used to unlock access to programming the extended register functionality of IER bits 4-7, IIR bits 4-5, FCR bits 4-5, and MCR bits 5-7. It is also used to program hardware or software flow control. Note that bits 6 & 7 are used for hardware flow control.

Enhanced Function Register (EFR)

EFR BIT	FUNCTION
0-3	Allows combinations of software flow control to be programmed (see table below).
4	Enhanced Functions Enable bit. 0 = disable enhanced functions controlled via IER bits 4-7, IIR bits 4-5, FCR bits 4-5, and MCR bits 5-7 (Note that after reset, these bits are set to "0" to maintain compatibility with the 16C550 standard functionality mode). 1 = Enable all enhanced features. Allows IER bits 4-7, IIR bits 4-5, FCR bits 4-5, and MCR bits 5-7 to be modified. Then after modification, EFR bit 4 can be set to "0" to latch the contents, and prevent existing software from overwriting the enhanced functionality provided by these bits.
5	0 = Normal; 1 = Enable Special Character Detect. If enabled, the UART will compare the received data with the XOFF-2 data. Upon a correct match, the received data will be transferred to the FIFO and IIR bit 4 will be set to indicate the detection of the special character.
6	Auto-RTS* - Hardware RTS flow Control Enable 0 = Normal (RTS flow control disabled); 1 = Enable RTS* pin to go high (deasserted) when the receive FIFO has reached its programmed trigger level.
7	Auto-CTS* - Hardware CTS flow Control Enable 0 = Normal (CTS flow control disabled); 1 = Resume transmission when a low input signal (CTS* asserted) is detected on the CTS* pin.

Under software flow control, different conditions can be set to detect XON/XOFF characters in the data stream, or start/stop transmission. The following table lists all the possible conditions:

Software Flow Control Via EFR Bits 0-3

Bit3	Bit2	Bit1	Bit0	Tx/Rx Software Flow Controls
0	0	X	X	No Transmit Flow Control
1	0	X	X	Transmit XON1, XOFF1
0	1	X	X	Transmit XON2, XOFF2
1	1	X	X	Transmit XON1, XON2: XOFF1, XOFF2
X	X	0	0	No Receive Flow Control
X	X	1	0	Receiver Compares XON1,XOFF1
X	X	0	1	Receiver Compares XON2,XOFF2
1	0	1	1	Transmit XON1, XOFF1. Receiver Compares XON1 or XON2, XOFF1 or XOFF2.
0	1	1	1	Transmit XON2, XOFF2. Receiver Compares XON1 or XON2, XOFF1 or XOFF2.
1	1	1	1	Transmit XON1 & XON2: XOFF1 & XOFF2. Receiver Compares XON1 & XON2: XOFF1 & XOFF2.
0	0	1	1	No Transmit Flow Control. Receiver Compares XON1 & XON2: XOFF1 and XOFF2.

Note that access to this register is granted only after writing "BF" to the Line Control Register (LCR). EFR Bits 0-7 are set to 0 upon power-up or system reset.

**XON/XOFF-1,2 Registers, Ports A-D (R/W)
(Model IP501-64 Only)**

These registers hold the programmed XON and XOFF characters for software flow control. XON or XOFF characters may be 1 or 2 bytes long. The UART compares incoming data to these values and restarts (XON) or suspends (XOFF) data transmission when a match is detected. Note that access to these registers are granted only after writing "BF" to the Line Control Register (LCR). All XON/XOFF bits are set to 0 upon power-up or system reset. Refer to "Software Flow Control" later in this section for more information.

IER - Interrupt Enable Register, Ports A-D (R/W)

The Interrupt Enable Register is used to independently enable/disable the four possible serial channel interrupt sources that drive the INTREQ0* line (Ports A-D share this line). Interrupts are disabled by resetting the corresponding IER bit low (0), and enabled by setting the IER bit high (1). Disabling the interrupt system (IER bits 0-3 low) also inhibits the Interrupt Identification Register (IIR) and the interrupt request line (INTREQ0*). All other functions operate in their normal manner, including the setting of the Line Status Register (LSR) and the Modem Status Register (MSR).

Interrupt Enable Register

IER BIT	INTERRUPT ACTION
0	Received Data Available Interrupt Enable and Time-Out Interrupt (FIFO Mode) Enable
1	Transmitter Holding Register Empty Interrupt Enable
2	Receiver Line Status Interrupt Enable
3	Modem Status Interrupt Enable
4-7	Not Used - Set to Logic 0
MODEL IP501-64 ONLY	
4	0 = Disable Sleep Mode. 1 = Enable Sleep Mode - The UART will enter a "sleep" power-down mode and the clock/oscillator circuit is disabled. Any change of state on Rx, RI, CTS, DSR, and DCD will wake-up the UART (note that only the CTS* and RTS* handshake lines are implemented on this model). The UART will not lose the programmed bits when sleep mode is activated or deactivated. The UART will not enter sleep mode if any interrupt is pending.
5	0 = Disable the Received XOFF interrupt. 1 = Enable the Received XOFF interrupt. The UART issues an interrupt when XOFF characters are received and correctly matched against the pre-programmed XOFF-1,2 words.
6	0 = Disable the RTS* interrupt 1 = Enable the generation of an RTS* interrupt when RTS* changes from a low to high state.
7	0 = Disable the CTS interrupt 1 = Enable the generation of the CTS interrupt when CTS changes from a low to high state.

Shaded Entries apply to Model IP501-64 functionality only.

A power-up or system reset sets all IER bits to 0 (bits 0-3 forced low, bits 4-7 permanently low). For IP501-64 models, program access to the enhanced functionality provided via bits 4-7 of this register is gained through setting EFR bit 4. Programmed values for bits 4-7 cannot be overwritten via existing software if EFR bit 4 is clear (these values are latched when EFR bit 4 is cleared).

IIR - Interrupt Identification Register, Ports A-D (READ Only)

The Interrupt Identification Register (IIR) is used to indicate that a prioritized interrupt is pending and the type of interrupt that is pending. This register will indicate the highest-priority type of interrupt pending for the channel. Individual serial channels prioritize their interrupts into four levels (indicated below), or six levels (IP501-64 models). This helps minimize software overhead during data character transfers. Additionally, with respect to the four channels sharing interrupt request line 0 (IntReq0), interrupts are served according to a shifting priority scheme that is a function of the last interrupting port served.

PRIORITY/LEVEL	INTERRUPT
1	Receiver Line Status
2	Received Data Ready or Character Time-out
3	Transmitter Holding Register Empty
4	Modem Status
5	Software Flow Control Interrupt RxRDY* (Received XOFF signal)/ Special Character
6	CTS*, RTS* Change-of-State

Priority Levels 5 & 6 apply to IP501-64 models only.

The four lower order bits of this register are used to identify the interrupt pending (all units) as shown below. Bits 4 & 5 are used to identify the additional interrupts possible for IP501-64 models.

Interrupt Identification Register (All Models)

BITS 3-0	INT PRTY	INTERRUPT TYPE	INTERRUPT SOURCE	RESET CONTROL
0001	--	None	None	--
0110	1st	Receiver Line Status	OE, PE, FE, or BI (See LSR Bits 1-4)	LSR Read
0100	2nd	Received Data Available	Receiver Data Available or Trigger Level Reached	RBR Read till FIFO below trigger level
1100	2nd	Character Time-out Indication	No characters have been removed from or input to the Rx FIFO during last 4 character times and there is at least 1 character in it during this time	RBR Read
0010	3rd	THRE (LSR Bit 5)	THRE (LSR Bit 5)	IIR Read (if LSR bit 5 is the interrupt source) or a THR Write
0000	4th	Modem Status	CTS* asserted	MSR Read

Bits 4 and 5 of this register are always set to "0" on standard units. Bits 6 and 7 are set to "1" when bit 0 of the FIFO Control Register is set to "1" (bits 6 & 7 are "0" in 16C450 mode). A power-up or system reset sets IIR bit 0 to "1", bits 1-7 to "0".

Interrupt Identification Register (Model IP501-64 Only)

BITS 5 - 4	INT PRTY	INTERRUPT SOURCE
0 1	5	Received XOFF Signal/Special Character
1 0	6	CTS/RTS Change-of-State Detected

Bits 4 & 5 are permanently set to 0 on IP501-16 models.

FCR - FIFO Control Register, Ports A-D (WRITE Only)

This write-only register is used to enable and clear the FIFO buffers, set the trigger level of the Rx FIFO, and select the type of DMA signaling (DMA is NOT supported by this model). IP501-64 models also allow the trigger level of the Tx FIFO to be set. A power-up or system reset will reset all FCR bits to "0".

FIFO Control Register

FCR BIT	FUNCTION
0	When set to "1", this bit enables both the Tx and Rx FIFO's. All bytes in both FIFO's can be cleared by resetting this bit to 0. Data is cleared automatically from the FIFO's when changing from FIFO mode to the alternate (16C450) mode and visa-versa. <u>Programming of other FCR bits is enabled by setting this bit to 1.</u>
1	When set to "1", this bit clears all bytes in the Rx-FIFO and resets the counter logic to 0 (this does not clear the shift register).
2	When set to "1", this bit clears all bytes in the Tx-FIFO and resets the counter logic to 0 (this does not clear the shift register).
3	When set to "1", this bit sets DMA Signal from Mode 0 to Mode 1, if FIFO Control Register Bit 0 = 1 (DMA is Not Supported).
5,4	Not Used on IP501-16 & IP501-16E Models. (IP501-64 Only) Used for setting the trigger level of the Tx FIFO interrupt as follows: BIT 5-4 Tx-FIFO TRIGGER LEVEL 00 08 Bytes for IP501-64 Models Only. 01 16 Bytes for IP501-64 Models Only. 10 32 Bytes for IP501-64 Models Only. 11 56 Bytes for IP501-64 Models Only.
7,6	Used for setting the trigger level of the Rx FIFO interrupt as follows: BIT 7-6 Rx-FIFO TRIGGER LEVEL 00 01 Bytes /08 Bytes for IP501-64 Models 01 04 Bytes /16 Bytes for IP501-64 Models 10 08 Bytes /56 Bytes for IP501-64 Models 11 14 Bytes /60 Bytes for IP501-64 Models

LCR - Line Control Register, Ports A-D (Read/Write)

The individual bits of this register control the format of the data character as follows:

Line Control Register

LCR Bit	FUNCTION	PROGRAMMING
1 and 0	Word Length Select	0 0 = 5 Data Bits 1 0 = 7 Data Bits 0 1 = 6 Data Bits 1 1 = 8 Data Bits
2	Stop Bit Select	0 = 1 Stop Bit 1 = 1.5 Stop Bits if 5 data bits selected, 2 Stop Bits if 6, 7, or 8 data bits selected.
3	Parity Enable	0 = Parity Disabled 1 = Parity Enabled A parity bit is generated and checked for between the last data word bit and the stop bit.
4	Even-Parity Select	0 = Odd Parity 1 = Even Parity
5	Stick Parity	0 = Stick Parity Disabled 1 = Stick Parity Enabled When parity is enabled, stick parity causes the transmission and reception of a parity bit to be in the opposite state from the value selected via bit 4. This is used as a diagnostic tool to force parity to a known state and allow the receiver to check the parity bit in a known state.
6	Break Control	0 = Break Disabled 1 = Break Enabled When break is enabled, the serial output line (TxD) is forced to the space state (low). This bit acts only on the serial output and does not affect transmitter logic. For example, if the following sequence is used, no invalid characters are transmitted due to the presence of the break. 1. Load a zero byte in response to the Transmitter Holding Register Empty (THRE) status indication. 2. Set the break in response to the next THRE status indication. 3. Wait for the transmitter to become idle when the Transmitter Empty status signal is set high (TEMT=1); then clear the break when normal transmission has to be restored.
7	Divisor Latch Access Bit	0 = Access Receiver Buffer 1 = Allow Access to Divisor Latches

Note that writing "BF" to this register allows access to the enhanced register functionality of IP501-64 models.

Note that bit 7 must be set high to access the divisor latch registers of the baud rate generator (DLL & DLM) during a read/write operation. Bit 7 must be low to access the Receiver Buffer register (RBR), the Transmitter Holding Register (THR), or the Interrupt-Enable Register (IER). A power-up or system reset sets all LCR bits to 0.

A detailed discussion of word length, stop bits, parity, and the break signal is included in Section 4.0 (Theory of Operation).

MCR - Modem Control Register, Ports A-D (R/W)

The Modem Control register controls the interface with the modem or data set as described below. For this model, only the RTS and CTS handshake lines are supported and DTR is used to enable the receivers. The RTS output is directly controlled by its control bit in this register (a high input asserts these signals).

A DTR data path is not provided by this model and this output signal via this register (bit 0) is instead used to enable the RxD and CTS receivers of the port. Additionally, asserting the RTS bit will enable the TxD and RTS transmitters of the port if the corresponding Transmit Enable Always Register (TEA) bit is not set.

A power-up or system reset sets all MCR bits to 0 (bits 5-7 are permanently low on standard units).

Modem Control Register

MCR Bit	FUNCTION	PROGRAMMING
0	Data Terminal Ready Output Signal (DTR)	0 = DTR* Not Asserted (Inactive) 1 = DTR* Asserted (Active) A DTR signal path is NOT SUPPORTED by this model. Instead, this output is used to enable the receivers of the port (RxD & CTS receivers).
1	Request to Send Output Signal (RTS)	0 = RTS* Not Asserted (Inactive) 1 = RTS* Asserted (Active)
2	Out1 (Internal)	No Effect on External Operation
3	Out2 (Internal)	0 = External Serial Channel Interrupt Disabled 1 = External Serial Channel Interrupt Enabled
4	Loop ¹	0 = Loop Disabled 1 = Loop Enabled
5,6,7	Not Used on IP501-16 Units	Bits are set to logic 0

Extended Register Functionality (Model IP501-64 Only)

5 ²	XON Enable	0 = Disable Any XON function (Standard 16C550 Mode) 1 = Enable Any XON function
6 ²	Rx/Tx I/O Mode	Not Used on IP501 (set to 0)
7 ²	Clock Divide	0 = Normal divide by 1 clock (8MHz clock baud rates apply) 1 = Divide clock by 4 (2MHz baud rates apply)

Notes (Modem Control Register):

- MCR Bit 4 provides a local loopback feature for diagnostic testing of the UART channel. When set high, the UART serial output (connected to the TXD driver) is set to the marking (logic 1 state), and the UART receiver serial input is disconnected from the RxD receiver path. The output of the UART transmitter shift register is looped back into the receiver shift register input. The four modem control inputs (CTS, DSR, DCD, & RI) are disconnected from their receiver input paths. The four modem control outputs (DTR, RTS, OUT1, & OUT2) are internally connected to the four modem control inputs (while their associated pins are forced to their high/inactive state).
- Bits 5-7 are only programmable when the EFR bit 4 is set to "1". The programmed values for these bits are latched when EFR

bit-4 is cleared, preventing existing software from inadvertently overwriting the extended functions. However, these MCR bits cannot be set if the LCR is set to BF hex.

Thus, in Loopback Mode, transmitted data is immediately received permitting the host processor to verify the transmit and receive data paths of the selected serial channel. In Loopback Mode, interrupts are generated by controlling the state of the four lower order MCR bits internally, instead of by the external hardware paths. However, no interrupt requests or interrupt vectors are served and interrupt pending status is only reflected internally.

Note that on Model IP501-64 units, bits 5-7 are programmable only when the EFR bit 4 is set to "1". The programmed values for these bits are latched when EFR bit 4 is cleared, preventing existing software from inadvertently overwriting the extended functions. A power-up or system reset sets all MCR bits to "0".

LSR - Line Status Register, Ports A-D (Read/Write-Restricted)

The Line Status Register (LSR) provides status indication corresponding to the data transfer. LSR bits 1-4 are the error conditions that produce receiver line-status interrupts (a priority 1 interrupt in the Interrupt Identification Register). The line status register may be written, but this is intended for factory test and should be considered read-only by the applications software.

Line Status Register

LSR Bit	FUNCTION	PROGRAMMING
0	Data Ready (DR)	0 = Not Ready (reset low by CPU Read of RBR or FIFO) 1 = Data Ready (set high when character received and transferred into the RBR or FIFO).
1	Overrun Error (OE)	0 = No Error 1 = Indicates that data in the RBR is not being read before the next character is transferred into the RBR, overwriting the previous character. In the FIFO mode, it is set after the FIFO is filled and the next character is received. The overrun error is detected by the CPU on the first LSR read after it happens. The character in the shift register is not transferred into the FIFO, but is overwritten. This bit is reset low when the CPU reads the LSR.
2	Parity Error (PE)	0 = No Error 1 = Parity Error - the received character does not have the correct parity as configured via LCR bits 3 & 4. This bit is set high on detection of a parity error and reset low when the host CPU reads the contents of the LSR. In the FIFO mode, the parity error is associated with a particular character in the FIFO (LSR Bit 2 reflects the error when the character is at the top of the FIFO).

Line Status Register...continued

LSR Bit	FUNCTION	PROGRAMMING
3	Framing Error (FE)	0 = No Error 1 = Framing Error - Indicates that the received character does not have a valid stop bit (stop bit following last data bit or parity bit detected as a zero/space bit). This bit is reset low when the CPU reads the contents of the LSR. In FIFO mode, the framing error is associated with a particular character in the FIFO (LSR Bit 3 reflects the error when the character is at the top of the FIFO).
4	Break Interrupt (BI)	0 = No Break 1 = Break - the received data input has been held in the space (logic 0) state for more than a full-word transmission time (start bits + data + parity bit + stop bits). Reset upon read of LSR. In FIFO mode, this bit is associated with a particular character in the FIFO and reflects the Break Interrupt when the break character is at the top of the FIFO. It is detected by the host CPU during the first LSR read. Only one "0" character is loaded into the FIFO when BI occurs.
5	Transmitter Holding Register Empty (THRE)	0 = Not Empty 1 = Empty - indicates that the channel is ready to accept a new character for transmission. Set high when character is transferred from the THR into the transmitter shift register. Reset low by loading the THR (It is not reset by a host CPU read of the LSR). In FIFO mode, this bit is set when the Tx FIFO is empty and cleared when one byte is written to the Tx FIFO. When a Transmitter Holding Register Empty interrupt is enabled by IER bit 1, this signal causes a priority 3 interrupt in the IIR. If the IIR indicates that this signal is causing the interrupt, the interrupt is cleared by a read of the IIR.
6	Transmitter Empty (TEMT)	0 = Not Empty 1 = Transmitter Empty - set when both the Transmitter Holding Register (THR) and the Transmitter Shift Register (TSR) are both empty. Reset low when a character is loaded into the THR and remains low until the character is transmitted (it is <u>not reset low by a read of the LSR</u>). In FIFO mode, this bit is set when both the transmitter FIFO and shift register are empty.

Line Status Register...continued

LSR Bit	FUNCTION	PROGRAMMING
7	Receiver FIFO Error	0 = No Error in FIFO (it is always 0 in the 16C450 mode--FCR bit 0 low). 1 = Error in FIFO - set when one of the following data errors is present in the FIFO: parity error, framing error, or break interrupt indication. Cleared by a host CPU read of the LSR if there are no subsequent errors in the FIFO.

Note that LSR Bits 1-4 (OE, PE, FE, BI) are the error conditions that produce a receiver-line-status interrupt (a priority 1 interrupt in the IIR register when any one of these conditions are detected). This interrupt is enabled by setting IER bit 2 to 1.

A power-up or system reset sets all LSR bits to 0, except bits 5 and 6 which are high.

MSR - Modem Status Register, Ports A-D (Read/Write)

The Modem Status Register (MSR) provides the host CPU with an indication on the status of the modem input lines from a modem or other peripheral device. This model only provides support for the CTS and RTS handshake lines. As such, this register allows the current state of CTS to be read (bit 4) and provides indication on whether the state of this line has changed since the last read of the MSR (bit 0 set high when the corresponding control input from the modem changes state and reset low when the CPU reads the MSR).

Modem Status Register

MSR BIT	FUNCTION
0	Δ CTS - Set if CTS has changed states since last read of MSR
1	Δ DSR - NOT SUPPORTED
2	Δ RI - NOT SUPPORTED
3	Δ DCD - NOT SUPPORTED
4	CTS - This bit is the complement of the CTS* input from the modem indicating that the modem is ready to receive data. This bit is equivalent to RTS* in the MCR during local loopback mode. If the channel is in the loopback mode (MCR bit 4 = 1), then the state of RTS in the MCR is reflected. CTS* functions as a hardware flow control signal input if it is enabled via EFR bit 7. The transmit holding register is gated with this input to start/stop the transmission. A high at this pin will stop the transmission as soon as a complete character has been transmitted.
5	DSR - NOT SUPPORTED This bit is equivalent to DTR in the MCR during local loopback mode.
6	RI - NOT SUPPORTED This bit is equivalent to OP1 in the MCR during local loopback mode.
7	DCD - NOT SUPPORTED This bit is equivalent to OP2 in the MCR during local loopback mode. Note that whenever MSR bits 3-0 are set to "1", a modem status interrupt is generated.

An Asterisk (*) is used to indicate an active-low signal.

Note that reading MSR clears the delta-modem status indication (bits 0-3), but has no effect on the other status bits. For both the LSR & MSR, the setting of the status bit during a status register read operation is inhibited (the status bit will not be set until the trailing edge of the read). However, if the same status condition occurs during a read operation, that status bit is cleared on the trailing edge of the read instead of being set again.

In Loopback Mode, when the modem status interrupts are enabled, the CTS* input is ignored. However, a modem status interrupt can still be generated by writing to MCR bit 0 (see Loopback Mode Operation section).

Note that not all UART signal paths are used by this model and their corresponding UART pins are tied high (+5V). This includes, RI (Ring Indicator), DSR (Data Set Ready), and DCD (Data Carrier Detect). In addition, the UART DTR (Data Terminal Ready) signal path is used to control the receiver enables for the port while the RTS signal is used in combination with the TEA (Transmit Enable Always) register to control the transmitter enables for the port.

A power-up or system reset sets MSR bit 0 to 0 (bit 4 is determined by input signal). Unused bits are always clear.

SCR - Scratch Pad/Interrupt Pointer Register, Ports A-D (R/W)

This 8-bit read/write register has no effect on the operation of either serial channel. It is provided as an aide to the programmer to temporarily hold data. Alternately, if interrupt generation is desired, then this port is used to store the interrupt vector for the port. In response to an interrupt select cycle, the IP module will execute a read of this register for the interrupting port (see Interrupt Generation section for more details).

TEA - Transmit Enable Always Register (R/W)

The lower four bits of this register (Bits 0-3) are used to permanently enable the transmitters (the line drivers for TxD and RTS) of a port. Normally, these data paths are enabled via an asserted Request-to-Send (RTS) signal, but may be permanently enabled by setting the respective bit in this register high. Bit 0 controls port A, bit 1 port B, bit 2 port C, and bit 3 port D. Do not use this in conjunction with hardware flow control.

A power-up or system reset clears bits 0-3. The upper four bits of this register are not used and will always read high (1's).

IP Identification PROM - (Read Only, 32 Odd-Byte Addresses)

Each IP module contains an identification (ID) PROM that resides in the ID space per the IP module specification. This area of memory contains 32 bytes of information at most. Both fixed and variable information may be present within the ID PROM. Fixed information includes the "IPAC" identifier, model number, and manufacturer's identification codes. Variable information includes unique information required for the module. The IP501 ID PROM does not contain any variable (e.g. unique calibration) information. ID PROM bytes are addressed using only the odd addresses in a 64 byte block (on the "Big Endian" VMEbus). Even addresses are used on the "Little Endian" PC/ISA bus.

The IP501 ID PROM contents are shown in Table 3.2. Note that the base-address for the IP module ID space (see your carrier board instructions) must be added to the addresses shown to properly access the ID PROM. Execution of an ID PROM Read requires 1 wait state.

Table 3.2: IP501 ID Space Identification (ID) PROM

Hex Offset From ID PROM Base Address	ASCII Character Equivalent	Numeric Value (Hex)	Field Description
01	I	49	All IP's have 'IPAC'
03	P	50	
05	A	41	
07	C	43	
09		A3	Acromag ID Code
0B		05	IP Model Code ¹
0D		00	Not Used (Revision)
0F		00	Reserved
11		00	Not Used (Driver ID Low Byte)
13		00	Not Used (Driver ID High Byte)
15		0C	Total Number of ID PROM Bytes
17		E7	CRC
19 to 3F		yy	Not Used

Notes (Table 3.2):

1. The IP model number is represented by a two-digit code within the ID PROM (IP501 models are represented by 05 Hex).

THE EFFECT OF RESET

A software or hardware reset puts the serial channels into an idle-mode until initialization (programming). A reset initializes the receiver and transmitter clock counters. It also clears the Line-Status Register (LSR), except for the transmitter shift-register empty (TEMT) and transmit holding-register empty (THRE) bits which are set to 1 (note that when interrupts are subsequently enabled, an interrupt will occur due to THRE being set). The Modem Control Register (MCR) and the Transmitter Enable Always Register (TEA) are also cleared. All of the discrete signal lines, memory elements, and miscellaneous logic associated with these register bits are cleared, de-asserted, or turned off. However, the Line Control Register (LCR), divisor latches, Receiver Buffer Register (RBR), and Transmitter Holding Register (THR) are not affected. The following table summarizes the effect of a reset on the various registers and internal and external signals:

The Effect of Reset

REGISTER/SIGNAL	RESET CONTROL	STATE/EFFECT
REGISTERS:		
IER	Reset	All Bits low (Bits 0-3 forced low, Bits 4-7 permanently low).
IIR	Reset	Bit 0 high, Bits 1,2,3,6,7 low, Bits 4 & 5 permanently low.
LCR	Reset	All bits low.
MCR	Reset	All bits low (bits 5-7 permanently low).
FCR	Reset	All bits low.
LSR	Reset	All bits low, except bits 5 & 6 which are high.
MSR	Reset	Bits 0-3 low, bits 4-7 per corresponding input signal.
TEA	Reset	Bits 0-3 low, bits 4-7 are unused and always read high.
EFR	Reset	All bits low.
XON-1,2	Reset	All bits low.
XOFF-1,2	Reset	All bits low.
SIGNALS (INTERNAL & EXTERNAL):		
TxD	Reset	High
Interrupt (RCVR errors)	Read LSR/Reset	Low
Interrupt (RCVR data ready)	Read RCVR Buffer Register/Reset	Low
Interrupt (THRE)	Read IIR/Write THR/Reset	Low
Interrupt (Modem Status Changes)	Read MSR/Reset	Low
RTS*	Reset	High
DTR*	Reset	High
OUT1*	Reset	High
OUT2*	Reset	High

IP501 PROGRAMMING

Each serial channel of this module is programmed by the control registers: LCR, IER, DLL, DLM, MCR, and FCR. These control words define the character length, number of stop bits, parity, baud rate, and modem interface. The control registers can be written in any order, but the IER register should be written last since it controls the interrupt enables. The contents of these registers can be updated any time the serial channel is not transmitting or receiving data.

The complete status of each channel can be read by the host CPU at any time during operation. Two registers are used to report the status of a particular channel: the Line Status Register (LSR) and the Modem Status Register (MSR).

Serial channel data is read from the Receiver Buffer Register (RBR), and written to the Transmitter Holding Register (THR). Writing data to the THR initiates the parallel-to-serial transmitter shift register to the TxD line. Likewise, input data is shifted from the RxD pin to the Receiver Buffer Register. The DTR bit of the Modem Control Register (MCR bit 0) is used to enable the RxD and CTS receivers of the port. Additionally, asserting the RTS bit will enable the TxD and RTS transmitters of the port if the corresponding Transmit Enable Always Register (TEA) bit is not set.

The Scratchpad Register is used to store the interrupt vector for the port. In response to an interrupt select cycle, the IP module will provide a read of this port. As such, each port may have a unique interrupt vector assigned. Interrupts are served in a shifting-priority fashion that is a function of the last interrupting port serviced. This prevents continuous interrupts from one channel from freezing out service of another interrupting channel.

This board operates in two different modes. In one mode, this device remains software compatible with the industry standard 16C450 family of UART's, and provides double-buffering of data registers. In the FIFO Mode (enabled via bit 0 of the FCR register), data registers are FIFO-buffered so that read and write operations can be performed while the UART is performing serial-to-parallel and parallel-to-serial conversions.

Two FIFO modes of operation are possible: FIFO Interrupt Mode and FIFO Polled Mode. In FIFO Interrupt Mode, data transfer is initiated by reaching a pre-determined trigger-level or generating time-out conditions. In FIFO-Polled Mode, there is no time-out condition indicated or trigger-level reached. The transmit and receive FIFO's simply hold characters and the Line Status Register must be read to determine the channel status.

Acromag provides an Industrial I/O Pack Software Library diskette (Model IPSW-LIB-M03, MSDOS format) to simplify communication with the board. Example software functions are provided for both ISA bus (PC/AT) and VMEbus applications. All functions are written in the "C" programming language and can be linked to your application. For more details, refer to the "README.TXT" file in the root directory on the diskette and the "INFO501.TXT" file in the appropriate "IP501" subdirectory off of "VMEIP" or "PCIP", according to your carrier.

FIFO Polled-Mode

Resetting Interrupt Enable Register Bit 0, Bit 1, Bit 2, Bit 3, or all four to 0, with FIFO Control Register (FCR) Bit 0 =1, puts the channel into the polled-mode of operation. The receiver and transmitter are controlled separately and either one or both may be in the polled mode. In FIFO-Polled Mode, there is no time-out condition indicated or trigger-level reached, the transmit and the receive FIFO's simply hold characters and the Line Status Register must be read to determine the channel status.

FIFO-Interrupt Mode

In FIFO Interrupt Mode, data transfer is initiated by reaching a pre-determined trigger-level or generating a time-out condition. Please note the following with respect to this mode of operation.

When the receiver FIFO and receiver interrupts are enabled, the following receiver status conditions apply:

1. LSR Bit 0 is set to 1 when a character is transferred from the shift register to the receiver FIFO. It is reset to 0 when the FIFO is empty.
2. The receiver line-status interrupt (IIR=06) has a higher priority than the received data-available interrupt (IIR=04).
3. The receive data-available interrupt is issued to the CPU when the programmed trigger level is reached by the FIFO. It is cleared when the FIFO drops below its programmed trigger level. The receive data-available interrupt indication (IIR=04) also occurs when the FIFO reaches its trigger level, and is cleared when the FIFO drops below its trigger level.

When the receiver FIFO and receiver interrupts are enabled, the following receiver FIFO character time-out status conditions apply:

1. A FIFO character time-out interrupt occurs if:
 - A minimum of one character is in the FIFO.
 - The last received serial character is longer than four continuous prior character times ago (if 2 stop bits are programmed, the second one is included in the time delay).
 - The last CPU read of the FIFO is more than four continuous character times earlier. At 300 baud, and with 12-bit characters, the FIFO time-out interrupt causes a latency of 160ms maximum from received character to interrupt issued.
2. From the clock signal input, the character times can be calculated. The delay is proportional to the baud rate.
3. The time-out timer is reset after the CPU reads the receiver FIFO or after a new character is received when there has been no time-out interrupt.
4. A time-out interrupt is cleared and the timer is reset when the CPU reads a character from the receiver FIFO.

When the transmit FIFO and transmit interrupts are enabled (FCR Bit 0 = 1 and IER=01), a transmitter interrupt will occur as follows:

1. When the transmitter FIFO is empty, the transmitter holding register interrupt (IIR=02) occurs. The interrupt is cleared when the Transmitter Holding Register (THR) is written to or the Interrupt Identification Register (IIR) is read. One to sixteen characters can be written to the transmit FIFO when servicing this interrupt.
2. The transmit FIFO empty indications are delayed one character time minus the last stop bit time when the following occurs: Bit 5 of the LSR (THRE) is 1 and there is not a minimum of two bytes at the same time in the transmit FIFO since the last time THRE=1. The first transmitter interrupt after changing FCR Bit 0 is immediate, assuming it is enabled.

The receiver FIFO trigger level and character time-out interrupts have the same priority as the received data-available interrupt. The Transmitter Holding-Register-Empty interrupt has the same priority as the Transmitter FIFO-Empty interrupt.

Loopback Mode Operation

This device can be operated in a “loopback mode”, useful for troubleshooting a serial channel without physically wiring to the channel. Bit 4 of the Modem Control Register (MCR) is used to program the local loopback feature for the UART channel. When set high, the UART channel’s serial output line (Transmit Data Path) is set to the marking (logic 1 state), and the UART receiver serial data input lines are disconnected from the RxD receiver path. The output of the UART transmitter shift register is then looped back into the receiver shift register input. Thus, a write to the Transmitter Holding Register is automatically looped back to the corresponding Receiver Buffer Register. Additionally, the four modem control inputs (CTS, DSR, DCD, and RI) are disconnected from their receiver input paths. With modem status interrupts enabled in the Loopback Mode, the CTS*, DSR*, RI*, and DCD* inputs are ignored. Instead, the four modem control outputs (DTR, RTS, OUT1, and OUT2 of the MCR Register) are internally connected to the corresponding four modem control inputs (monitored via the Modem Status Register), while their associated pins are forced to their high/ inactive state. Thus, in the loopback diagnostic mode, transmitted data is immediately received permitting the host processor to verify the transmit and receive data paths of the selected serial channel. Further, modem status interrupt generation is controlled manually in loopback mode by controlling the state of the four lower order MCR bits internally, instead of by the external hardware paths. However, in loopback mode, no interrupt requests or interrupt vectors will actually be served, the UART only reflects that an interrupt is pending.

Interrupt Generation

This model provides individual control for generation of transmit, receive, line status, and data set interrupts on each of four channels. Each channel shares interrupt request line 0 (Intreq0) according to a unique priority shifting scheme that prevents the continuous interrupts of one channel from freezing out another channels’ interrupt requests.

After pulling the IntReq0 line low and in response to an Interrupt Select cycle, the current highest priority interrupt channel will serve up its interrupt vector first. Interrupt serving priority will shift as a function of the last port served. A unique interrupt vector may be assigned to each communication port and is loaded into the Scratchpad Register (SCR) for the port. The IP module will thus execute a read of the Scratchpad Register in response to an interrupt select cycle. Two wait states are required to complete this cycle.

Interrupt priority is assigned as follows. Initially, with no prior interrupt history, Port A has the highest priority and will be served first, followed by port B, followed by port C, then followed by port D. However, if port A was the last interrupt serviced, then port B will have the highest priority, followed by port C, followed by port D, then port A, in a last-served last-out fashion. Priority continues to shift in the same fashion if port B or port C was the last interrupt serviced. This is useful in preventing continuous interrupts on one channel from freezing out interrupt service for other channels.

Software Flow Control (Model IP501-64 Only)

Model IP501-64 modules include support for software flow control. Software flow control utilizes special XON & XOFF characters to control the flow of data, for more efficient data transfer and to minimize overrun errors.

Software flow control (sometimes called XON/XOFF pacing) sends a signal from one node to another by adding flow control characters to the data stream. The receiving node will detect the XON or XOFF character and respond by suspending transmission of data (XOFF turns the data flow off), or resuming transmission of data (XON turns the data flow on). Flow control is used frequently in data communications to prevent overrun errors or the loss of excess data. For example, a node might transmit the XOFF character to the host computer if the host is sending data too quickly to be processed or buffered, thus preventing the loss of excess data.

The flow control characters are stored in the XON-1,2 and XOFF-1,2 registers. Two XON & XOFF registers are provided because the flow control character may be 1 or 2 bytes long. The contents of the XON-1,2 and XOFF-1,2 registers are reset to “0” upon power-up or system reset, and may be programmed to any value for software flow control. Different conditions may be set to detect the XON/XOFF characters or start/stop the transmission.

When software flow control is enabled, the UART of this model will compare two sequential received data bytes with preprogrammed XOFF-1,2 characters. When an XOFF match is detected, the UART will halt transmission after completing the transmission of the current character. The receive ready flag of the Interrupt Identification register will be set (IIR bit 4 is set to “1” when the XOFF character has been detected), only if enabled via bit 5 of the Interrupt Enable register (IER bit 5 is used to enable the received XOFF interrupt). An interrupt will then be generated. After recognition of the XOFF characters, the UART will compare the next two incoming characters with the preprogrammed XON-1,2 characters. If a match is detected, the UART will resume transmission and clear the received XOFF interrupt flag (Interrupt Identification Register bit 4). After more data has been received, the UART will automatically send XOFF-1,2 characters as soon as the received data passes the programmed FIFO trigger level, causing the host to suspend transmission. The UART will then transmit the programmed XON-1,2 characters as soon as the received data reaches the next lowest trigger level, thus causing the host to resume transmission (received data trigger levels are 8, 16, 56, and 60).

When single XON/XOFF characters are selected, the UART compares the received data to these values and controls the transmission accordingly (XON=restart transmission, XOFF=suspend transmission). These characters are not stacked in the data buffer or FIFO. When the ANY XON function is enabled (MCR bit 5 is set), the UART will automatically resume transmission after receiving ANY character after having recognized XOFF and suspended transmission. Note that the UART will automatically transmit the XON character(s) after the flow control function is disabled, if the XOFF character(s) had been sent prior to disabling the software flow control function. Special cases are provided to detect the special character and stack it into the data buffer or FIFO and these conditions are configured via bits 0-3 of the Enhanced Feature Register (EFR).

Hardware Flow Control (Model IP501-64 Only)

Model IP501-64 modules include support for hardware flow control via the RTS & CTS signals. This is useful for increasing the efficiency of the data transfer and for minimizing overrun errors.

Hardware flow control can be selected when either or both bits 6 & 7 of the EFR register are set to "1". Bit 6 is used to select Auto-RTS, Bit 7 selects Auto-CTS*. With hardware flow control enabled, the UART monitors the CTS* signal for transmit operation and the receiver trigger level for RTS* operation. When auto CTS is selected, the UART will automatically suspend data transmission as soon as a complete character is transmitted and the CTS input level changes from low to high (deasserted). Additionally, ISR bit 5 will be set (if enabled via IER bits 6-7). Transmission will resume as soon as the CTS* signal changes to the low level (CTS* asserted).

When Auto-RTS* is selected, the RTS* signal will be forced to the high (deasserted) state when the receiver FIFO reaches a programmed trigger level. RTS* will go low (asserted) when the receiver holding register contents drops below the next-lower trigger level (received data trigger levels are 8, 16, 56, and 60). The UART will accept additional data when the transmission is suspended during hardware flow control until all FIFO locations are filled. Note that Auto-RTS* is functional only when MCR bit 1 is set to "1" (it is "AND-ed" with MCR bit 1). The RTS* signal can change states by setting MCR bit 1 to "0" or "1". This provides additional flexibility for manual over-ride and to maintain the hardware flow control functionality.

Both hardware and software flow controls can be enabled for automatic operation. In this mode, the UART will accept additional data to fill the unused transmit and receive FIFO locations.

Programming Example

The following example will demonstrate data transfer between one channel of the host IP501 and another node using an RTS/CTS protocol. Both nodes will use the FIFO mode of operation with a FIFO threshold set at 14 bytes. The data format will use 8-bit characters, odd-parity, and 1 stop bit. Please refer to Table 3.1 for address locations. The "H" following data below refers to the Hexadecimal data format.

1. Write 80H to the Line Control Register (LCR).

This sets the Divisor Latch Access bit to permit access to the two divisor latch bytes used to set the baud rate. These bytes share addresses with the Receive and Transmit buffers, and the Interrupt Enable Register (IER).

2. Write 00H to the Divisor Latch MSB (DLM). Write 34H to the Divisor Latch LSB (DLL).

This sets the divisor to 52 for 9600 baud (i.e. $9600 = 8\text{MHz} \div [16 \times 52]$).

3. Write 0BH to the Line Control Register (LCR).

This first turns off the Divisor Latch Access bit to cause accesses to the Receiver and Transmit buffers and the Interrupt Enable Register. It also sets the word length to 8 bits, the number of stop bits to one, and enables odd-parity.

4. (OPTIONAL) Write xxH to the Scratch Pad Register.

This has no effect on the operation, but is suggested to illustrate that this register can be used as a 1-byte memory cell. Alternately, the interrupt vector for the port may be written to this register and a read will be performed on this register in response to an interrupt select cycle.

5. Write 0FH to the Interrupt Enable Register (IER).

This enables the modem status interrupts and the receiver line status interrupts. The modem status interrupt is used to signal changes in CTS* to handle the protocol. The line status interrupt is used to signal error cases, such as parity or overrun errors. The modem status interrupts are expected, but the line status interrupts are not. The received data available and transmit holding buffer empty interrupts have also been enabled to aide control by the host CPU in moving data back and forth.

6. Write C7H to the FIFO Control Register (FCR).

This enables and initializes the transmit and receive FIFO's, and sets the trigger level of the receive FIFO interrupt to 14 bytes.

7. Read C1H from the Interrupt Identification Register (IIR).

This is done to check that the device has been programmed correctly. The upper nibble "C" indicates that the FIFO's have been enabled and the lower nibble "1" indicates that no interrupts are pending.

8. Write 02H to the Modem Control Register (MCR).

This sets the Request-To-Send bit and asserts the RTS* signal line. It is used to signal a receiver that the device is ready to transmit some data. Note the modem control lines, either input or output, have no effect on the parallel-to-serial output data or serial-to-parallel input data. These lines interact only through CPU control to provide the handshaking necessary for this data transfer protocol.

9. Read 11H from the Modem Status Register (MSR)

This is an indication from the receiver that the Clear-To-Send signal has been asserted and that there has been a change in the CTS* signal since the last read of the MSR. Consequently, an interrupt will be generated on INTREQ0* to signal the host CPU that it can begin loading data into the transmit buffer.

10. The host should acknowledge the interrupt to clear it (execute an interrupt select cycle), then begin writing data repeatedly to the Transmitter Holding Register.

This loads the transmit FIFO and initiates transmission of serial data on the TxD line. The first serial byte will take about 100us to transmit, so it is likely that the transmit FIFO will fill before the first byte has been sent.

The receiving side may release CTS* if it cannot keep up with the data stream. In this case, the host CPU would have to pause in loading the data to prevent lost data.

11. Stop loading the transmit buffer, then write 00H to the Modem Control Register (MCR).

This clears the Request-To-Send bit and releases the RTS* signal line, signifying that transmission is complete.

12. Read 01H from the Modem Status Register (MSR).

This indicates that the receiving side has released its Clear-To-Send (CTS*) signal in response to the transmitting side dropping its Request-To-Send signal (RTS*).

13. Read data repeatedly from the Receiver Buffer Register.

After 14 bytes have been received (or fewer bytes with a timeout), an interrupt will be generated if the host CPU has not unloaded the receive FIFO.

4.0 THEORY OF OPERATION

This section contains information regarding the TIA/EIA-422B serial data interface. A description of the basic functionality of the circuitry used on the board is also provided. Refer to Block Diagram (Drawing 4501-553), Interface Diagram (Drawing 4501-554), and Interface Levels (Drawing 4501-570), as you review this material.

EIA/TIA-422B SERIAL INTERFACE

The Electronic Industries Association (EIA) in conjunction with the Telecommunication Industries Association (TIA) introduced TIA/EIA-422B as a balanced (differential) serial data transmission interface standard between Data Terminal Equipment (DTE) and Data Communication Equipment (DCE). By definition, DTE is commonly used to represent the data source, data sink, or both. DCE is used to represent the devices used to establish, maintain, and terminate a connection, and to code/decode the signals between the DTE and the transmission channel. Most computers are considered DTE devices, while modems are DCE devices.

The EIA/TIA-422B interface is the second revision of this standard and specifies a balanced driver with balanced receivers. Balanced data transmission refers to the fact that two conductors are switched per signal and the logical state of the data is referenced by the difference in potential between the two conductors, not with respect to signal ground. The differential method of data transmission makes EIA-422B ideal for noisy environments since it minimizes the effects of coupled noise and ground potential differences. That is, since these effects are seen as common-mode voltages (common to both lines), not differential, they are rejected by the receivers. Additionally, balanced drivers have faster transition times and allow operation at higher data rates over longer distances.

The EIA/TIA-422B standard defines a unidirectional, terminated, single driver and multiple receiver configuration. By providing a separate data path for transmit and receive, full-duplex operation is accomplished. The maximum data transmission cable length is generally limited to 4000 feet without a signal repeater installed.

EIA/TIA-422B is electrically similar to EIA-485, except that EIA-485 supports multiple driver operation. Consequently, this board may be used to implement a full-duplex EIA-485 interface (see Drawing 4501-554). However, for true half-duplex EIA-485 operation, please see the Acromag Model IP502.

With respect to EIA/TIA-422B, logic states are represented by differential voltages from 2V to 10V. The polarity of the differential voltage determines the logical state. A logic 0 (the 'space' or ON state) is represented by a negative differential voltage between the terminals (measured A to B, or + to -). A logic 1 (the 'mark' or OFF state) is represented by a positive differential voltage between the terminals (measured A to B, or + to -). However, for the RTS and CTS lines of the IP501, a logic 0 is the ON state and this is generated by a positive differential voltage. This is because the A & B lines for the RTS driver and CTS receiver of the IP501 are flipped to provide the inversion required by the UART for these handshake lines. The line receivers convert the interface signals to the conventional TTL level associations required by the UART. The line drivers convert the TTL signals of the UART to the differential voltages required at the interface (Refer to Drawing 4501-570).

EIA/TIA-422B	BINARY 0 (SPACE/ON)	BINARY 1 (MARK/OFF)
SIGNAL A to B (+) to (-)	Negative Differential Voltage	Positive Differential Voltage

Start and stop bits are used to synchronize the receiver (DCE) to the asynchronous serial data of the transmitter (DTE). The transmit data line is normally held in the mark state (logical 1). The transmission of a data byte requires that a start bit (a logical 0 or a transition from mark to space) be sent first. This tells the receiver that the next bit is a data bit. The data bits are followed by a stop bit (a logical 1 or a return to the mark state). The stop bit tells the receiver that a complete byte has been received. Thus, 10 bits make up a data byte if the data character is 8 bits long (and no parity is assumed). Nine bits are required if only standard ASCII data is being transmitted (1 start bit + 7 data bits + 1 stop bit). The character size for this module is programmable from 5 to 8 bits.

Parity is a method of judging the integrity of the data. Odd, even, or no parity may be configured for this module. If parity is selected, then the parity bit precedes transmission of the stop bit. The parity bit is a 0 or 1 bit appended to the data to make the total number of 1 bits in a byte even or odd. Parity is not normally used with 8-bit data. Even parity specifies that an even number of logical 1's be transmitted. Thus, if the data byte has an odd number of 1's, then the parity bit is set to 1 to make the parity of the entire character even. Likewise, if the transmitted data has an even number of 1's, then the parity bit is set to 0 to maintain even parity. Odd parity works the same way using an odd number of logical 1's. Thus, both the transmitter and receiver must have the same parity. If a byte is received that has the wrong parity, an error is assumed and the sending system is typically requested to retransmit the byte. Two other parity formats not supported by this module are mark parity and space parity. Mark parity specifies that the parity bit will always be a logical 1, space parity requires that the parity bit will always be 0.

The most common asynchronous serial data format is 1 start bit, 8 data bits, and 1 stop bit, with no parity. The following table summarizes the available data formats:

START BIT	Binary 0 (a shift from "Mark" to "Space")
DATA BITS	5,6,7, or 8 Bits
PARITY	Odd, Even, or None
STOP BIT	Binary 1 (1, 1-1/2, or 2 Bit times)

With start, stop, and parity in mind, for an asynchronous data byte, note that at least one bit will be a 1 (the stop bit). This defines the break signal (all 0 bits with a 1 stop bit lasting longer than one character). A break signal is a transfer from "mark" to "space" that lasts longer than the time it takes to transfer one character. Because the break signal doesn't contain any logical 1's, it cannot be mistaken for data. Typically, whenever a break signal is detected, the receiver will interpret whatever follows as a command rather than data. The break signal is used whenever normal signal processing must be interrupted. In the case of a modem, it will usually precede a modem control command. Do not confuse the break signal with the ASCII Null character, since a break signal is longer than one character time. That is, it is any "space" condition on the line that lasts longer than a single character (including its framing bits) and is usually 1-1/2 to 2 character times long.

The baud rate is a unit of transmission speed equal to the number of electrical signals (signal level changes) sent on a line in one second. It is thus, the electrical signaling rate or frequency at which electrical impulses are transmitted on a communication line. The baud rate is commonly confused with the bit transfer rate (bits-per-second), but baud rate does not equate to the number of bits transmitted per second unless one bit is sent per electrical signal. However, one electrical signal (change in signal level) may contain more than one bit (as is the case with most phone modems). While bits-per-second (bps) refers to the actual number of bits transmitted in one second, the baud rate refers to the number of signal level changes that may occur in one second. Thus, 2400 baud does not equal 2400 bits per second unless 1 bit is sent per electrical signal. Likewise, a 1200bps or 2400bps modem operates at a signalling rate of only 600 baud since they encode 2 and 4 bits, respectively, in one electrical impulse (through amplitude, phase, and frequency modulation techniques). However, for this device, the baud rate is considered equivalent to the bit rate.

This model includes a separate data path for Transmit and Receive, providing full-duplex communication. Paths for the two most common handshake signals, Request to Send (RTS) and Clear to Send (CTS), are also included.

Pins 1-18 and pins 26-43 of the field I/O connector P2 provide connectivity to serial Ports A-D of this module (Refer to Table 2.1 for pin assignments). Note that a suffix of '_A', '_B', '_C', or '_D' is appended to the signal names to indicate their port association. Each of these signals are described in detail below assuming that a local DTE device (PC) is connected to a local DCE device (modem) communicating over a telephone line to a remote DCE device (remote modem) connected to a remote DTE (another PC).

Note that not all UART signal paths are used by this model and their corresponding UART pins are tied high (+5V). This includes, RI (Ring Indicator), DSR (Data Set Ready), and DCD (Data Carrier Detect). In addition, the UART DTR (Data Terminal Ready) signal path is used to control the receiver enables for the port. The RTS signal is used in combination with the TEA (Transmit Enable Always) register to control the transmitter enables for the port.

EIA/TIA-422B Signal Descriptions

SIGNAL ±	DESCRIPTION
RxD_A RxD_B RxD_C RxD_D	Receive Data Path (DCE-to-DTE)- This is the receive data path from the remote receiver to the host transmitter. The signals on these lines are in serial form. When DCD is held off, this line is held in the mark state.
TxD_A TxD_B TxD_C TxD_D	Transmit Data Path (DTE-to-DCE) - This is the transmit data path from the DTE to the modem. When no data is being transmitted, the signal path is held in the mark state. Normally, for data to be transmitted, DSR, DTR, RTS, and CTS must all be in the on state (asserted). A DSR data path is not provided by this model. Additionally, a DTR data path is not available and this output signal is instead used to enable the RxD and CTS receivers of the port.
RTS_A* RTS_B* RTS_C* RTS_D*	Request-to-Send (DTE-to-DCE) - RTS is turned on by the DTE to tell the DCE it is ready to transmit data. This is also passed to the remote DCE. The DCE will turn CTS on in response to tell the DTE it is ready to receive data. As such, RTS acts to control the direction of data transmission. It is turned ON in transmit mode and turned OFF when transmission is completed or in receive mode (the DCE will turn CTS off in response).
CTS_A* CTS_B* CTS_C* CTS_D*	Clear-to-Send (DCE-to-DTE) - CTS is turned on by the DCE to indicate it is ready to receive data from the DTE and the local modem has control over the telephone line. CTS is turned on in response to simultaneous conditions of the RTS, DSR, and DTR signals.
DTR_A* DTR_B* DTR_C* DTR_D*	Data Terminal Ready (DTE-to-DCE) - Normally, DTR is used in conjunction with DSR to indicate equipment readiness. DTR is turned on by the DTE to tell the DCE it is ready to receive or transmit data. However, a DTR data path is not provided by this model and this output signal is instead used to enable the RxD and CTS receivers of the port.

An Asterisk (*) is used to indicate an active-low signal.

IP501 OPERATION

Connection to each serial port is provided through connector P2 (refer to Table 2.1). These pins are tied to the inputs and outputs of EIA/TIA-422B line receivers and drivers. The function of the line receivers are to convert the required EIA/TIA-422B voltage signals to the TTL levels required by the UART (Universal Asynchronous Receiver/Transmitter). The line drivers convert the UART TTL levels to the EIA/TIA-422B voltages. The UART provides the necessary conversion from serial-to-parallel (receive) and parallel-to-serial (transmit) for interfacing to the data bus. Additionally, it provides data buffering and data formatting capabilities.

A programmable logic device is used to control the interface between the UART, the IP bus, the line drivers and receivers, and the IDPROM.

Note that the field serial interface to the carrier board provided through connector P2 (refer to Table 2.1) is NON-ISOLATED. This means that the field signal return and logic common have a direct electrical connection to each other. As such, care must be taken to avoid ground loops (see Section 2 for connection recommendations). Ignoring this effect may cause operation errors, and with extreme abuse, possible circuit damage. Refer to Drawing 4501-552 for example communication wiring and grounding connections.

LOGIC/POWER INTERFACE

The logic interface to the carrier board is made through connector P1 (refer to Table 2.2). Not all of the IP logic P1 pin functions are used. P1 also provides +5V to power the module ($\pm 12V$ is not used).

A programmable logic device installed on the IP Module provides the control signals required to operate the board. It decodes the selected addresses in the I/O and ID spaces and produces the chip selects, control signals, and timing required by the communication registers and ID PROM, as well as, the acknowledgement signal required by the carrier board per the IP specification. It also prioritizes the interrupt requests coming from the serial ports in a shifting priority fashion, based on the last interrupt serviced.

The ID PROM (read only) installed on the IP module provides the identification for the individual module per the IP specification. The ID PROM, configuration control registers, and FIFO buffers are all accessed through an 8-bit data bus interface to the carrier board.

5.0 SERVICE AND REPAIR

SERVICE AND REPAIR ASSISTANCE

Surface-Mounted Technology (SMT) boards are generally difficult to repair. It is highly recommended that a non-functioning board be returned to Acromag for repair. The board can be easily damaged unless special SMT repair and service tools are used. Further, Acromag has automated test equipment that thoroughly checks the performance of each board. When a board is first produced and when any repair is made, it is tested, placed in a burn-in room at elevated temperature, and retested before shipment.

Please refer to Acromag's Service Policy Bulletin or contact Acromag for complete details on how to obtain parts and repair.

PRELIMINARY SERVICE PROCEDURE

Before beginning repair, be sure that all of the procedures in Section 2, Preparation For Use, have been followed. Also, refer to the documentation of your carrier board to verify that it is correctly configured. Replacement of the module with one that is known to work correctly is a good technique to isolate a faulty module.

CAUTION: POWER MUST BE TURNED OFF BEFORE REMOVING OR INSERTING BOARDS

Acromag's Applications Engineers can provide further technical assistance if required. When needed, complete repair services are also available from Acromag.

6.0 SPECIFICATIONS

GENERAL SPECIFICATIONS

UART.....	Texas Instruments TL16C554FN or Startech ST16C554DCJ68 (IP501-16); Startech ST16C554DIJ68 (IP501-16E); Startech ST16C654CJ68 (IP501-64)
Operating Temperature.....	0 to +70°C (IP501-16, IP501-64); -40°C to +85°C (IP501-16E);
Relative Humidity.....	5-95% non-condensing.
Storage Temperature.....	-40°C to +125°C.
Physical Configuration.....	Single Industrial I/O Pack Module.
Length.....	3.880 inches (98.5 mm).
Width.....	1.780 inches (45.2 mm).
Board Thickness.....	0.062 inches (1.59 mm).
Max Component Height.....	0.314 inches (7.97 mm).
Connectors:	
P1 (IP Logic Interface).....	50-pin female receptacle header (AMP 173279-3 or equivalent).
P2 (Field I/O).....	50-pin female receptacle header (AMP 173279-3 or equivalent).
Power:	
+5 Volts ($\pm 5\%$).....	300mA, Typical with transmitter terminating resistors removed; 535mA, Typical with all Termination & Bias Resistors installed; 650mA, Maximum.
+12 Volts ($\pm 5\%$) from P1.....	0mA (Not Used).
-12 Volts ($\pm 5\%$) from P1.....	0mA (Not Used).
Non-Isolated.....	Logic and field commons have a direct electrical connection.
Resistance to RFI.....	No data upsets occur for field strengths up to 10V per meter at 27MHz, 151MHz, & 460MHz per SAMA PMC 33.1 test procedures.
Resistance to EMI.....	Unit has been tested with no data upsets under the influence of EMI from switching solenoids, commutator motors, and drill motors.
Surge Withstand Capability.....	Interface lines exhibit no damage when tested with a standardized test waveform representative of surges (high frequency transient electrical interference) per ANSI/IEEE C37.90-1978.
ESD Protection.....	EIA/TIA-422B lines are protected from ESD voltages to $\leq \pm 10KV$.

EIA/TIA-422B PORTS

Configuration.....Four independent, non-isolated, EIA/TIA-422B serial ports with a common signal return connection.

Data Rate.....Programmable to 512K bits/sec using internal baud rate generator.

Interface.....Asynchronous serial only.

Maximum Cable Length.....1200M (4000 feet) typical. Use of a signal repeater can extend transmission distances beyond this limit.

Character Size.....Software programmable 5-8 bits.

Parity.....Software Programmable odd, even, or no parity.

Stop Bits.....Software programmable 1, 1-1/2, or 2 bits.

Data Register Buffers.....The data registers are double-buffered (16C450 mode), or 16-byte FIFO buffered (FIFO mode).

Interrupts.....Receiver Line Status Interrupt (i.e. Overrun error, Parity error, Framing error, or Break Interrupt); Received Data Available (FIFO level reached) or Character Time-Out; Transmitter Holding Register Empty; or Modem Status (CTS, DSR, RI, or DCD). Multiple port Interrupts share the IntReq0 line according to a shifting-priority scheme based on the last interrupting port serviced. IP501-64 units also include interrupts for received XOFF signal/special character.

DRIVERS:

Termination Resistors.....120Ω Termination Resistors are installed in sockets on board and may be removed if required (see Drawing 4501-555 for location). Install termination resistors at the end of a network only.

Bias Resistors.....560Ω pullup to +5V on (+) output lines, 560Ω pull-down to COM on (-) lines, installed in sockets on board and may be removed if required (see Drawing 4501-555 for location). Only one set of bias resistors should be installed per line pair.

Line Driver.....Linear Technology LTC487CS, or equivalent. Designed for EIA/TIA-422B or EIA-485 applications.

Differential Output Voltage5V Maximum (Unloaded); 2V Minimum (EIA/TIA-422B, 50Ω load); 1.5V Minimum (EIA-485, 27Ω load).

Common Mode Output Voltage.....3V Maximum

Output Short Circuit Current.....250mA Maximum

Rise or Fall Time.....5ns Minimum, 20ns Typical, 71nS Maximum (R_{DIFF} = 54Ω, C_L = 100pF).

High-Z State Output Current.....±200uA Maximum.

RECEIVERS:

Termination Resistors.....120Ω Termination Resistors Installed in sockets on board (see Drawing 4501-555 for location).

Line Receiver.....Linear Technology LTC489CS or equivalent.

Data Rate.....Up to 512 Kbps.

Differential Input Threshold.....-0.2V Minimum to +0.2V Maximum.

Input Hysteresis.....60mV (V_{CM}=0V).

Input Resistance.....12KΩ

Propagation Delay (High-to-Low)..55ns Maximum (C_L=15pF).

Propagation Delay (Low-to-High)..55ns Maximum (C_L=15pF).

INDUSTRIAL I/O PACK COMPLIANCE

Specification.....This module meets or exceeds all written Industrial I/O Pack specifications per revision 0.7.1.

Electrical/Mechanical Interface....Single-Size IP Module.

IP Data Transfer Cycle Types Supported:

 Input/Output (IOSel*).....D16 or D08 least significant read/write of data.

 ID Read (IDSel*).....32 x 8 ID PROM read on D0..D7.

 Interrupt Select (INTSel*).....8-bit word (D08) read of Scratch Pad/Interrupt Vector Register contents.

Access Times (8MHz Clock):

 ID PROM Read.....1 wait state (375ns cycle).

 Channel Register Read.....2 wait states (500ns cycle).

 Channel Register Write.....2 wait states (500ns cycle).

 Interrupt Select Read.....2 wait states (500ns cycle).

APPENDIX

**CABLE: MODEL 5025-550-x (Non-Shielded)
MODEL 5025-551-x (Shielded)**

Type: Flat Ribbon Cable, 50-wires (female connectors at both ends). The '-x' suffix designates the length in feet (12 feet maximum). Choose shielded or unshielded cable according to model number. The unshielded cable is recommended for digital I/O, while the shielded cable is recommended for optimum performance with precision analog I/O applications.

Application: Used to connect a Model 5025-552 termination panel to the AVME9630/9660 or APC8610 non-intelligent carrier board A-D connectors (both have 50-pin connectors).

Length: Last field of part number designates length in feet (user-specified, 12 feet maximum). It is recommended that this length be kept to a minimum to reduce noise and power loss.

Cable: 50-wire flat ribbon cable, 28 gage. Non-Shielded cable model uses Acromag Part 2002-211 (3M Type C3365/50 or equivalent). Shielded cable model uses Acromag Part 2002-261 (3M Type 3476/50 or equivalent).

Headers (Both Ends): 50-pin female header with strain relief. *Header* - Acromag Part 1004-512 (3M Type 3425-6600 or equivalent). *Strain Relief* - Acromag Part 1004-534 (3M Type 3448-3050 or equivalent).

Keying: Headers at both ends have polarizing key to prevent improper installation.

Schematic and Physical Attributes: For Non-Shielded cable model, see Drawing 4501-462. For Shielded cable model, see Drawing 4501-463.

Shipping Weight: 1.0 pound (0.5Kg) packaged.

CABLE: MODEL 5029-943

Type: Model 5029-943 IP500 Communication Cable: A five foot long, flat 50-pin cable with a female connector on one end (for connection to AVME9630/9660 or other compatible carrier boards) and four DE-9P connectors (serial ports) on the other end.

Application: Used to connect up to four DB-9 serial ports to AVME9630/9660 non-intelligent carrier board A-D connectors. It is used primarily with Acromag Model IP500, IP501, & IP502 serial communication modules.

Length: 5 feet.

Cable: 50-wire flat ribbon cable, 28 gage. Non-Shielded cable model uses Acromag Part 2002-211 (3M Type C3365/50 or equivalent).

Headers: 50-pin female header with strain relief. *Header* - Acromag Part 1004-512 (3M Type 3425-6600 or equivalent). *Strain Relief* - Acromag Part 1004-534 (3M Type 3448-3050 or equivalent).

Port Connectors: Four DE-9P (9-pin, D-SUB, Male) connectors with strain relief (3M connector U89809-9000 with 3448-8D09A strain relief, or equivalent).

Keying: 50-pin Header at one end has polarizing key to prevent improper installation.

Schematic and Physical Attributes: See Drawing 4501-552.

Shipping Weight: 1.0 pound (0.5Kg) packaged.

TERMINATION PANEL: MODEL 5025-552

Type: Termination Panel For AVME9630/9660 Boards

Application: To connect field I/O signals to the Industrial I/O Pack (IP). *Termination Panel*: Acromag Part 4001-040 (Phoenix Contact Type FLKM 50). The 5025-552 termination panel facilitates the connection of up to 50 field I/O signals and connects to the AVME9630/9660 3U/6U or APC8610 non-intelligent carrier boards (A-D connectors only) via a flat ribbon cable (Model 5025-550-x or 5025-551-x). The A-D connectors on the carrier board connect the field I/O signals to the P2 connector on each of the Industrial I/O Pack modules. Field signals are accessed via screw terminal strips. The terminal strip markings on the termination panel (1-50) correspond to P2 (pins 1-50) on the Industrial I/O Pack (IP). Each Industrial I/O Pack (IP) has its own unique P2 pin assignments. Refer to the IP module manual for correct wiring connections to the termination panel.

Schematic and Physical Attributes: See Drawing 4501-464.

Field Wiring: 50-position terminal blocks with screw clamps. Wire range 12 to 26 AWG.

Connections to AVME9630/9660 or APC8610: P1, 50-pin male header with strain relief ejectors. Use Acromag 5025-550-x or 5025-551-x cable to connect panel to VME board. Keep cable as short as possible to reduce noise and power loss.

Mounting: Termination panel is snapped on the DIN mounting rail. Printed Circuit Board: Military grade FR-4 epoxy glass circuit board, 0.063 inches thick.

Operating Temperature: -40°C to +100°C.

Storage Temperature: -40°C to +100°C.

Shipping Weight : 1.25 pounds (0.6kg) packaged.

TRANSITION MODULE: MODEL TRANS-GP

Type: Transition module for AVME9630/9660 boards.

Application: To repeat field I/O signals of IP modules A through D for rear exit from VME card cages. This module is available for use in card cages which provide rear exit for I/O connections via transition modules (transition modules can only be used in card cages specifically designed for them). It is a double-height (6U), single-slot module with front panel hardware adhering to the VMEbus mechanical dimensions, except for shorter printed circuit board depth. Connects to Acromag termination panel 5025-552 from the rear of the card cage, and to AVME9630/9660 boards within card cage, via flat 50-pin ribbon cable (cable Model 5025-550-X or 5025-551-X).

Schematic and Physical Attributes: See Drawing 4501-465.

Field Wiring: 100-pin header (male) connectors (3M 3433-D303 or equivalent) employing long ejector latches and 30 micron gold in the mating area (per MIL-G-45204, Type II, Grade C). Connects to Acromag termination panel 5025-552 from the rear of the card cage via flat 50-pin ribbon cable (cable Model 5025-550-X or 5025-551-X).

Connections to AVME9630/9660: 50-pin header (male) connectors (3M 3433-1302 or equivalent) employing long ejector latches and 30 micron gold in the mating area (per MIL-G-45204, Type II, Grade C). Connects to AVME9630/9660 boards within the card cage via flat 50-pin ribbon cable (cable Model 5025-550-X or 5025-551-X).

Mounting: Transition module is inserted into a 6U-size, single-width slot at the rear of the VMEbus card cage.

Printed Circuit Board: Six-layer, military-grade FR-4 epoxy glass circuit board, 0.063 inches thick.

Operating Temperature: -40°C to +85°C.

Storage Temperature: -55°C to +105°C.

Shipping Weight: 1.25 pounds (0.6Kg) packaged.

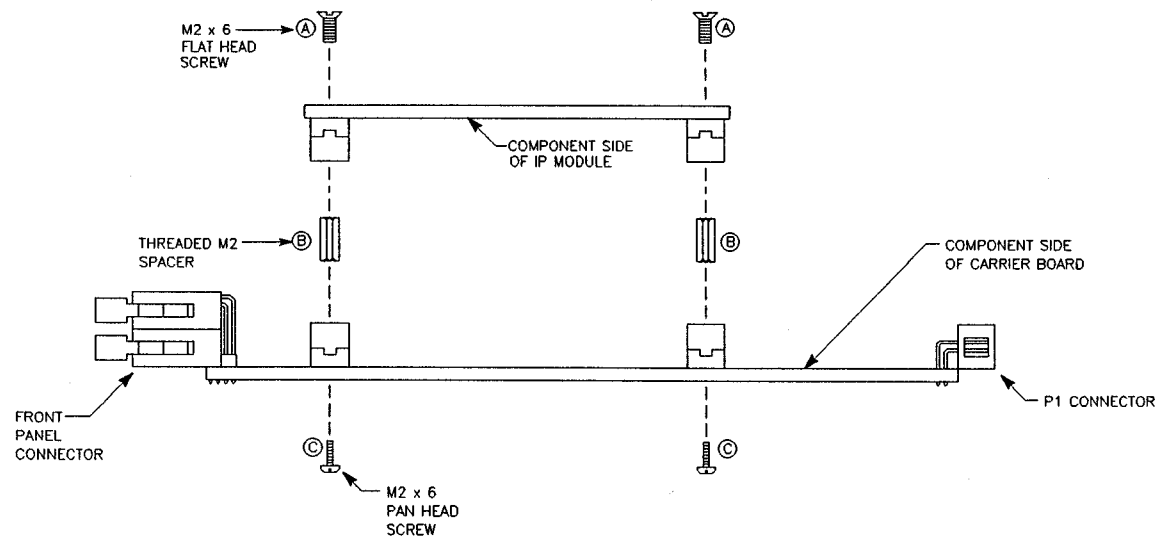

ASSEMBLY PROCEDURE:

1. THREADED SPACERS ARE PROVIDED IN TWO DIFFERENT LENGTHS. THE SHORTER LENGTH IS FOR USE WITH AVME 9630/9660 CARRIER BOARDS (SHOWN). CHECK YOUR CARRIER BOARD TO DETERMINE ITS REQUIREMENTS. MOUNTING HARDWARE PROVIDED MAY NOT BE COMPATIBLE WITH ALL TYPES OF CARRIER BOARDS.
2. INSERT FLAT HEAD SCREWS (ITEM A) THROUGH SOLDER SIDE OF IP MODULE AND INTO HEX SPACERS (ITEM B) AND TIGHTEN (4 PLACES) UNTIL HEX SPACER IS COMPLETELY SEATED.
3. CAREFULLY ALIGN IP MODULE TO CARRIER BOARD AND PRESS TOGETHER UNTIL CONNECTORS AND SPACERS ARE SEATED.
4. INSERT PAN HEAD SCREWS (ITEM C) THROUGH SOLDER SIDE OF CARRIER BOARD AND INTO HEX SPACERS (ITEM B) AND TIGHTEN (4 PLACES).

IP MODULE TO CARRIER BOARD MECHANICAL ASSEMBLY

Acromag <small>WINDMILL MICH.</small>		20 JUL 94	B	040811	TAV	JGV	BC
		21 DEC 93	A		TAV	JGV	BC
TITLE		DATE	REV	ENH	DR	ENG	CLP
IP MECHANICAL ASSEMBLY							
D	SERIES	IP	1 of 1	DOC NO.	4501-434	B	

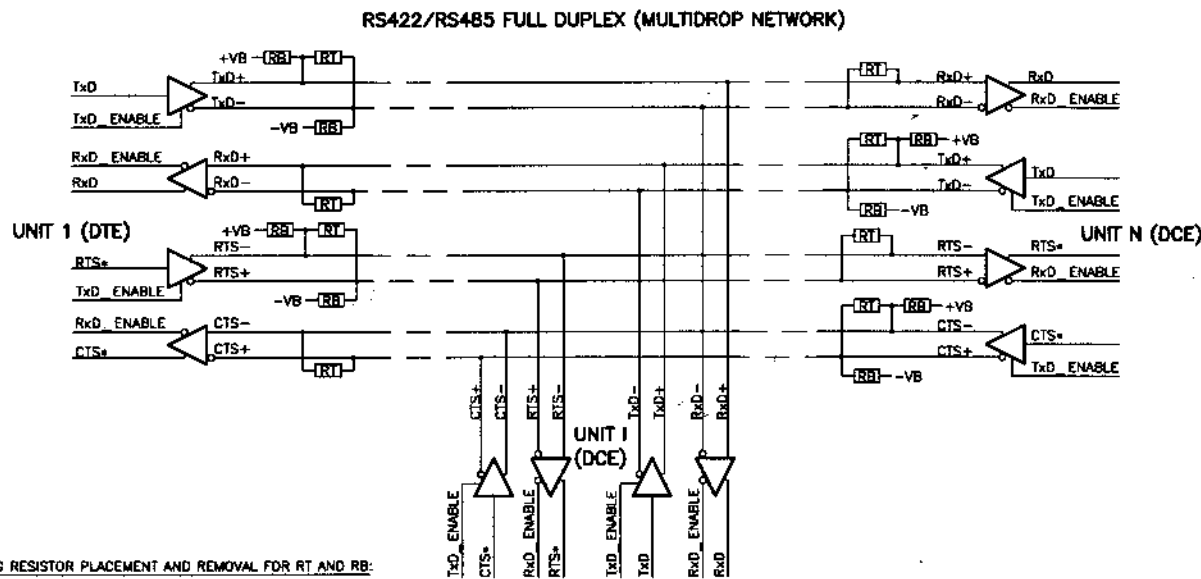
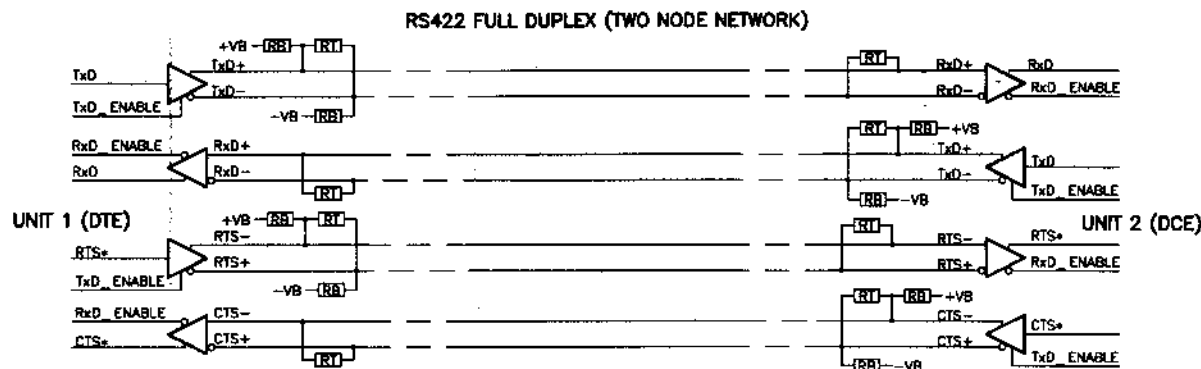

NOTES CONCERNING RESISTOR PLACEMENT AND REMOVAL FOR RT AND RB:

1. ALL TRANSMITTING AND RECEIVING CHANNELS MAY HAVE TERMINATING RESISTORS (RT) AT BOTH ENDS OF THE NETWORK. THE IP501 HAS THESE RESISTORS (120 OHM) INSTALLED IN SOCKETS AND THEY MAY BE REMOVED AS REQUIRED.
2. THERE MUST BE AT MOST, ONE SET OF BIAS RESISTORS ASSOCIATED WITH EACH PAIR OF SIGNAL WIRES TO KEEP THE NETWORK FROM FLOATING WHEN NO UNITS ARE TRANSMITTING.
3. THE TxD AND RTS LINES SOURCED FROM A PORT CAN BE PERMANENTLY ENABLED VIA SOFTWARE. IF SO, THE NETWORK BIAS AND TERMINATION RESISTORS ASSOCIATED WITH EACH PAIR OF SIGNAL WIRES WILL NOT BE NEEDED. THESE RESISTORS ARE INSTALLED IN SOCKETS AND CAN BE REMOVED IF THESE DRIVERS ARE ALWAYS ENABLED.
4. THE IDLE STATE OF THE TxD & RxD DATA PAIRS ARE HIGH ON TxD+ & RxD+. THIS CORRESPONDS TO A MARK (1) ON THE DATA LINE. THE RS232 DATA TRANSMISSION LINE ALSO IDLES AT A MARK (1) ON THE DATA LINE, BUT THIS IS A LOW LEVEL ON THE TRANSMISSION LINE DUE TO THE INVERTING NATURE OF THE DRIVERS.
5. THE IDLE STATE OF THE RTS & CTS TRANSMISSION PAIRS IS THAT THESE CONTROL LINES ARE DEASSERTED (OFF). THIS IS THE SAME AS RS232. RS232 CONTROL LINES ARE ASSERTED (ON) AS A HIGH LEVEL IN THE CABLE. RTS+ AND CTS+ ARE ALSO ASSERTED (ON) AS A HIGH LEVEL IN THE CABLE. THIS IS ACCOMPLISHED BY INVERTING THE DRIVER & RECEIVER OUTPUT/INPUT LINES.

A POSSIBLE TRANSMISSION SEQUENCE FOR COMMUNICATION CHANNELS ON AN RS422/485, FULL-DUPLEX, TWO NODE NETWORK:

1. THE DTE NODE WAITS FOR CTS+ TO BE DEASSERTED. IF NO NODES ARE DRIVING RTS+ OR CTS+, THEN THE BIAS RESISTORS ON THE NETWORK KEEP RTS+ AND CTS+ DEASSERTED (THE IDLE STATE). THE DTE/DCE MAY PERMANENTLY ENABLE ITS RTS+/CTS+ TRANSMITTER AND DRIVE THE PAIRS TO THE DEASSERTED STATE (IN WHICH CASE, THE NETWORK BIAS RESISTORS ARE NOT NEEDED). THE MODEL IP501 HAS THESE RESISTORS INSTALLED IN SOCKETS AND THEY MAY BE REMOVED AS NECESSARY.
2. THE DTE NODE INDICATES ITS INTENTION TO TRANSMIT BY ASSERTING RTS+. THE DCE NODE RECEIVES THIS SIGNAL AND THEN ASSERTS CTS+ TO INDICATE READINESS TO THE DTE.
3. THE DTE MAINTAINS THE ASSERTION OF RTS+ AND TRANSMITS ITS DATA. DATA IS TRANSMITTED VIA THE TxD+ AND TxD- LINES.
4. TO ACHIEVE FULL-DUPLEX, THE DCE MAY ECHO WHAT WAS SENT OR PROVIDE A DIFFERENT APPROPRIATE RESPONSE AT THE SAME TIME IT IS RECEIVING FROM THE DTE.
5. WHEN TRANSMISSION IS COMPLETE, THE DTE DEASSERTS RTS+, AND THE DCE DEASSERTS CTS+.

A POSSIBLE TRANSMISSION SEQUENCE FOR COMMUNICATION CHANNELS ON AN RS485 FULL-DUPLEX NETWORK:

1. THE DTE NODE WAITS FOR CTS+ TO BE DEASSERTED. IF NO NODES ARE DRIVING CTS+, THEN THE BIAS RESISTORS ON THE NETWORK KEEP CTS+ DEASSERTED (THE IDLE STATE).
2. THE DTE NODE ASSERTS RTS+. THIS ASSERTS RTS+ AT ALL DCE NODES.
3. WITH MORE THAN TWO NODES ON THE NETWORK, IT WOULD NOT MAKE SENSE FOR THE DTE NODE TO WAIT FOR A CTS+ ASSERTION BEFORE TRANSMITTING, BECAUSE MORE THAN ONE RECEIVING NODE WOULD HAVE TO ASSERT THEIR CTS+ SIGNAL TO SATISFY THE DTE NODE. THUS, THE DTE NODE MAINTAINS THE ASSERTION OF RTS+ AND TRANSMITS ITS DATA. DATA IS TRANSMITTED VIA THE TxD+ AND TxD- LINES.
4. TO ACHIEVE FULL-DUPLEX, A SINGLE DCE NODE FOR WHICH THE MESSAGE WAS INTENDED MAY PROVIDE AN APPROPRIATE RESPONSE AT THE SAME TIME IT IS RECEIVING. ASSERTING CTS+ COULD BE USED AS A MECHANISM TO INDICATE THIS TRANSMISSION. DATA IS SENT BY THE DCE UNIT OVER THE RxD+ AND RxD- LINES.
5. WHEN DTE TRANSMISSION IS COMPLETE, THE DTE NODE RELEASES RTS+. THIS CAUSES RTS+ TO MOVE TO THE DEASSERTED OR IDLE STATE.
6. WHEN DCE TRANSMISSION IS COMPLETE, THE DCE NODE RELEASES CTS+. THIS CAUSES CTS+ TO MOVE TO THE DEASSERTED OR IDLE STATE.

Acromag WIKOM WICH		REV. 02	DATE	BY	CHKD	APP'D
TITLE		IP501 RS-422/485 INTERFACE DIAGRAM				
D	REV. NO.	IP501	1 of 1	DOC. NO.	4501-554	

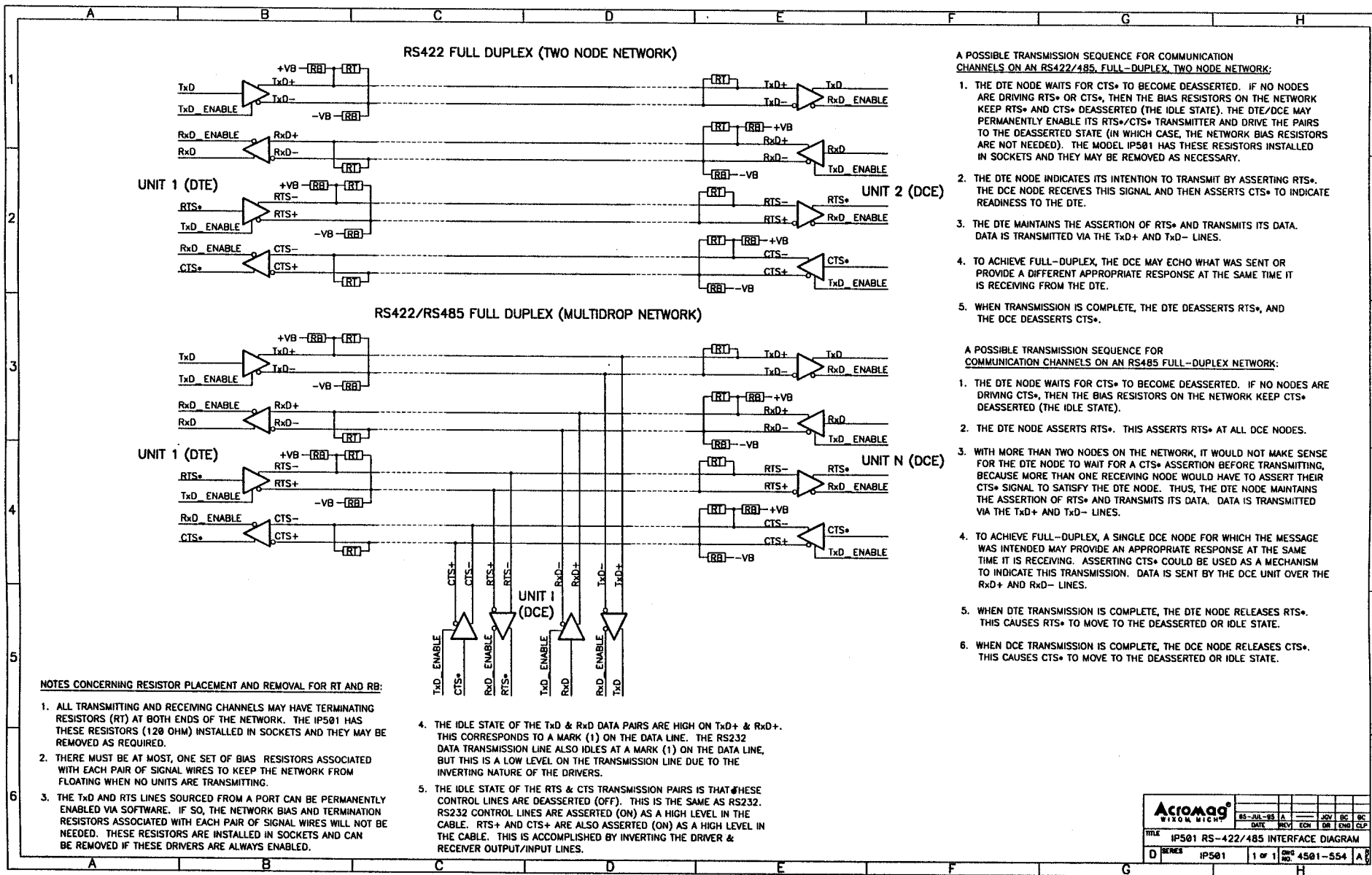

- A POSSIBLE TRANSMISSION SEQUENCE FOR COMMUNICATION CHANNELS ON AN RS422/485, FULL-DUPLEX, TWO NODE NETWORK:**
1. THE DTE NODE WAITS FOR CTS* TO BECOME DEASSERTED. IF NO NODES ARE DRIVING RTS* OR CTS*, THEN THE BIAS RESISTORS ON THE NETWORK KEEP RTS* AND CTS* DEASSERTED (THE IDLE STATE). THE DTE/DCE MAY PERMANENTLY ENABLE ITS RTS*/CTS* TRANSMITTER AND DRIVE THE PAIRS TO THE DEASSERTED STATE (IN WHICH CASE, THE NETWORK BIAS RESISTORS ARE NOT NEEDED). THE MODEL IP501 HAS THESE RESISTORS INSTALLED IN SOCKETS AND THEY MAY BE REMOVED AS NECESSARY.
 2. THE DTE NODE INDICATES ITS INTENTION TO TRANSMIT BY ASSERTING RTS* . THE DCE NODE RECEIVES THIS SIGNAL AND THEN ASSERTS CTS* TO INDICATE READINESS TO THE DTE.
 3. THE DTE MAINTAINS THE ASSERTION OF RTS* AND TRANSMITS ITS DATA. DATA IS TRANSMITTED VIA THE TxD+ AND TxD- LINES.
 4. TO ACHIEVE FULL-DUPLEX, THE DCE MAY ECHO WHAT WAS SENT OR PROVIDE A DIFFERENT APPROPRIATE RESPONSE AT THE SAME TIME IT IS RECEIVING FROM THE DTE.
 5. WHEN TRANSMISSION IS COMPLETE, THE DTE DEASSERTS RTS* , AND THE DCE DEASSERTS CTS* .

- A POSSIBLE TRANSMISSION SEQUENCE FOR COMMUNICATION CHANNELS ON AN RS485 FULL-DUPLEX NETWORK:**
1. THE DTE NODE WAITS FOR CTS* TO BECOME DEASSERTED. IF NO NODES ARE DRIVING CTS*, THEN THE BIAS RESISTORS ON THE NETWORK KEEP CTS* DEASSERTED (THE IDLE STATE).
 2. THE DTE NODE ASSERTS RTS* . THIS ASSERTS RTS* AT ALL DCE NODES.
 3. WITH MORE THAN TWO NODES ON THE NETWORK, IT WOULD NOT MAKE SENSE FOR THE DTE NODE TO WAIT FOR A CTS* ASSERTION BEFORE TRANSMITTING, BECAUSE MORE THAN ONE RECEIVING NODE WOULD HAVE TO ASSERT THEIR CTS* SIGNAL TO SATISFY THE DTE NODE. THUS, THE DTE NODE MAINTAINS THE ASSERTION OF RTS* AND TRANSMITS ITS DATA. DATA IS TRANSMITTED VIA THE TxD+ AND TxD- LINES.
 4. TO ACHIEVE FULL-DUPLEX, A SINGLE DCE NODE FOR WHICH THE MESSAGE WAS INTENDED MAY PROVIDE AN APPROPRIATE RESPONSE AT THE SAME TIME IT IS RECEIVING. ASSERTING CTS* COULD BE USED AS A MECHANISM TO INDICATE THIS TRANSMISSION. DATA IS SENT BY THE DCE UNIT OVER THE RxD+ AND RxD- LINES.
 5. WHEN DTE TRANSMISSION IS COMPLETE, THE DTE NODE RELEASES RTS* . THIS CAUSES RTS* TO MOVE TO THE DEASSERTED OR IDLE STATE.
 6. WHEN DCE TRANSMISSION IS COMPLETE, THE DCE NODE RELEASES CTS* . THIS CAUSES CTS* TO MOVE TO THE DEASSERTED OR IDLE STATE.

NOTES CONCERNING RESISTOR PLACEMENT AND REMOVAL FOR RT AND RB:

1. ALL TRANSMITTING AND RECEIVING CHANNELS MAY HAVE TERMINATING RESISTORS (RT) AT BOTH ENDS OF THE NETWORK. THE IP501 HAS THESE RESISTORS (120 OHM) INSTALLED IN SOCKETS AND THEY MAY BE REMOVED AS REQUIRED.
2. THERE MUST BE AT MOST, ONE SET OF BIAS RESISTORS ASSOCIATED WITH EACH PAIR OF SIGNAL WIRES TO KEEP THE NETWORK FROM FLOATING WHEN NO UNITS ARE TRANSMITTING.
3. THE TxD AND RTS LINES SOURCED FROM A PORT CAN BE PERMANENTLY ENABLED VIA SOFTWARE. IF SO, THE NETWORK BIAS AND TERMINATION RESISTORS ASSOCIATED WITH EACH PAIR OF SIGNAL WIRES WILL NOT BE NEEDED. THESE RESISTORS ARE INSTALLED IN SOCKETS AND CAN BE REMOVED IF THESE DRIVERS ARE ALWAYS ENABLED.
4. THE IDLE STATE OF THE TxD & RxD DATA PAIRS ARE HIGH ON TxD+ & RxD+. THIS CORRESPONDS TO A MARK (1) ON THE DATA LINE. THE RS232 DATA TRANSMISSION LINE ALSO IDLES AT A MARK (1) ON THE DATA LINE, BUT THIS IS A LOW LEVEL ON THE TRANSMISSION LINE DUE TO THE INVERTING NATURE OF THE DRIVERS.
5. THE IDLE STATE OF THE RTS & CTS TRANSMISSION PAIRS IS THAT THESE CONTROL LINES ARE DEASSERTED (OFF). THIS IS THE SAME AS RS232. RS232 CONTROL BIAS LINES ARE ASSERTED (ON) AS A HIGH LEVEL IN THE CABLE. RTS+ AND CTS+ ARE ALSO ASSERTED (ON) AS A HIGH LEVEL IN THE CABLE. THIS IS ACCOMPLISHED BY INVERTING THE DRIVER & RECEIVER OUTPUT/INPUT LINES.

Acromag <small>BYRON BUCH</small>		85-JUL-85	A						
		DATE	REV	ECH	DR	END	CLP		
TITLE IP501 RS-422/485 INTERFACE DIAGRAM									
D	SERIES	IP501	1	OF	1	OR	NO	4501-554	A

IP501 TERMINATION AND BIAS SIP RESISTOR LOCATION DRAWING FOR REMOVAL AND REPLACEMENT WHERE REQUIRED (SEE DRAWING 4501-554)

MODEL IP501 COMPONENT SIDE PARTIAL VIEW

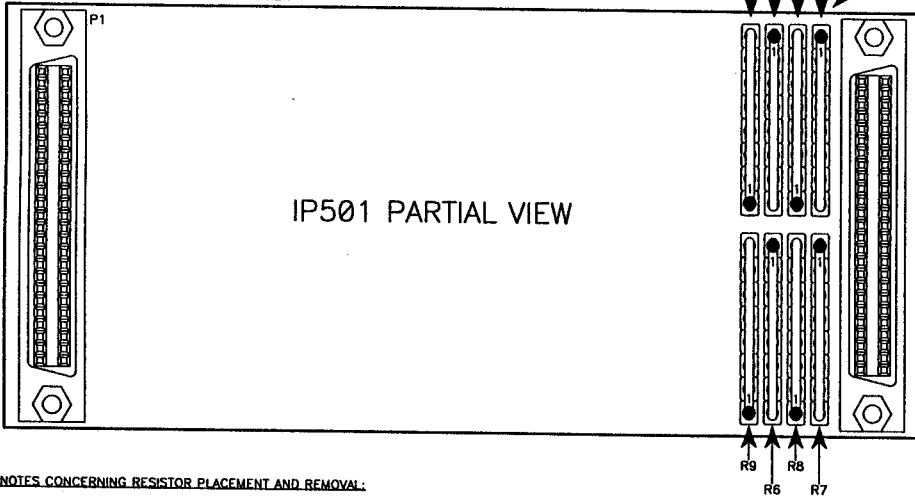

RESISTOR SIPs ARE GROUPS OF FOUR ISOLATED RESISTORS (8 PINS). PIN 1 POSITION IS IDENTIFIED BY A DOT.
RESISTOR SIPs ARE MOUNTED IN SOCKETS AND CAN BE REMOVED IF REQUIRED.

RESISTOR SIPs ARE DIVIDED AS SHOWN

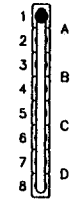

MODULE IS SHIPPED WITH ALL SIP RESISTORS INSTALLED

NOTES CONCERNING RESISTOR PLACEMENT AND REMOVAL:

- ALL TRANSMITTING AND RECEIVING CHANNELS MAY HAVE TERMINATING RESISTORS (RT) AT BOTH ENDS OF THE NETWORK. THE IP501 HAS USER-REMOVEABLE PLUG-IN SIP TERMINATION RESISTORS (120 OHM).
- THERE MUST BE AT MOST, ONE SET OF BIAS RESISTORS ASSOCIATED WITH EACH PAIR OF SIGNAL WIRES TO KEEP THE NETWORK FROM FLOATING WHEN NO UNITS ARE TRANSMITTING.
- THE TxD AND RTS LINES SOURCED FROM A PORT CAN BE PERMANENTLY ENABLED VIA SOFTWARE. IF SO, THE NETWORK BIAS AND TERMINATION RESISTORS ASSOCIATED WITH EACH PAIR OF SIGNAL WIRES WILL NOT BE NEEDED. THESE RESISTORS ARE INSTALLED IN SOCKETS AND CAN BE REMOVED IF THESE DRIVERS ARE ALWAYS ENABLED.
- THE IDLE STATE OF THE TxD & RxD DATA PAIRS ARE HIGH ON TxD+, & RxD+ THIS CORRESPONDS TO A MARK (1) ON THE DATA LINE. THE RS232 DATA TRANSMISSION LINE ALSO IDLES AT A MARK (1) ON THE DATA LINE, BUT THIS IS A LOW LEVEL ON THE TRANSMISSION LINE DUE TO THE INVERTING NATURE OF THE DRIVERS.
- THE IDLE STATE OF THE RTS & CTS TRANSMISSION PAIRS IS THAT THESE CONTROL LINES ARE DEASSERTED (OFF). THIS IS THE SAME AS RS232. RS232 CONTROL LINES ARE ASSERTED (ON) AS A HIGH LEVEL IN THE CABLE. RTS+ AND CTS+ ARE ALSO ASSERTED (ON) AS A HIGH LEVEL IN THE CABLE. THIS IS ACCOMPLISHED BY INVERTING THE DRIVER & RECEIVER OUTPUT/INPUT LINES.

RESISTOR IDENTIFICATION

SIP	VALUE	FUNCTION	PORT
R6:A	120 OHM	RxD-A TERMINATION	PORT A
R6:B	120 OHM	CTS-A TERMINATION	PORT A
R6:C	120 OHM	RxD-B TERMINATION	PORT B
R6:D	120 OHM	CTS-B TERMINATION	PORT B
R12:A	120 OHM	RxD-C TERMINATION	PORT C
R12:B	120 OHM	CTS-C TERMINATION	PORT C
R12:C	120 OHM	RxD-D TERMINATION	PORT D
R12:D	120 OHM	CTS-D TERMINATION	PORT D
R9:A	120 OHM	TxD-A TERMINATION	PORT A
R9:B	120 OHM	RTS-A TERMINATION	PORT A
R9:C	120 OHM	TxD-B TERMINATION	PORT B
R9:D	120 OHM	RTS-B TERMINATION	PORT B
R11:A	120 OHM	TxD-C TERMINATION	PORT C
R11:B	120 OHM	RTS-C TERMINATION	PORT C
R11:C	120 OHM	TxD-D TERMINATION	PORT D
R11:D	120 OHM	RTS-D TERMINATION	PORT D
R8:A	560 OHM	TxD-A+ BIAS +5V	PORT A
R8:B	560 OHM	TxD-A- BIAS GND	PORT A
R8:C	560 OHM	RTS-A+ BIAS GND	PORT A
R8:D	560 OHM	RTS-A- BIAS +5V	PORT A
R7:A	560 OHM	RTS-B- BIAS +5V	PORT B
R7:B	560 OHM	RTS-B+ BIAS GND	PORT B
R7:C	560 OHM	TxD-B- BIAS GND	PORT B
R7:D	560 OHM	TxD-B+ BIAS +5V	PORT B
R10:A	560 OHM	TxD-C+ BIAS +5V	PORT C
R10:B	560 OHM	TxD-C- BIAS GND	PORT C
R10:C	560 OHM	RTS-C+ BIAS GND	PORT C
R10:D	560 OHM	RTS-C- BIAS +5V	PORT C
R13:A	560 OHM	RTS-D- BIAS +5V	PORT D
R13:B	560 OHM	RTS-D+ BIAS GND	PORT D
R13:C	560 OHM	TxD-D- BIAS GND	PORT D
R13:D	560 OHM	TxD-D+ BIAS +5V	PORT D

Acromag WILSON, MICH		30-JAN-88	A	BC	BC	BC
DATE		REV	ECN	DR	ENG	CLP
TITLE IP501 TERMINATION/BIAS RESISTOR LOCATION						
D	REVISED	IP501	1 of 1	DRW NO	4501-555	AP

IP501 BLOCK DIAGRAM

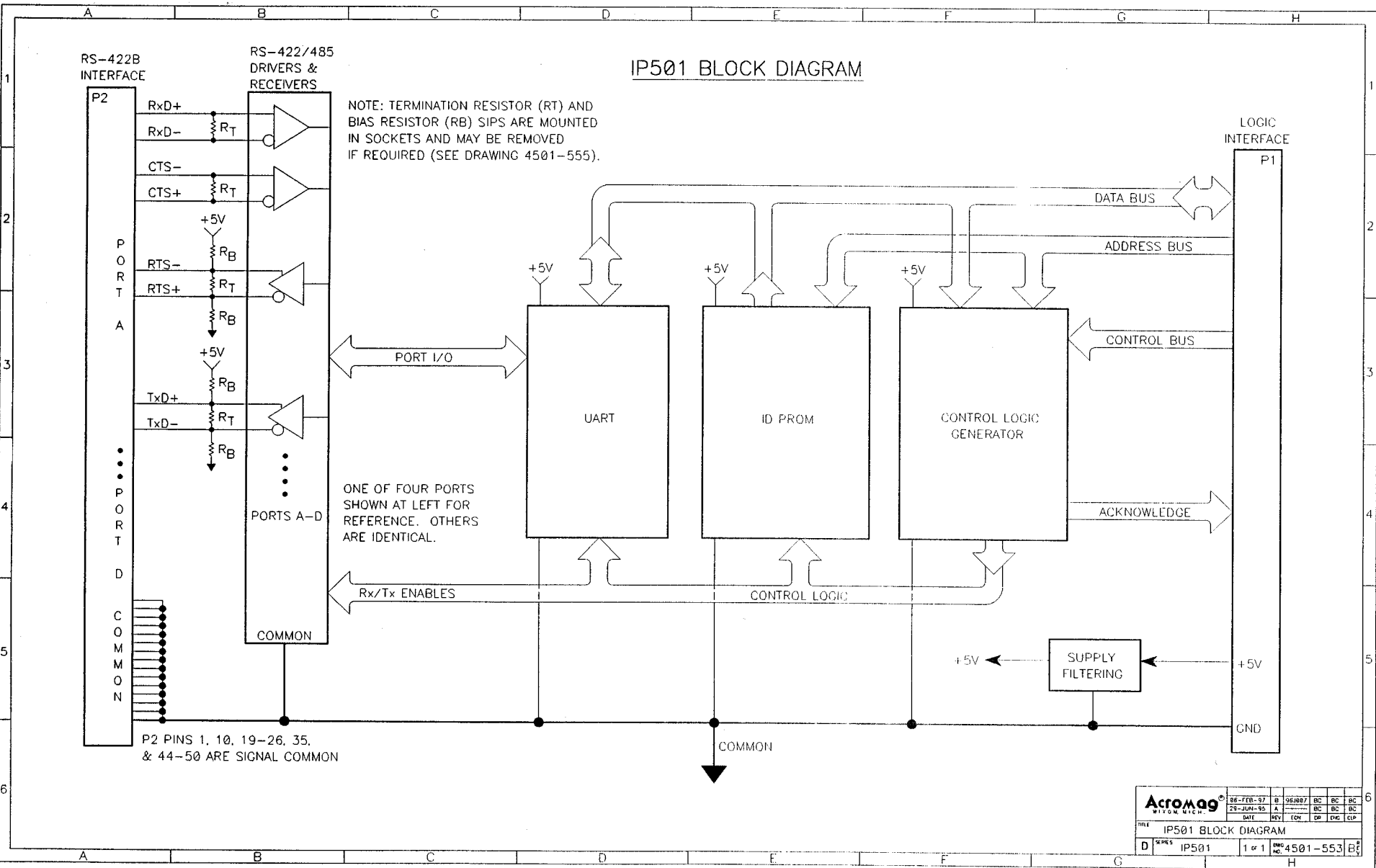

Acromag WILSON, MICH.		06-FEB-97	B	06/007	0C	0C	0C
DATE		29-JUN-95	A		0C	0C	0C
REV					0P	0C	0P
D	SERIES	IP501	1	1	4501-553 B		

1.) RS-422 TxD AND RxD DATA LINES (FULL DUPLEX)

2.) RS-422 HANDSHAKE LINES (RTS/CTS)

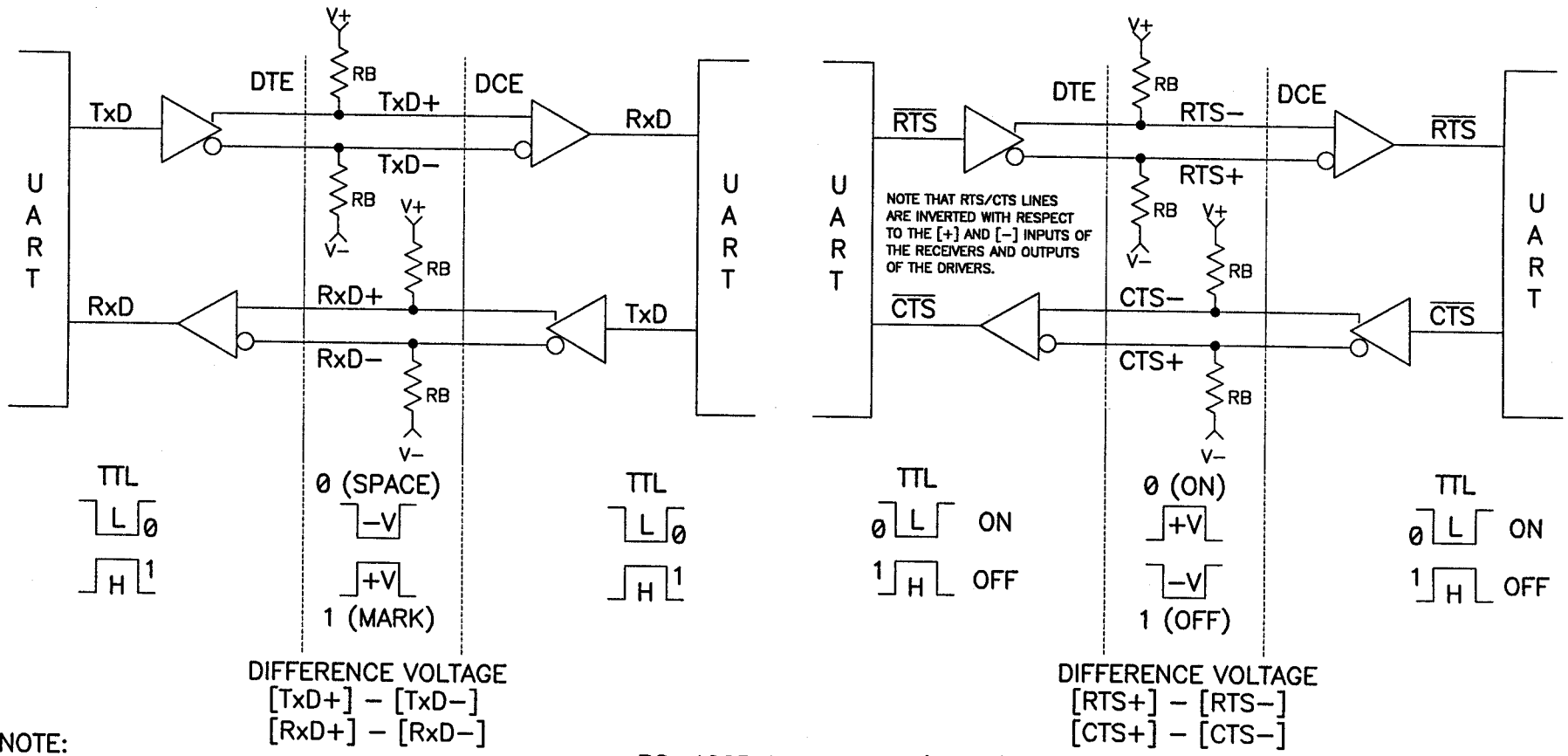

NOTE:

- RS-422 IS CONSIDERED A BALANCED (DIFFERENTIAL) TRANSMISSION STANDARD BECAUSE THE VOLTAGE OF ONE SIGNAL LINE IS TAKEN WITH RESPECT TO ANOTHER TO DETERMINE THE SIGNAL LEVEL.
- NOTE THAT ONLY ONE SET OF NETWORK BIAS RESISTORS SHOULD EXIST PER NETWORK WIRE PAIR. MODEL IP501 BOARDS HAVE THESE RESISTORS INSTALLED IN SOCKETS ON THE BOARD.

RS-422B CONNECTOR (IP501)

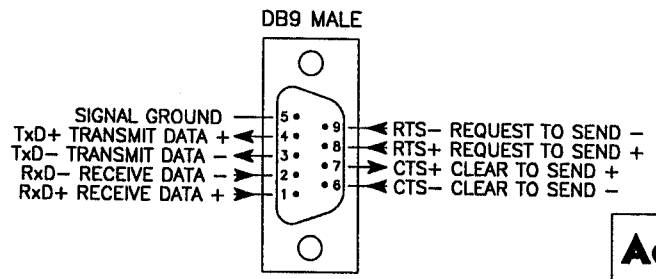

SEE ACROMAG CABLE MODEL 5029-943

Acromag WIXOM, MICH.		17 AUG 95	A		BC	BC	BC
TITLE UNDERSTANDING RS-422 INTERFACE LEVELS		DATE	REV	ECN	DR	ENG	CLP
C	SERIES IP501	1 OF 1	DWG NO. 4501-570		A		

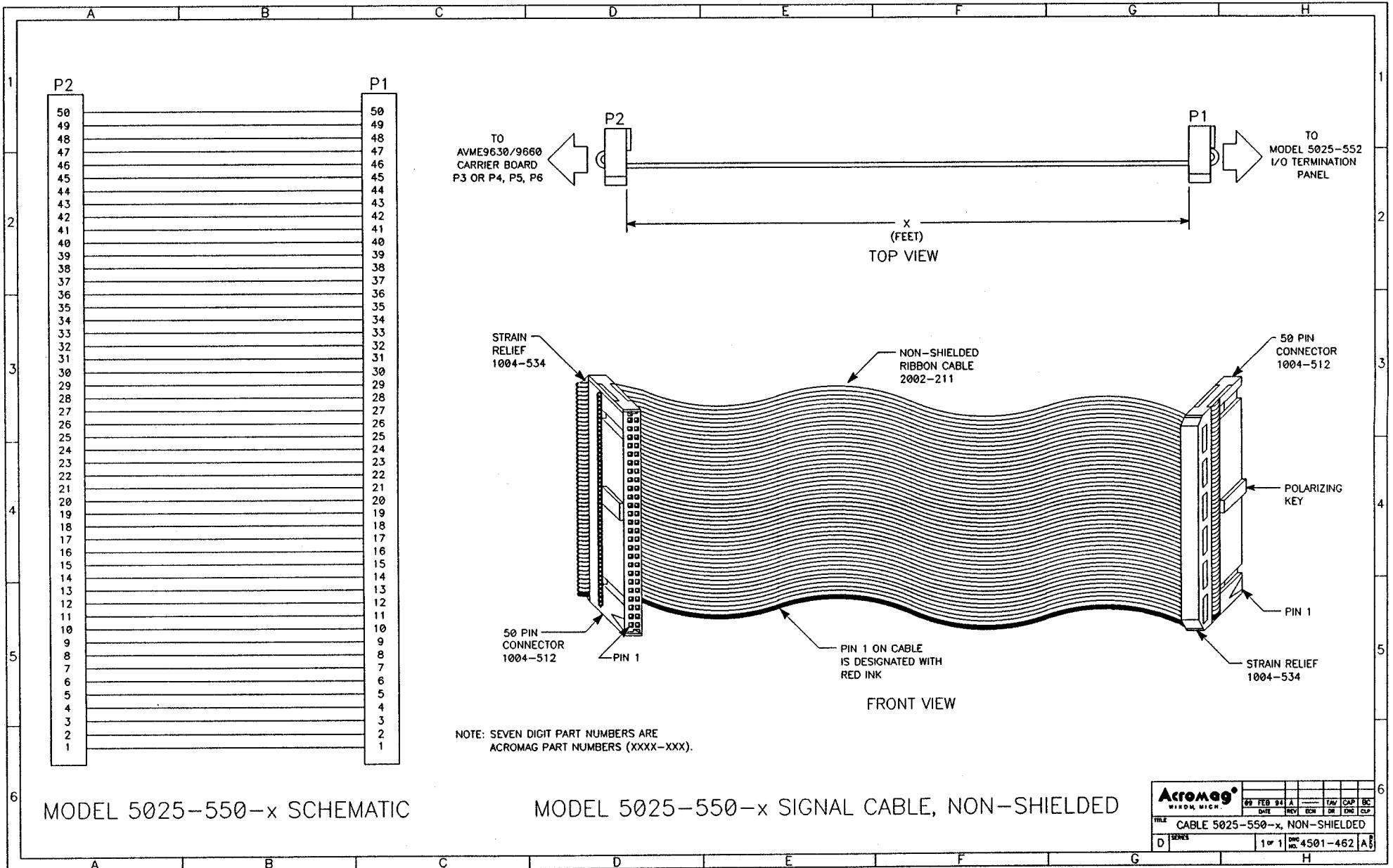

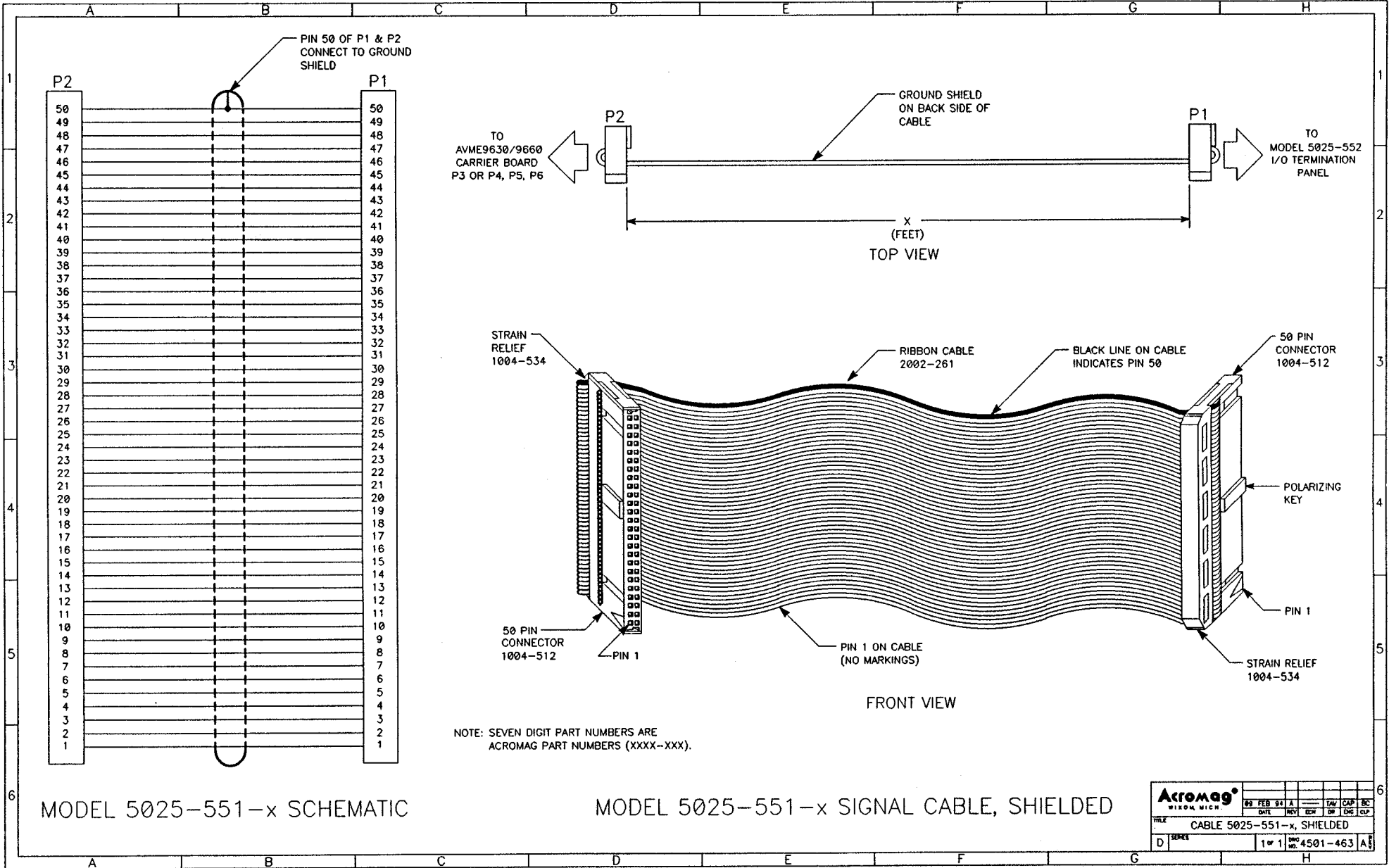

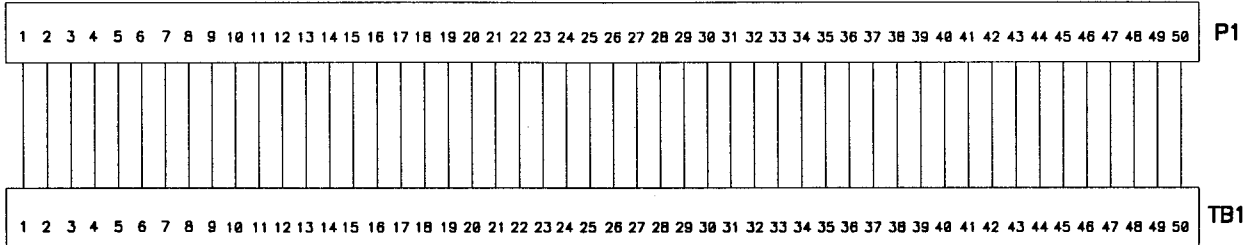

MODEL 5025-552 TERMINATION PANEL SCHEMATIC

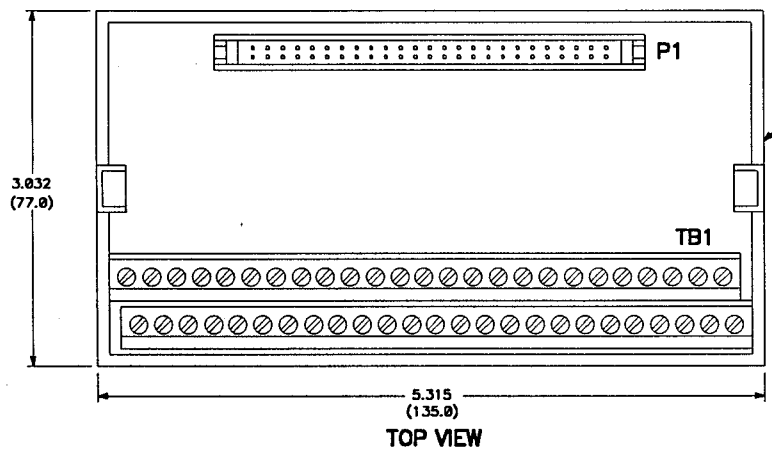

TOP VIEW

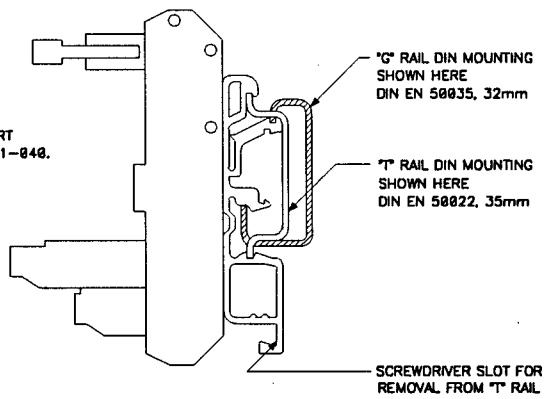

SIDE VIEW

TERMINATION
PANEL
ACROMAG PART
NUMBER 4001-040.

"G" RAIL DIN MOUNTING
SHOWN HERE
DIN EN 50035, 32mm

"T" RAIL DIN MOUNTING
SHOWN HERE
DIN EN 50022, 35mm

SCREWDRIVER SLOT FOR
REMOVAL FROM "T" RAIL

NOTES:
DIMENSIONS ARE IN INCHES (MILLIMETERS).
TOLERANCE: ± 0.020 (± 0.5).

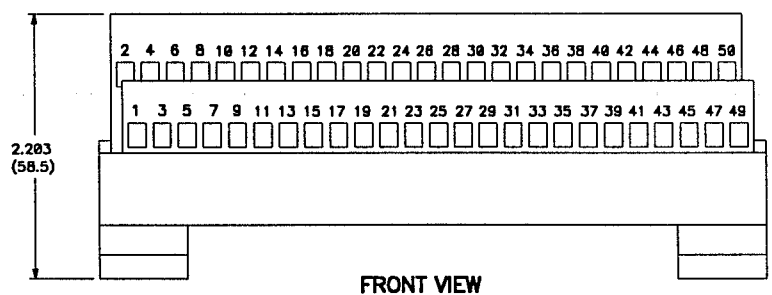

FRONT VIEW

MODEL 5025-552 TERMINATION PANEL

Acromag®						
WIXOM, MICH.		09 FEB 94	A	TAV	CAP	BC
		DATE	REV	ECN	DR	ENG
TITLE MODEL 5025-552 TERMINATION PANEL						
D	SERIES	1 of 1	DWG NO.	4501-464	A	REV

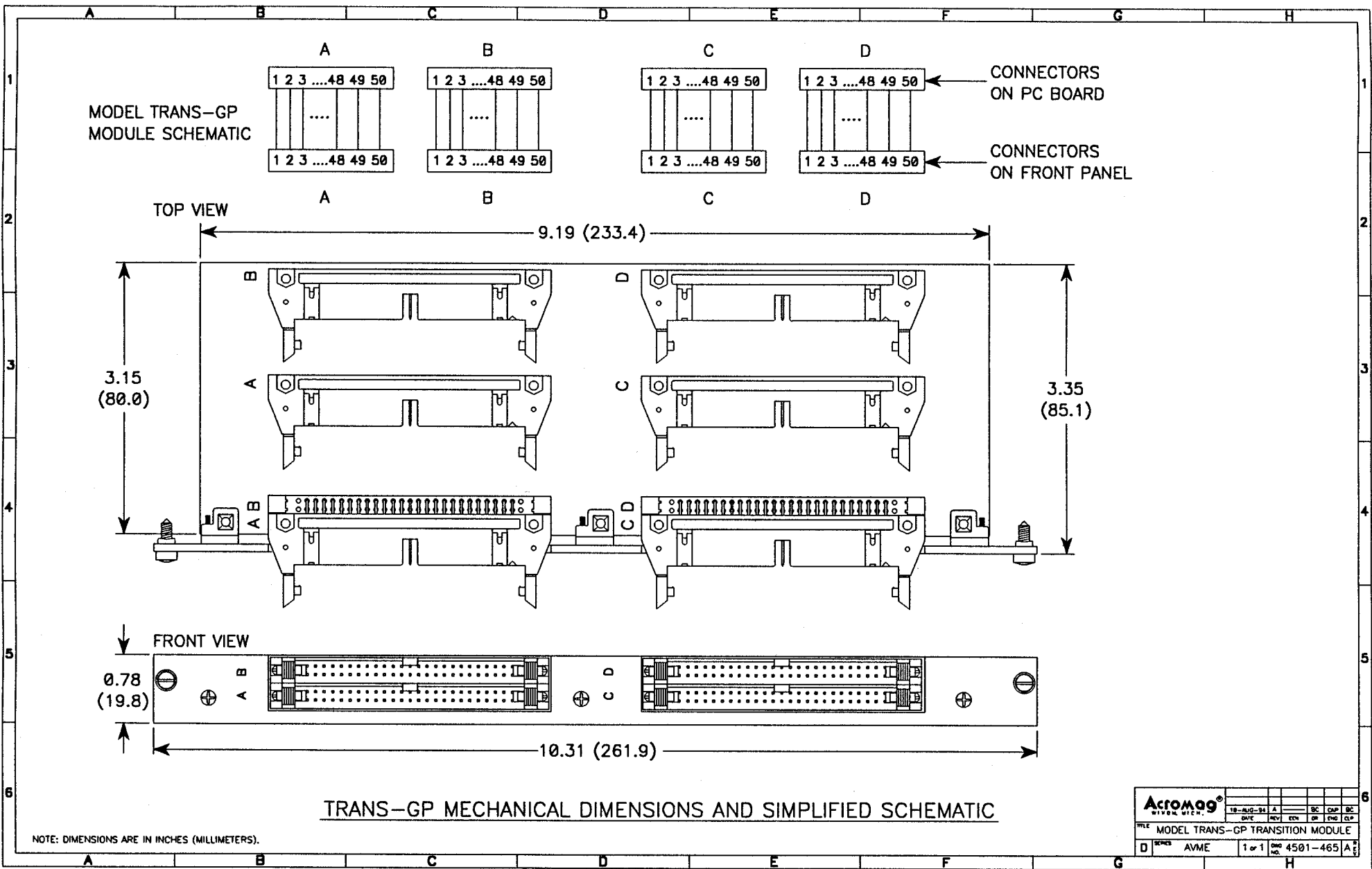

Acromag WILSON TECH.		18-820-34	A	DC	CLP	DC
DATE	REV	EN	OR	END	CLP	
TITLE: MODEL TRANS-GP TRANSITION MODULE						
D	REVISED	AVME	1 of 1	DRW NO.	4501-465	A