

USB Isolation and Industrial I/O

Why You Need USB Isolation





Contents

About USB	3
Advantages of USB	3
What is Isolation?	3
Methods of Isolation	4
Do I need USB Isolation?	4
Why do I need USB Isolation?	4
Example of an Industrial USB Isolator	6
About Acromag	7
Because We Know I/O	7

[See Acromag's USB Isolator](#)

Be sure to visit Acromag on the web at www.acromag.com.

This information is provided as a service to our customers and to others interested in learning more about USB Isolation. Acromag assumes no responsibility for any errors that may occur in this document, and makes no commitment to update, or keep this information current.



About USB

The USB port has become the most popular method for connecting virtually anything to a computer such as simple flash drives to complex industrial I/O equipment. Most computers built in the last 5 to 10 years have at least 1 USB port with newer computers having upwards of 6 or more. For most home users, having an isolated USB connection is not an issue, however for things such as industrial/remote I/O, data acquisition, IT or medical equipment, isolating a USB connection can be a necessity. This paper will look at the advantages of using USB, what isolation means, types of isolation, when and why USB connections should be isolated.

Advantages of USB

There are many reasons USB has gained in popularity over tried and true predecessors like serial, GPIB and parallel ports. Some of those reasons are:

- **Plug and Play** – Once the driver software is loaded onto the computer, you simply have to plug the USB device into a USB port and it is ready to use. Depending on the USB model, the operating system may already have drivers for your device built into it. Gone are the days of finding available addresses and IRQ's.
- **It's fast** – Computers/devices supporting USB 1.1 can transfer data up to 12 MBits/Sec and USB 2.0 can reach speeds of 480 MBits/Sec.
- **Inexpensive/Expandable** – USB hubs and cabling are relatively inexpensive which makes setting up the needed infrastructure very palatable. Through the use of hubs and cables, up to 127 USB devices can be connected to one USB port.
- **Noise Immunity** – For applications like industrial or remote I/O, using USB devices moves the sensitive data conversion circuitry out of the noisy PC environment and places it up to 5 meters away at the other end of the USB cable.
- **Hot Swappable** – USB devices can be connected and disconnected without first turning the power off.

What is Isolation?

Quite simply, isolation is achieved by removing any direct electrical connection between two devices or portions of a circuit, but having them work as if they were electrically connected. Isolation is generally rated by how high a low current AC voltage can be set before there is arcing across the isolation barrier. Some common isolation terminologies are:

- **Isolation Rating** – This is the transient overvoltage that an isolation barrier can withstand. Usually expressed in terms of AC voltage, some common ratings are 500 Vrms at 1 minute for industrial equipment, 2500 Vrms (IEC 60950-1) at 1 minute for IT equipment and 5000 Vrms (IEC 60601-1) at 1 minute for medical equipment.
- **Working Voltage** – This is the continuous voltage that can be applied across an isolation barrier for the life of the device without breaking down. Like the isolation rating, it is usually expressed as an AC voltage.
- **Reinforced Isolation** – Usually required for medical systems, this the isolation rating equals two separate isolation barriers. In medical systems, this means the isolation barrier would have to withstand a short duration of 10,000 Vrms.
- **Creepage** – This is the shortest distance between two lines on a surface layer of a PCB, on either side of the isolation barrier.
- **Clearance** – This is the shortest air gap between two lines on a PCB.



Methods of Isolation

There are several methods of isolation. The method used depends largely on what exactly is being isolated, the bandwidth of any signals being isolated and whether or not power must be transferred between the two sides of the isolation barrier. Some of the common methods are:

- **Optoisolators** – These work by combining a LED and a phototransistor in the same package. As the LED emits light, the phototransistor will change states, these are well suited for isolating digital signals, but cannot transfer power across the barrier.
- **Transformers** – These work by using magnetic coupling. Transformers are very good for passing power and fast switching signals across the isolation barrier.
- **Differential Capacitor Coupling (DCC)** – This method makes use of a capacitors ability to pass AC signals while blocking DC. DCC can be used for high speed digital data.

Do I need USB Isolation?

Whether or not you need to isolate your USB device from the computer is dependant on the application. For something like connecting a flash drive to a computer, the answer is almost always no, however if it's medical equipment being connected to the computer, the answer is almost always yes. If you're connecting industrial/remote I/O equipment to your computer, there is no easy answer, you must evaluate the environment in which the device(s) will be installed. Things to consider are whether or not the sensors or device could be subjected to ESD (Electrostatic Discharge), Lightning, Power Surges, Ground Loops, differing ground potentials and/or EMI/RFI (Electromagnetic Interference/Radio Frequency Interference), if the answer to any of these is yes, then you need to isolate the USB connection.

Why do I need USB Isolation?

In the case of ESD, Lightning and Power Surges, having a non-isolated USB connection can permit dangerous voltages to travel from the sensor, through the USB device, through the cable and into the computer and possibly into other peripherals connected to the computer. Best case is the computer shuts down and needs to be restarted, worst case is complete system failure with many hours or days of down time for device repair or replacement. Even if the transient is small enough to not damage your equipment, the data can contain large errors, especially when using single ended measurement techniques.

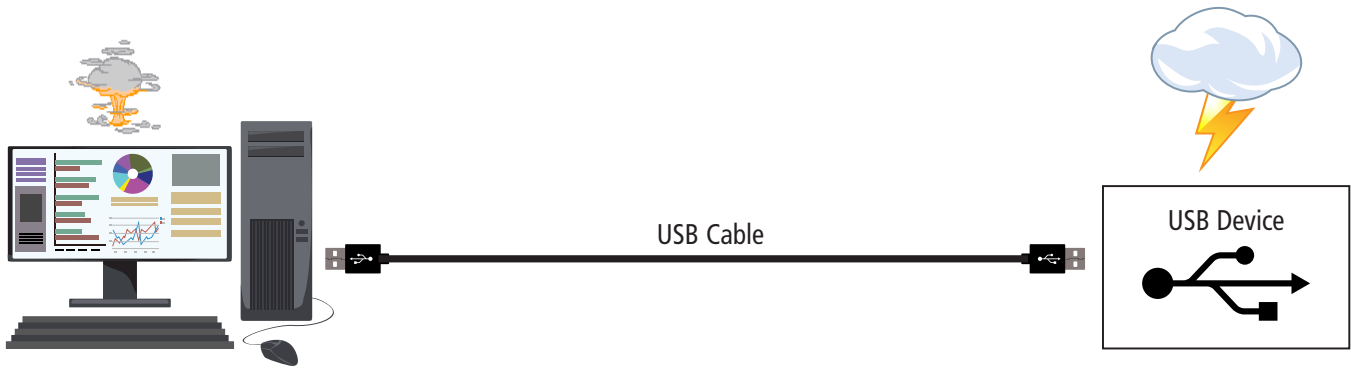

Figure 1 – USB device connection without isolation.

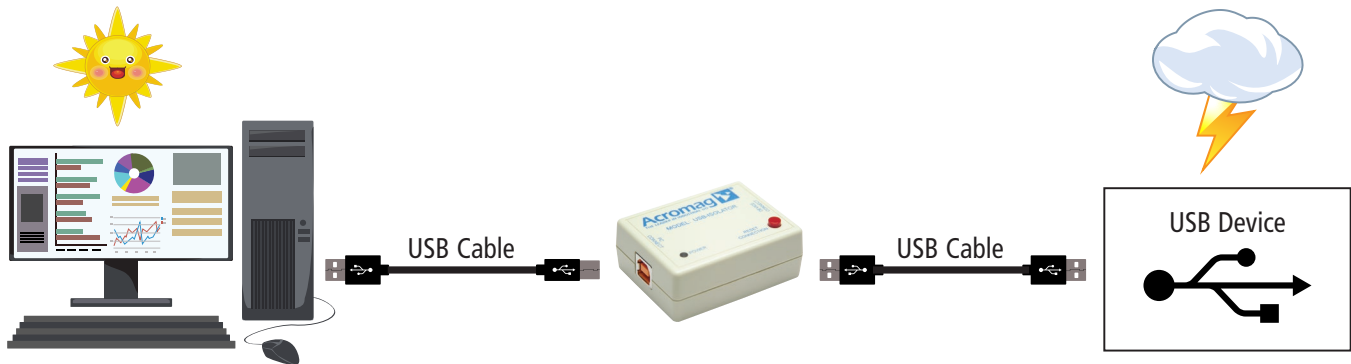

Figure 2: USB device with an Acromag USB-Isolator installed.

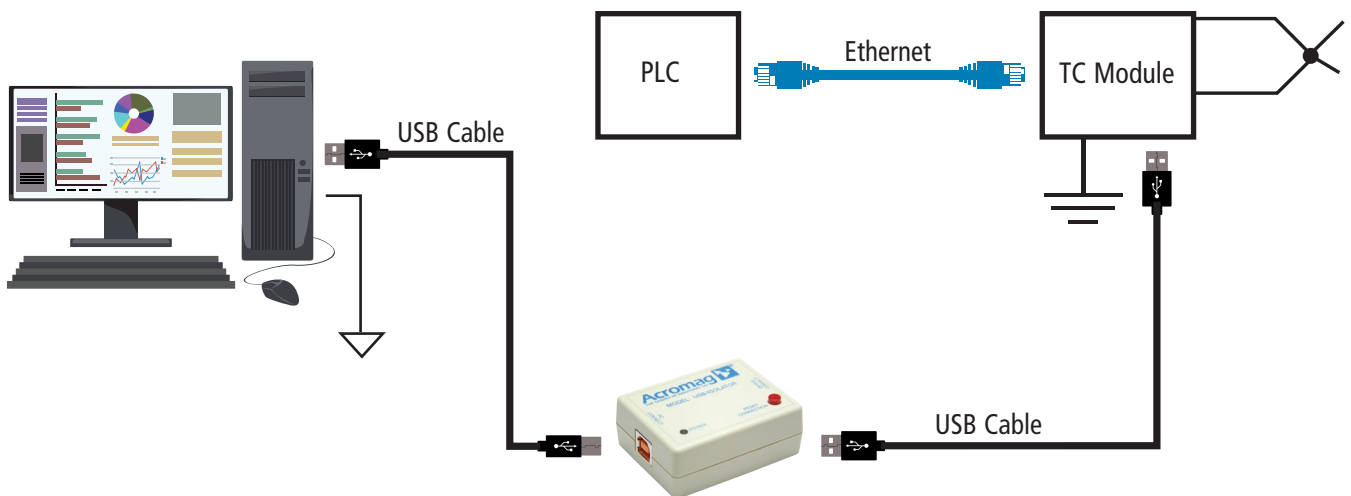

Figure 3: Differing grounds is another situation where USB isolation should be used.



With ground loops or EMI/RFI present, the risk of equipment damage or complete failure is still possible, but less likely. The big issue with these conditions are measurement errors. Some of the errors can be minimized by using differential measurement techniques, but the best way to eliminate the problem is to isolate.

When dealing with industrial/remote I/O, the only time using a non-isolated connection is recommended is when the environment is completely safe from all of the issues mentioned before.

Isolating your USB connection also has other benefits. In some types of in-circuit testing, you can use single ended measurement techniques where only differential would have worked otherwise, it also allows you to use techniques such as 4-wire Kelvin, guarding and back driving.

Example of an Industrial USB Isolator

While some industrial measurement devices have USB isolation built in, many do not. A USB-Isolator, such as the one below, can provide USB isolation when needed. Here are some features to look for:



Case Material: Plastic non-conductive, UL94 rating or better.

Package: Small and rugged.

Connectors: High retention USB Type A (x 1) and USB Type B (x 1) connectors with minimum withdrawal force of 15 Newton's.

Data Rate: Selectable full-speed 12Mbps(Default) or low-speed 1.5Mbps.

Transient Protection: Transient Voltage Suppressors applied at both the transmit and receive channels.

LED – For power indication and diagnostics.

Filtering – Common mode filtering on all data lines.

Output Protection: Short circuit protection with auto-retry.

Safety Approvals: CE, FCC, UL/cUL

Environmental

Power Supply: Standard 5VDC power provided from the USB host computer up to 120mA of current.

Current Limit: Isolator is equipped with 200mA input limit to isolator (~137mA out). Once limit is reached, power will open and retry until current draw is less than 200mA.

Isolation: USB network circuits are isolated from each other for working voltages up to 250VAC, or 354V DC off DC power ground, on continuous basis (will withstand 1500VAC dielectric strength test for one minute without breakdown). Complies with test requirements of ANSI/ISA-82.01-1988 for voltage rating specified.

Operating Temperature: -40°C to +70°C (-40°F to +158°F).



About Acromag

Acromag is a multi-million-dollar international corporation that combines more than [60 years of process monitoring and control experience](#) with a solid background in high-tech computer design.

We are focused on developing industrial I/O solutions that provide the best long-term value in the industry. A complete line of industrial I/O products including process instruments, signal conditioning equipment, data acquisition boards, distributed I/O modules, and network communication devices are available. Industries served include manufacturing, water services, power generation, mining, defense, and transportation.

Acromag I/O is ideal for a broad range of monitoring and control operations where controllers communicate with instrumentation on the plant floor or in the field.

[Click here](#) to receive Acromag's monthly eNewsletter.

Because We Know I/O

Doing business with Acromag means you can count on receiving dependable value when using our products. We guarantee to meet or exceed published product performance specifications and offer you exceptional personal service with a real person within one business day.