

**USB Programmable, DIN Rail Mount
Thin Transmitter**

**Model TT335-0700
RTD/Resistance Input
Universal Current & Voltage Output**

USER'S MANUAL



**ACROMAG INCORPORATED
30765 South Wixom Road
Wixom, MI 48393-2417 U.S.A.**

**Tel: (248) 295-0880
Fax: (248) 624-9234
email: sales@acromag.com**

Copyright 2018, Acromag, Inc., Printed in the USA.
Data and specifications are subject to change without notice.

8500997M

Table of Contents

GETTING STARTED

DESCRIPTION..... 4

- Key Features4
- Application4
- Mechanical Dimensions5
- DIN Rail Mounting & Removal.....5

ELECTRICAL CONNECTIONS 6

- Sensor Input Connections7
- Output Connections.....9
- Power Connections10
- Optional Bus & Redundant Power Connections 11
- Earth Ground Connections12
- USB Connections.....13

CONFIGURATION SOFTWARE..... 14

- Quick Overview – Android14
- Quick Overview – Windows15

OPERATION STEP-BY-STEP 17

- Connections.....17
- Configuration.....19
- Calibration (Optional)21
- RTD Resistance versus Temperature23

BLOCK DIAGRAM 24

- How It Works.....24

TROUBLESHOOTING 25

- Diagnostics Table25
- Service & Repair Assistance26

ACCESSORIES..... 27

- Software Interface Package.....27
- USB Isolator.....27
- USB A-B Cable.....27
- USB A-mini B Cable27
- USB OTG Cable28
- DIN Rail Bus Connector Kit28
- End Stops.....28

SPECIFICATIONS 29

- Model Number29
- Input29
- Output.....31
- USB Interface.....33
- Power.....33
- Enclosure & Physical34
- Environmental34
- Agency Approvals35
- Reliability Prediction.....35
- Configuration Controls.....35

REVISION HISTORY 37

All trademarks are the property of their respective owners.

IMPORTANT SAFETY CONSIDERATIONS

It is very important for the user to consider the possible adverse effects of power, wiring, component, sensor, or software failures in designing any type of control or monitoring system. This is especially important where economic property loss or human life is involved. It is important that the user employ satisfactory overall system design. It is agreed between the Buyer and Acromag, that this is the Buyer's responsibility.

The information of this manual may change without notice. Acromag, Inc. makes no warranty of any kind with regard to this material, including, but not limited to, the implied warranties of merchantability and fitness for a particular purpose. Further, Acromag, Inc. assumes no responsibility for any errors that may appear in this manual and makes no commitment to update, or keep current, the information contained in this manual. No part of this manual may be copied or reproduced in any form without the prior written consent of Acromag, Inc.

GETTING STARTED

DESCRIPTION

Symbols on equipment:



Means “Refer to User’s Manual (this manual) for additional information”.

The TT335-0700 is an ANSI/ISA Type 4 transmitter designed to interface with RTDs (Resistance Temperature Detector), or resistive elements, isolate the input signal, and modulate a DC current or DC voltage signal at its output. The transmitter provides RTD sensor excitation, linearization, lead-wire compensation, and lead break or sensor burnout detection. Configuration is performed using software and a USB connection to Windows-based PC’s (Windows XP and later versions only).

Key Features

- Fully configurable using Windows software via USB.
- Thin 17.5mm wide enclosure for high-density DIN-rail mounting.
- High measurement accuracy and linearity.
- Pt100, Pt200, Pt500, Pt1000, Copper, and Nickel type RTDs supported.
- 25Ω, 450Ω, 2250Ω, and 4500Ω resistive ranges also supported.
- Connects to two-wire, three-wire, or four-wire sensors.
- Four-wire configuration eliminates error associated with lead-wire resistance.
- Up or down-scale lead-break/burnout detection.
- RTD inputs are linearized with respect to temperature.
- Supports Celsius, Fahrenheit, and Kelvin temperature units.
- Adjustable input range and selectable output ranges.
- Input, output, and power circuits are fully isolated from each other.
- Universal output for ±10V, 0-10V, ±5V, 0-5V, ±20mA, 0-20mA, and 4-20mA.
- Output drives DC current or DC voltage without rewiring.
- Normal or reverse acting output.
- Variable input filter adjustment.
- Wide-range DC power input form 12–32VDC.
- Wide ambient temperature operation.
- Thoroughly tested and hardened for harsh environments.
- CE Approved.
- FCC Conformity Class B.
- UL/cUL Class I, Division 2 Approved.
- Model TT335-0700 is ATEX/IECEX Certified for Explosive Atmospheres.
 Ⓔ II 3 G Ex ec IIC T4 Gc -40°C ≤ Ta ≤ +80°C
 DEMKO 15 ATEX 1561X IECEx UL 18.0091X

Application

For additional information on these devices and related topics, please visit our web site at www.acromag.com. Also see whitepaper 8500-917: The Basics of Temperature Measurement Using RTDs

The TT335 transmitter is designed for high-density mounting on 35mm T-type DIN rails. Modules may be mounted side-by-side on 0.7 inch (17.5mm) centers. 12–32V DC power is supported via terminals on the module, or optionally via power wired to its DIN-rail bus connector.

This model interfaces with RTD or resistive element inputs and isolates the input signal allowing it to mate with grounded or non-grounded input signals. It provides an output signal linearized to the RTD sensor temperature. Optionally, it can support simple resistance input and drive an output signal linear with sensor resistance.

The universal output signal is isolated from the input and power and will drive current or voltage signals for the ranges $\pm 20\text{mA}$, $0\text{--}20\text{mA}$, $4\text{--}20\text{mA}$, $\pm 10\text{V}$, $0\text{--}10\text{V}$, $\pm 5\text{V}$, and $0\text{--}5\text{V}$. The output of this transmitter is unique in that it can drive either current or voltage under digital control using the same terminals.

Mechanical Dimensions

Modules may be mounted to 35mm "T" type DIN rail (35mm, type EN50022), and side-by-side on 17.5mm (0.7-inch) centers.

NOTE:

IEC Safety Standards may require that this module be mounted within an approved metal enclosure or sub-system, particularly for applications with exposure to voltages greater than or equal to 75VDC or 50VAC.

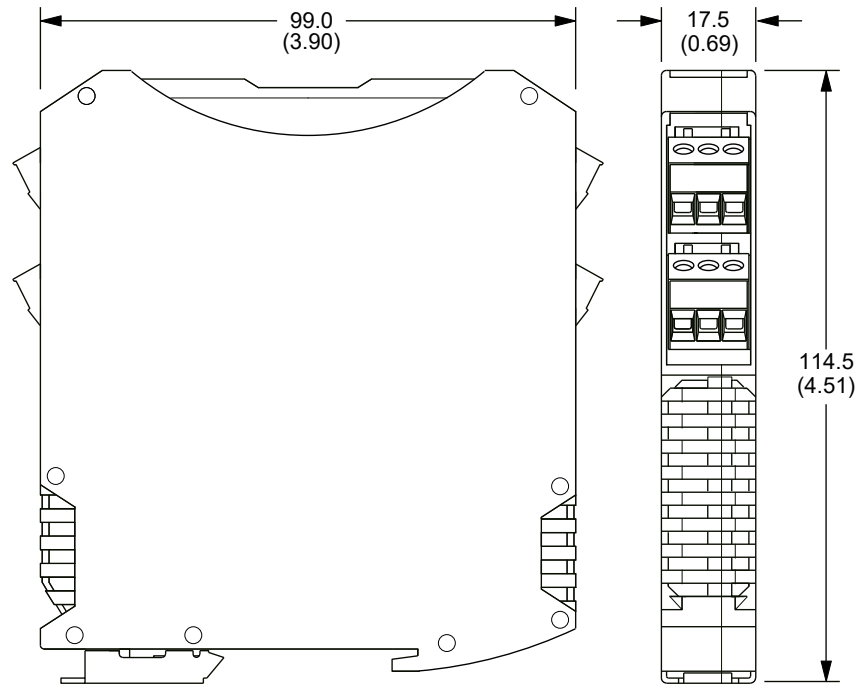

DIMENSIONS ARE IN MILLIMETERS (INCHES)

DIN Rail Mounting & Removal

Refer to the following figure for mounting and removing a module from the DIN rail.

Mounting

A spring loaded DIN clip is located on the input side bottom. The rounded edge of the output side bottom allows the module to tilt upward so that it may be lifted from the rail when prying the spring clip back with a screwdriver. To attach a module to T-type DIN rail, angle the top of the module towards the rail and place the top groove of the module over the upper lip of the DIN rail. Firmly push the module downward towards the rail until it snaps into place.

Removal

To remove a module from the DIN rail, first separate the input terminal blocks from the bottom side of the module to create a clearance to the DIN mounting area. A screwdriver can be used to pry the pluggable terminals out of their sockets. While holding the module in place from above, insert a screwdriver into the lower path of the bottom of the module to the DIN rail clip and use it as a lever to force the DIN rail spring clip down while pulling the bottom of the module outward until it disengages from the rail. Tilt the module upward to lift it from the rail.

TT3XX MODULE DIN RAIL MOUNTING AND REMOVAL

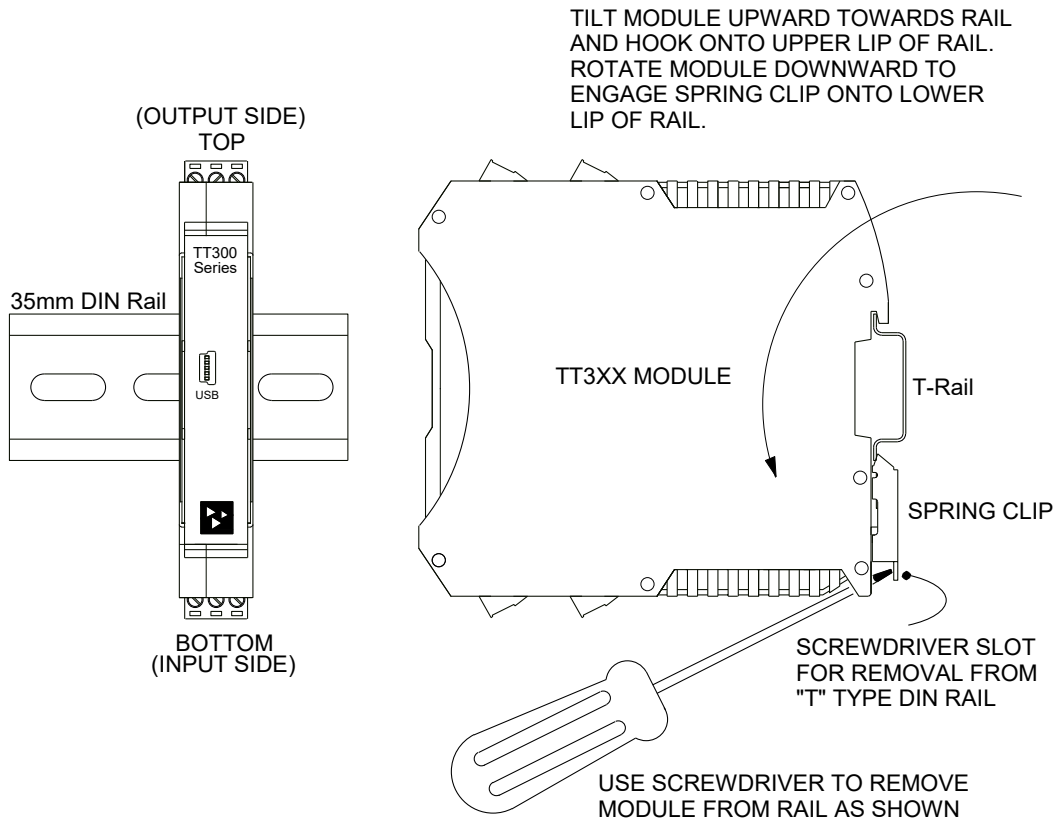

ELECTRICAL CONNECTIONS



WARNING – EXPLOSION HAZARD – Do not disconnect equipment unless power has been removed or the area is known to be non-hazardous.

WARNING – EXPLOSION HAZARD – Substitution of any components may impair suitability for Class I, Division 2.

WARNING – EXPLOSION HAZARD – The area must be known to be non-hazardous before servicing/replacing the unit and before installing.

Wire terminals can accommodate 14–26 AWG (2.08–0.13mm²) solid or stranded wire with a minimum temperature rating of 85°C. Input wiring may be shielded or unshielded type. Ideally, output wires should be twisted pair. Terminals are pluggable and can be removed from their sockets by prying outward from the top with a flat-head screwdriver blade.

Strip back wire insulation 0.25-inch on each lead and insert the wire ends into the cage clamp connector of the terminal block. Use a screwdriver to tighten the screw by turning it in a clockwise direction to secure the wire (0.5-0.6Nm torque). Since common mode voltages can exist on signal wiring, adequate wire insulation should

be used and proper wiring practices followed. As a rule, output wires are normally separated from input wiring for safety, as well as for low noise pickup.

Sensor Input Connections

Sensor wires are connected directly to the transmitter input terminals at the bottom of the transmitter (the spring-loaded DIN clip side), as shown in the connection drawing below.

- **Transmitter input signal is isolated from output.**
- **Three-wire input sensors require jumper:** For three-wire sensors (including resistive elements), a copper jumper wire must be connected between input pins 1 and 4 ([+] and [H]).
- **Two-wire input sensors require jumpers:** For a two-wire sensor (including resistive elements), a copper jumper wire must be connected between input pins 4 and 5 ([-] and [L]) as well as pins 1 and 4 ([+] and [H]).
- **Four-wire configuration eliminates error associated with lead-wire resistance:** A four-wire configuration allows the input sensor to be accurately measured without having to compensate for the resistance of the lead-wires. RTDs are typically measured by passing an excitation current through the RTD element and relating the measured voltage drop across the RTD element with a corresponding temperature. Because the lead-wires to the RTD element have intrinsic resistance, a voltage drop is created in the lead-wires in addition to the voltage drop across the RTD element. By using two dedicated wires to directly measure only the RTD element, the voltage drop created by the resistance of the lead-wires is removed from the measurement altogether.

MODEL TT335-0700 INPUT SENSOR WIRING

SEE FOLLOWING PAGE FOR INPUT SENSOR WIRING DETAILS

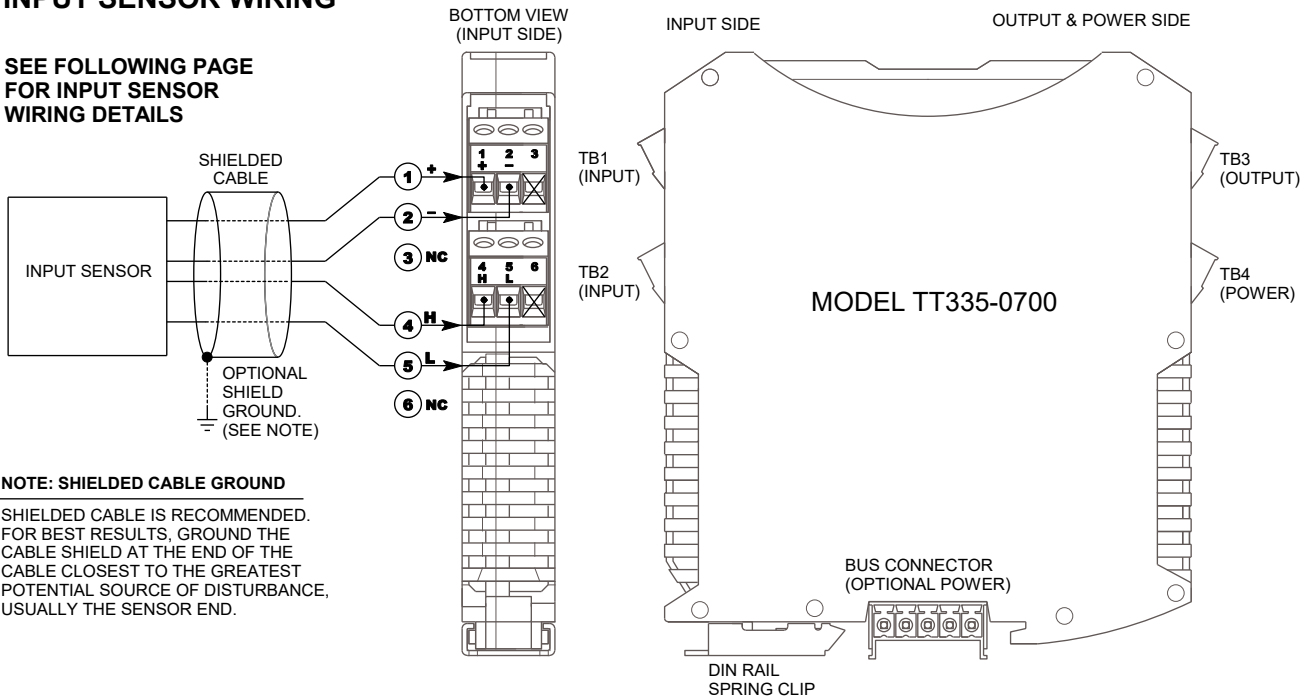

NOTE: SHIELDED CABLE GROUND

SHIELDED CABLE IS RECOMMENDED. FOR BEST RESULTS, GROUND THE CABLE SHIELD AT THE END OF THE CABLE CLOSEST TO THE GREATEST POTENTIAL SOURCE OF DISTURBANCE, USUALLY THE SENSOR END.

Sensor Input Connections

INPUT SENSOR WIRING 4-WIRE RTD

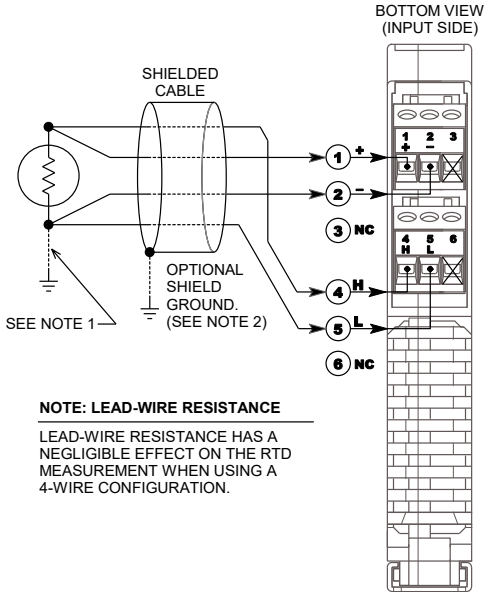

INPUT SENSOR WIRING 3-WIRE RTD

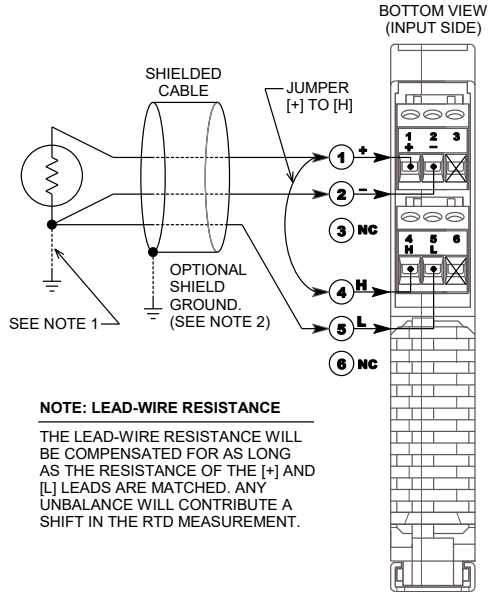

INPUT SENSOR WIRING 2-WIRE RTD

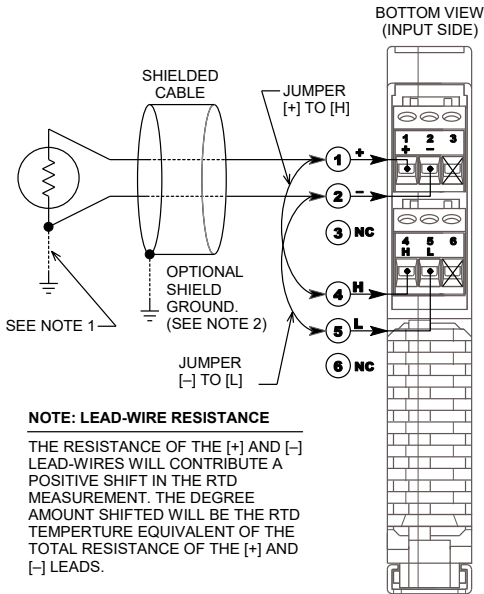

INPUT SENSOR WIRING RESISTANCE DECADE BOX (4-WIRE CONFIGURATION)

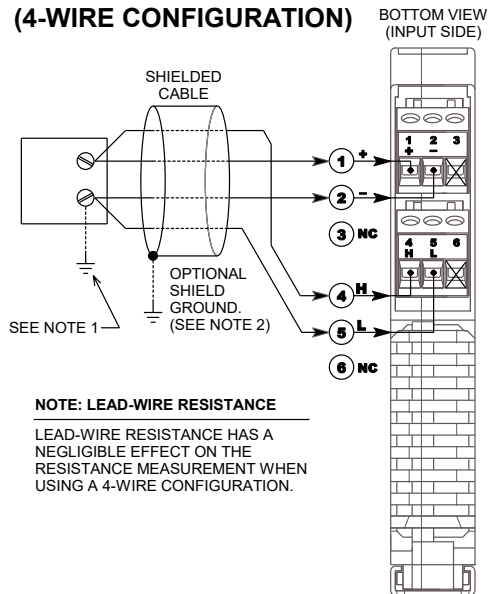

NOTE 1: SENSOR GROUND

THIS GROUND CONNECTION IS RECOMMENDED FOR BEST RESULTS. IF SENSORS ARE INHERENTLY CONNECTED TO GROUND, USE CAUTION AND AVOID MAKING ADDITIONAL GROUND CONNECTIONS WHICH COULD GENERATE GROUND LOOPS AND MEASUREMENT ERRORS. DO NOT GROUND THE INPUT SENSOR IF UNIT IS CONNECTED TO A GROUNDED PC WITHOUT AN USB ISOLATOR.

NOTE 2: SHIELDED CABLE GROUND

SHIELDED CABLE IS RECOMMENDED. FOR BEST RESULTS, GROUND THE CABLE SHIELD AT THE END OF THE CABLE CLOSEST TO THE GREATEST POTENTIAL SOURCE OF DISTURBANCE, USUALLY THE SENSOR END.

Output Connections

(DC Current or Voltage)

NOTE:

This transmitter is an ANSI/ISA Type 4 in which the transmitter's power is isolated from the input and output circuits.

- Output connections are polarized. Current is output from Output+ and returns to Output-. Voltage output is positive at Output+.
- Variations in load resistance have negligible effect on output accuracy, as long as load limits are respected with respect to output type.
- Note the placement of earth ground. The output cable shield and return should ideally be grounded closest to the transmitter. Only one end of the connection should be grounded, never both.

MODEL TT33X-0700 OUTPUT WIRING
OUTPUT WIRED FOR DC CURRENT OR VOLTAGE

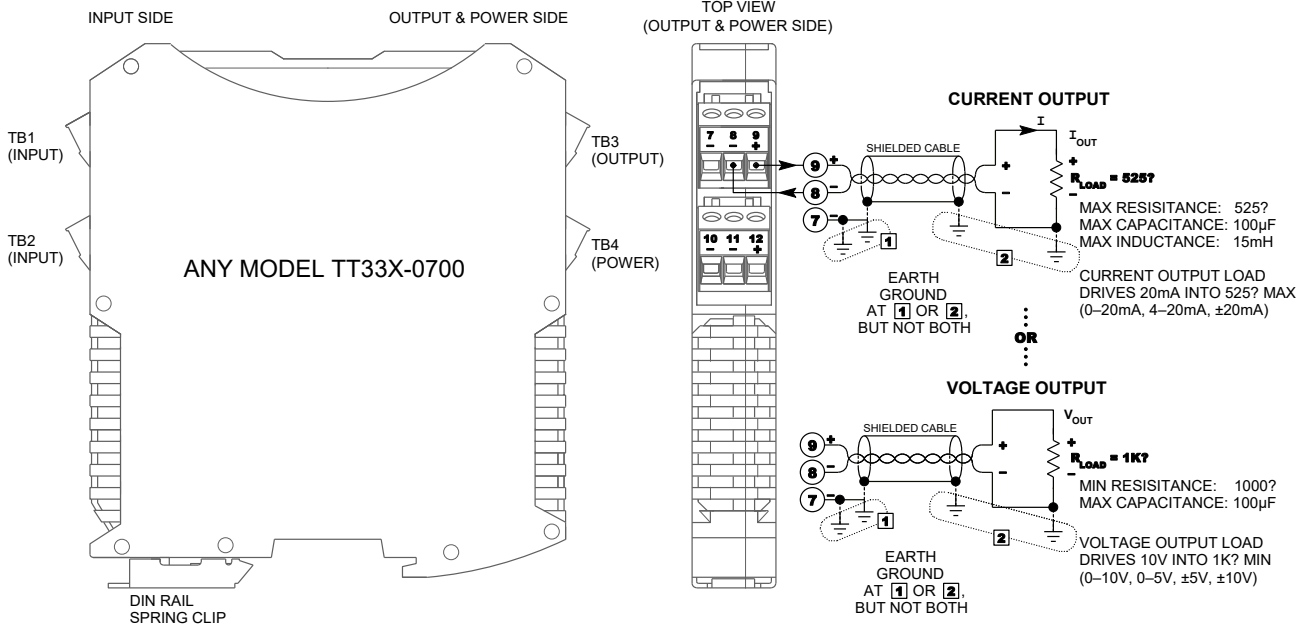

Observe proper polarity. Note that twisted-pair wiring is often used to connect the longest distance between the field transmitter output and the remote load as shown above. Additionally, shielded twisted pair wiring is recommended for best results. An output connection to earth ground will help protect the circuit from damage in noisy environments.

WARNING: For compliance to applicable safety and performance standards, the use of twisted pair output wiring is recommended. Failure to adhere to proper wiring and grounding practices as instructed may compromise safety, performance, and possibly damage the transmitter.

TIP – Ripple & Noise: Additional filtering placed at the load can help reduce 60Hz/120Hz ripple often present in industrial applications. For large 60Hz supply ripple, connect an external 1uF or larger capacitor directly across the load to reduce excessive ripple. For sensitive applications with high-speed acquisition at the load, high frequency noise may be reduced significantly by placing a 0.1uF capacitor directly across the load, as close to the load as possible.

Power Connections

This transmitter is powered from 12–32VDC (36VDC peak) by connecting power as shown below. This transmitter can be optionally powered (or redundantly powered) via the DIN rail bus when coupled to the DIN rail bus connector (Acromag Model 1005-063) and a bus terminal block (Acromag 1005-220 or 1005-221). This optional method can allow several modules to share a single power supply without wiring to each individually.

- Power connections are isolated from input and output. The supply voltage should be from 12–32VDC. This voltage must never exceed 36VDC peak, or damage to the transmitter may result.
- Variations in power supply voltage between the minimum required and 32VDC maximum, has negligible effect on transmitter accuracy.
- Note the placement of earth ground at input power. The power cable shield and DC– should ideally be grounded closest to the transmitter. Only one end of the connection should be grounded, never both.

CAUTION – Risk of Electric Shock: More than one disconnect switch may be required to de-energize this equipment before servicing.

IMPORTANT – External Fuse: If the transmitter is powered from a supply capable of delivering more than 2.5A to the transmitter, it is recommended that this current be limited via a high surge tolerant fuse rated for a maximum current of 2.5A or less (for example, see Bel Fuse MJS or RJS fuse types).

MODEL TT33X-0700 POWER WIRING
UNIT IS DC-POWERED ONLY AT 12 TO 32VDC.

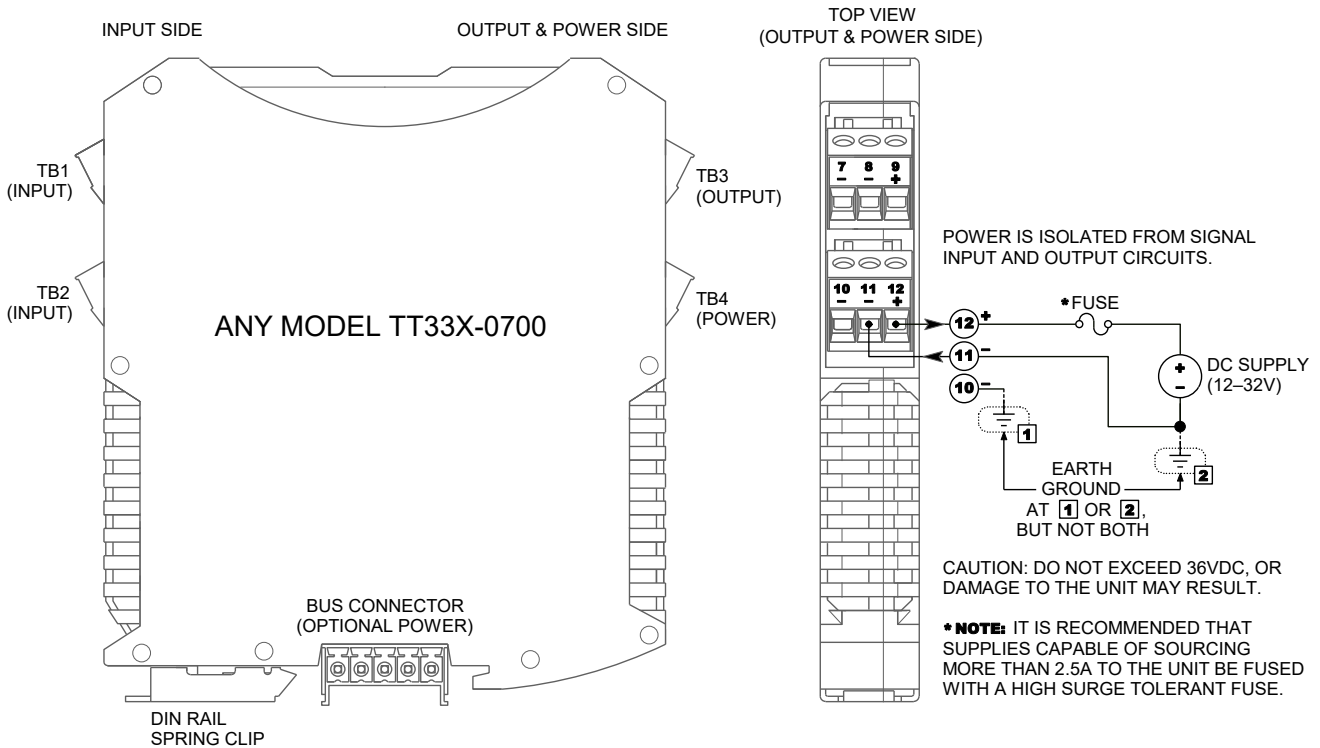

Optional Bus & Redundant Power Connections

Power is normally connected to the TB4 power terminals of the transmitter as shown on the previous page. However, this transmitter is equipped to be optionally powered via its DIN rail bus connector provided (Acromag 1005-063), when mated to an optional plug-in terminal block (Acromag 1005-220 or 1005-221). Power input via the bus connector terminal is diode-coupled to the same point as transmitter power connected at TB4 power.

Multiple modules may be powered by snapping them together along the DIN rail bus, then using the mating terminal block shown at left (select a Left or Right side connector). While the intent of the bus power connector is to allow several modules to conveniently share a single supply, the bus power connector may also be used to redundantly power modules, allowing a backup supply to maintain power to the module(s) should the main supply at TB4 fail.

This transmitter comes equipped with the bus connector 1005-063 shown below. This connector allows modules to snap together, side-by-side, along the DIN rail and share these connections. To complete connection to power, an optional bus terminal block is needed (Acromag 1005-220 for left-side, or 1005-221 for right-side connections). Refer to the figure on the following page which shows how to wire power to the optional bus connector using these connectors.



Important – End Stops: If this module uses the optionally powered (or redundantly powered) via the DIN rail bus for hazardous location installations (Class I, Division 2 or ATEX/IECEX Zone 2) it must use two end stops (Acromag 1027-222) to secure the terminal block and module (not shown).

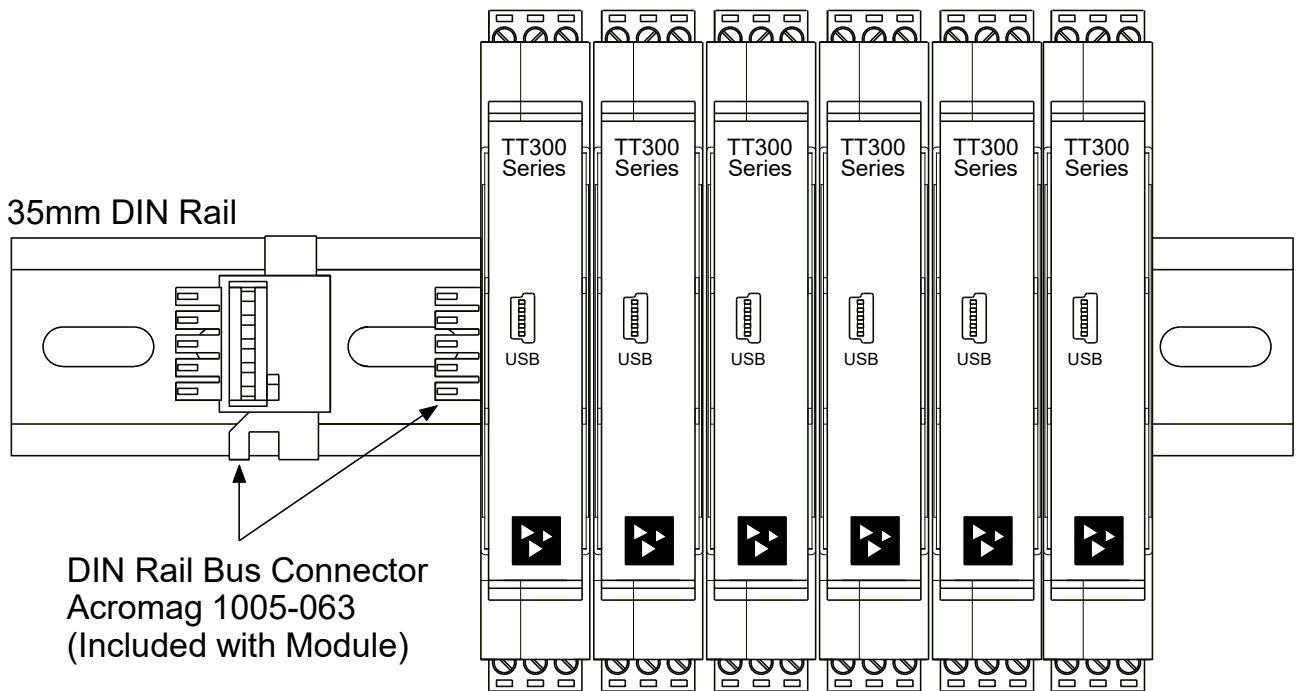

Optional Bus & Redundant Power Connections...

The figure below shows how to wire power to the optional bus terminal block when mated to the bus connector. Note that power is wired to the rightmost bus terminals on the right, or the left-most terminals on the left. Observe proper polarity.

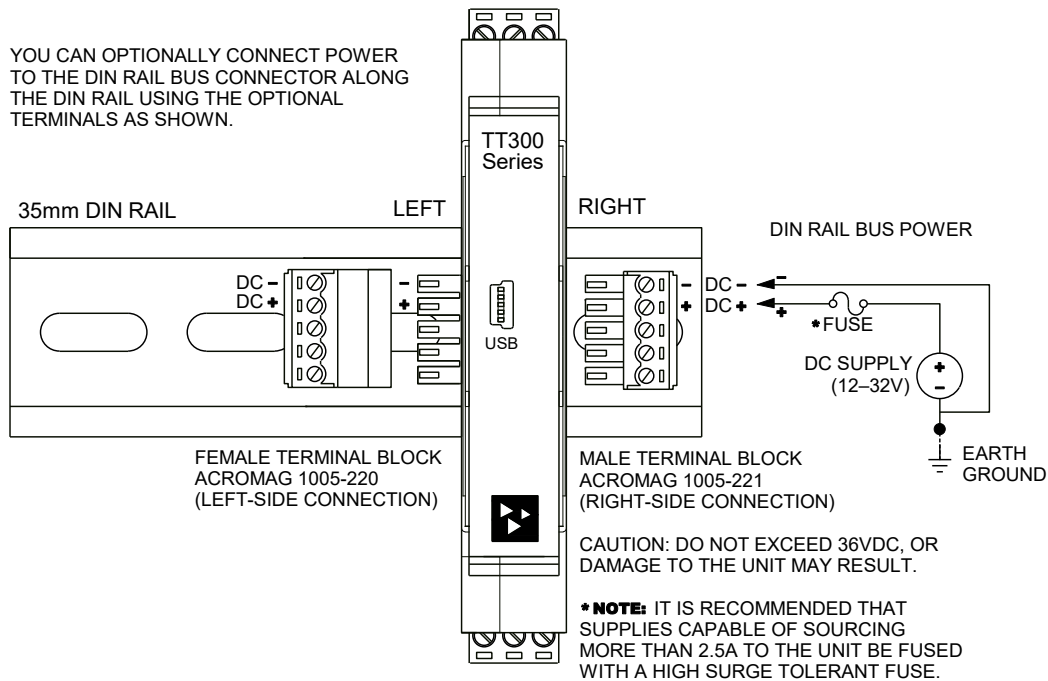

Earth Ground Connections

The module housing is plastic and does not require an earth ground connection. It does include a special connector that makes functional contact with the DIN rail if the DIN rail is grounded, but do not rely on this connection for earth ground. The internal input, output, and power circuits are electrically isolated from each other, allowing these circuits to be individually earth grounded as indicated. If the module is mounted in a metal housing, a ground wire connection is typically required for the enclosure and the metal enclosure's ground terminal (green screw) should be connected to earth ground using suitable wire per applicable codes.

See the Electrical Connections Drawings for Input, Output, and Power, and note the position of earth ground. Earth ground should be applied at the input power minus terminal (DC-). The input and output circuits are shunted to earth ground applied at the power minus terminal via internal isolation capacitors.

- Avoid inadvertent connections to earth ground at points other than those indicated, as this could drive ground loops and negatively affect operation.
- A USB isolator is recommended when configuring or calibrating a transmitter to avoid the ground loop that occurs if the input sensor is also earth grounded (PC USB ports are commonly earth grounded and make contact with both the USB signal and shield ground which is held in common to the input circuit ground of the transmitter).

USB Connections

This transmitter is configured and calibrated via configuration software that runs on Windows-based PCs connected to the transmitter via USB (Windows XP or later version required). Refer to the following drawing to connect a PC to the transmitter for the purpose of configuration

TT SERIES USB TRANSMITTER CONNECTIONS

USED FOR CONFIGURATION AND CALIBRATION OF THE TRANSMITTER IN A SAFE OR ORDINARY LOCATION

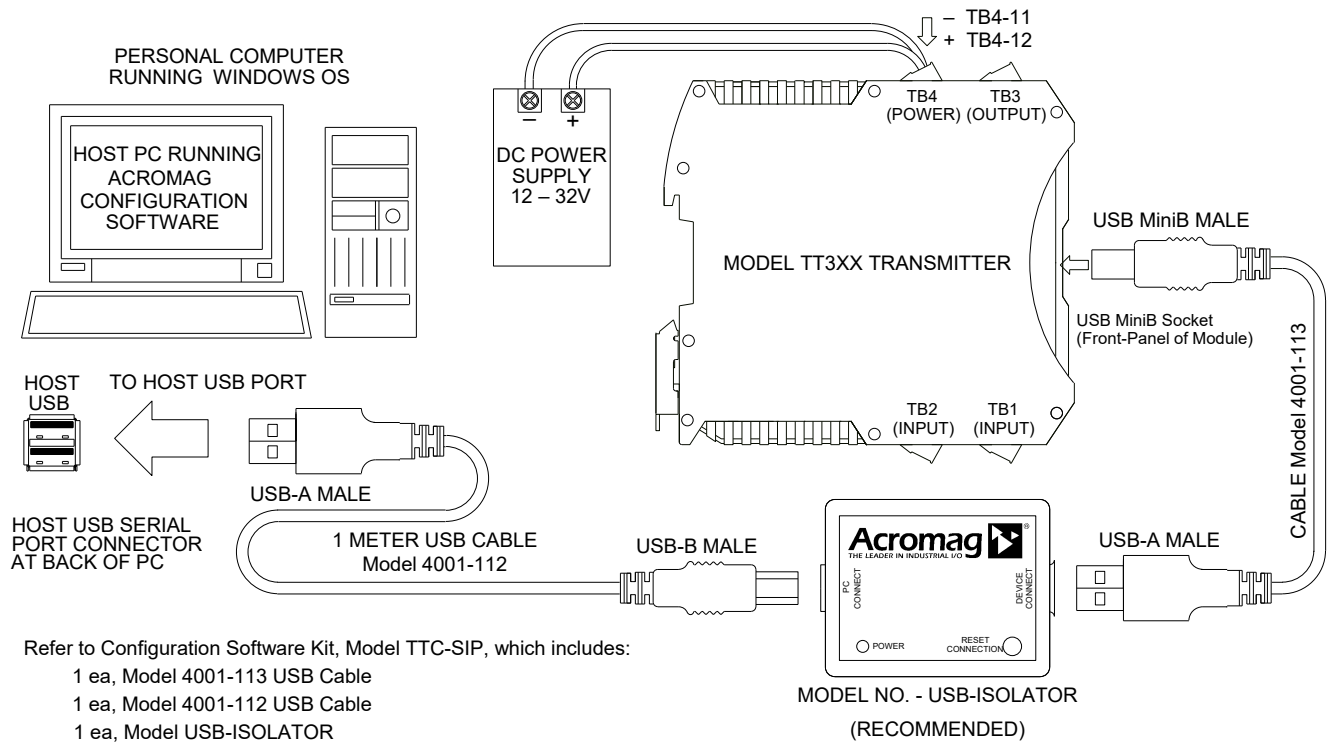

- Refer to Configuration Software Kit, Model TTC-SIP, which includes:
- 1 ea, Model 4001-113 USB Cable
 - 1 ea, Model 4001-112 USB Cable
 - 1 ea, Model USB-ISOLATOR
 - 1 ea, Configuration Software CDROM 5040-944

WARNING: 

The intent of mating USB with this transmitter is so that it can be conveniently configured and calibrated in a safe area, then installed in the field which may be in a hazardous area. Do not attempt to connect a PC or laptop to this transmitter while installed in a hazardous area, as USB energy levels could ignite explosive gases or particles in the air.

USB Signal Isolation is recommended and required when connected to a grounded input. Input and USB connections are isolated from the output of this transmitter. USB isolation is recommended for safety and noise suppression reasons, but required when the input signal is grounded (i.e. when non-insulated or grounded sensors are used). Acromag model USB-ISOLATOR may be used to isolate the USB port, or optionally a different USB signal isolator that supports USB Full Speed operation (12Mbps).

IMPORTANT: USB logic signals to the transmitter are referenced to the potential of the transmitter’s input ground. This ground is held in common with USB ground and USB cable shield ground. Thus, an isolator is required when the input signal is grounded and the transmitter is connected to the USB port of an earth-grounded PC. The use of an isolator can be avoided if a battery powered laptop PC is used to connect to the transmitter, and the laptop has no other earth ground connection, either directly or via a connected peripheral.

CONFIGURATION SOFTWARE

Quick Overview – Android



This transmitter can be configured and calibrated via the Acromag Agility™ Config Tool App. This software can be downloaded free of charge from the Google Play store at play.google.com. To connect to this transmitter, a USB OTG (On-The-Go) cable (Acromag 5028-565) and USB A to Mini-B cable (Acromag 4001-113) are required. This app is compatible with Android devices using Ice Cream Sandwich (4.0) or later.

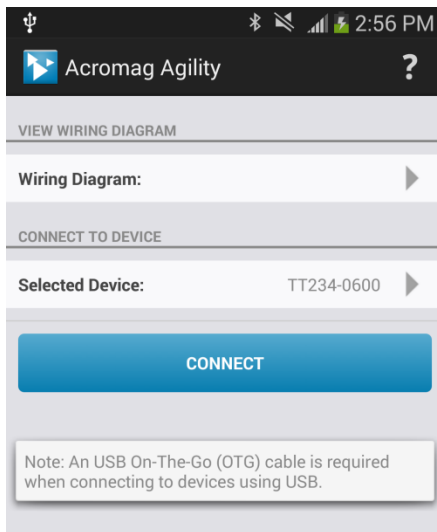

The initial connection screen of the app is shown at left. Once a device is connected, the main portion of the app will launch. The screen is divided into three tabs for this model. A short description of each tab follows.

Connection Screen Setup – DEVICE SELECT (First Connect to Unit Here)

- Select from connected transmitters by tapping the **[Select Device]** button. This will bring up a list of attached devices. Select the desired device and tap the Connect button to open the device.
- To view wiring diagrams of a particular transmitter, tap the **[Wiring Diagram]** button and select the desired model. Swipe left or right to view more diagrams. No connection is required to view the diagrams.
- Android requires user permission to access external hardware. If the Device List displays “No Device Permission”, select this device and when prompted to give permission to access the USB device, tap **[OK]**.

Configuration Tab – CONFIGURE I/O

- Once connected, the app will automatically read your transmitter and display its current configuration.
- Changing any option on this page will send the changes to the transmitter instantly. The device status at the bottom of the page will report if the changes were sent successfully.

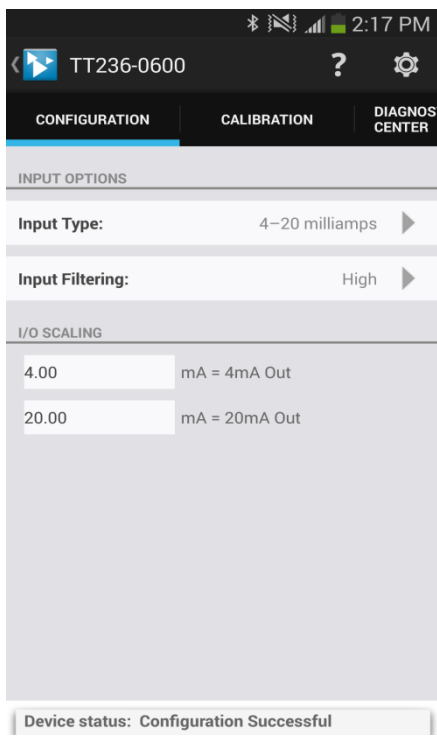

Calibration Tab – (Calibrate the Input and/or Output if Needed)

- On screen instruction will guide the setup to properly calibrate the transmitter. After completing instructions, tap the **[Calibrate]** button.
- The device status at the bottom of the page will report if the calibration was sent successfully.

Diagnostic Center Tab – (Verify Input operation)

- Select the polling indicator by tapping the **[Indicator]** button.
- Start polling by tapping the **[Start Polling]** button.

Utility Page – (Reboot or Restore Settings)

- Tap the **[Gear]** in the Action bar to access the Utility Page.
- You can tap the **[Restore/Reset Factory]** utility buttons to get out of trouble if you ever misconfigure or miscalibrate a transmitter.

Quick Overview – Windows

Click **“Open”** to connect to the TT335-0700 and the software will look similar to the following:

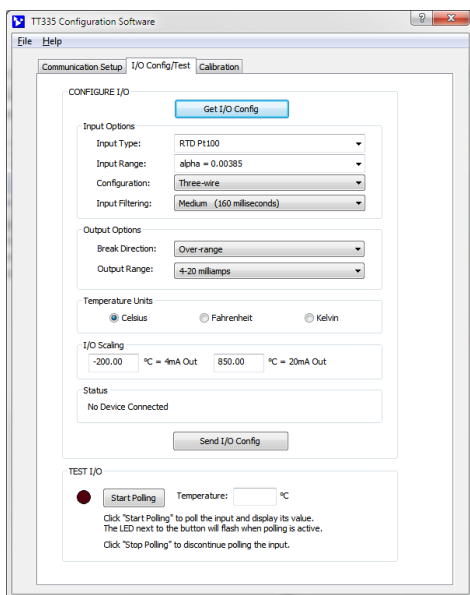
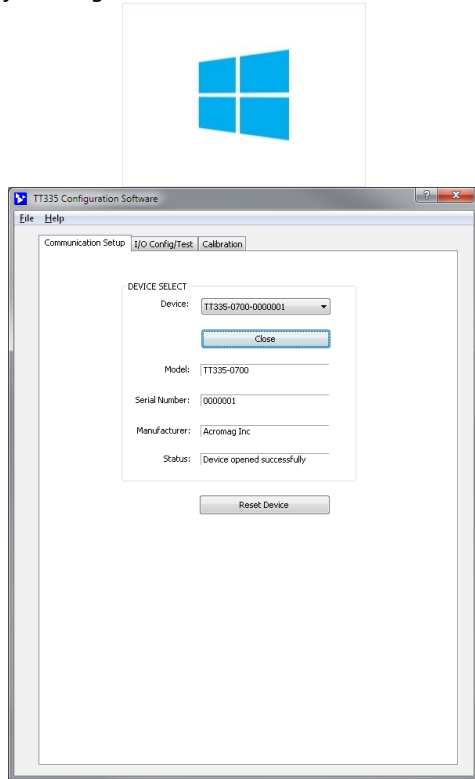

This transmitter can be configured and calibrated via its configuration software and a USB connection to a PC or laptop. The configuration software is contained in a zip file that can be downloaded free of charge from our web site at www.acromag.com. If you do not yet have a user account, you will need to create one before the download becomes accessible. The zip file will extract to an executable file which installs software to the “/Program Files/Acromag” directory on your computer. Note: You need administrator privileges on the PC you wish to install this software. Once installed, navigate to the “/Program Files/Acromag” directory and open the correct software for your particular model. This software is also included on a CDROM bundled with the Configuration Kit TTC-SIP (see Accessories). For this transmitter, use the software named **“TT335 Config.exe”**.

The initial configuration software window for this transmitter is shown at left. Configuration information is divided across three pages as follows: Communication Setup, I/O Config/Test, and Calibration.

Communication Setup (First Connect to Transmitter Here)

- Select from connected transmitters and Open/Close communication with them.
- Display the Model, Serial Number, and Manufacturer of the connected transmitter and report the status of communication.

I/O Config/Test (Configure and/or Test the Transmitter Here)

- Optional - Click the **[Get I/O Config]** button to retrieve the I/O configuration of the currently connected transmitter.
- Select the Input Type: RTD Platinum, Copper, Nickel, or Resistance.
- Select the Input Range: RTD alpha value, or resistance range.
- Select the Configuration: Four-wire, Three-wire, or Two-wire.
- Select the level of digital filtering: High, Medium, Low or None. The corresponding I/O response times are listed in parenthesis next to the filter selection.
- Select the Break Direction: Under-range or Over-range.
- Select the temperature units to use in the configuration software.
- Select the Output Range: $\pm 5V$, $\pm 10V$, $0-5V$, $0-10V$, $\pm 20mA$, $0-20mA$, or $4-20mA$.
- Enter the I/O Scaling. Specify the input temperatures to correspond to Zero-Scale and Full-Scale.
- Submit the configuration settings to the transmitter by clicking the **[Send I/O Config]** button to write the settings to the non-volatile EEPROM memory.

For detailed configuration and calibration procedures, see the **Operation Step-By-Step** section of the **Technical Reference** of this manual.

Quick Overview...

HELP:

You can press **[F1]** for Help on a selected or highlighted field or control. You can also click the **[?]** button in the upper-right hand corner of the window and click to point to a field or control to get a Help message pertaining to the item you pointed to.

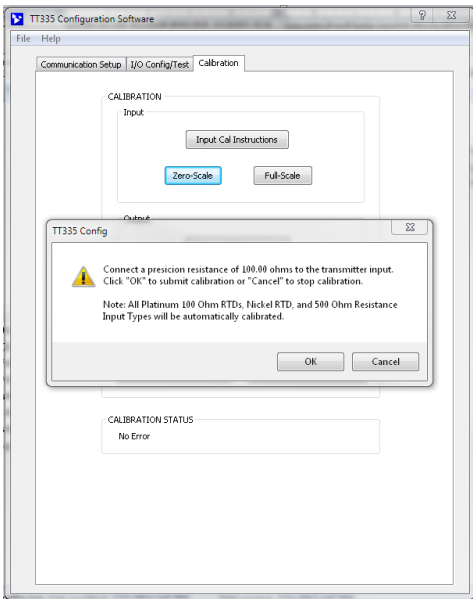
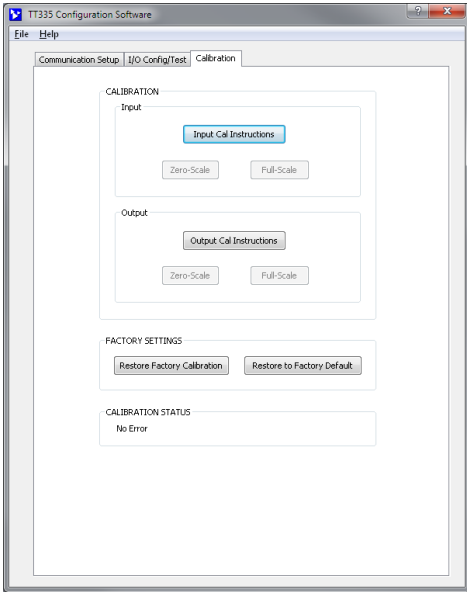

I/O Test (Optional, Verify Transmitter Operation Here)

After making I/O configuration changes, you can use the I/O Test controls to start/stop polling the input channel to check your input readings.

Click “Start Polling” to periodically read your input channel and validate its operation. Click “Stop Polling” to stop polling the input channel. Note the simulated red lamp next to the button flashes slowly when the software is polling the input channel.

CALIBRATION (Calibrate the Input and/or Output if Needed)

This transmitter has already been factory calibrated. If you encounter excessive error, you can click the Calibration tab to display the Calibration control page as shown at left.

To calibrate the Input or Output stage of this transmitter, simply click the respective “Cal Instructions” button and follow the prompts.

Input...

Before calibration, first select the Input Type to calibrate from the I/O Config page and be sure to click the **[Send I/O Config]** button. On the Calibration page, click the **[Input Cal Instructions]** button to begin input calibration.

When you click **[Zero-Scale]** or **[Full-Scale]** of the Input Calibration section, you will be prompted to apply a specific resistance at the input terminals. Once you have applied this resistance to the correct input pins, click the **[OK]** button of the prompt to calibrate the input.

Output...

Click the **[Output Cal Instructions]** button to begin output calibration. When you click **[Zero-Scale]** or **[Full-Scale]** of the Output Calibration section, you will be prompted to measure the output signal and enter the measurement in the field provided. Click the **[Submit Measurement]** button to calibrate the output.

Factory Settings (Use only in case of trouble or for sanitation purposes)

- Restore a transmitter to its original factory calibration
- Restore a transmitter to its initial factory configuration

You can click the **[Restore Factory]** buttons if you ever misconfigure or miscalibrate a transmitter in such a way that its operation appears erratic.

Calibration Status (Bottom of Window)

The Calibration Status bar at the bottom of the window will display status messages relative to calibration.

TECHNICAL REFERENCE

OPERATION STEP-BY-STEP

Connections

This section will walk you through the Connection–Configuration–Calibration process step-by-step. Before attempting to reconfigure or recalibrate this transmitter, verify the following electrical connections:

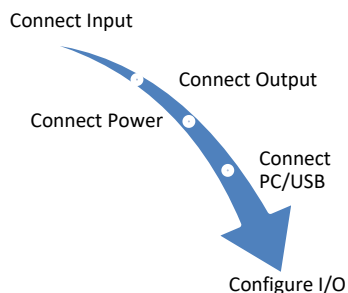

Calibration Connections:

NOTE: When calibrating, the input source, output meter, and load resistor (for current output) must be accurate beyond the transmitter specifications, or better than $\pm 0.1\%$. As a general rule, calibration equipment accuracy should be four times better than the rated accuracy you are trying to achieve with this transmitter.

Connect Input: Connect a precision resistance decade box to the input at TB1 and TB2 according to the RTD configuration you will be using (Refer to Sensor Input Connections). The resistance source must be adjustable over the range desired for zero and full-scale. All input types share the same wiring and procedure for the purpose of calibration.

Connect Output: Connect an output load to the transmitter appropriate for either current or voltage, as required by your application. You will need to measure the output current or voltage accurately in order to calibrate the output of the transmitter. You could connect a current meter in series with the load to read the output current directly, or a digital volt meter in parallel with the load to measure output voltage. Alternatively, you could simply connect a voltmeter across a precision load resistor, and then accurately read the output current as a function of the IR voltage drop produced in the resistor (recommended for current outputs).

Calibration & Configuration Connections:

Connect Power: Wire 12–32VDC power to the transmitter at TB4 as shown in the Electrical Connections section. Optionally, you may wire power to the bus terminal as shown in the optional power connections drawing. In either case, do not exceed 36VDC, or damage to the transmitter may result.

Apply power to the transmitter before connecting to USB. You will not be able to configure or calibrate the transmitter without power applied, as this transmitter does not use USB power.

Connect to PC via USB: Connect the transmitter to the PC using the USB isolator and cables provided in Configuration Kit TTC-SIP (refer to Electrical Connections section). You may omit the isolator if you are using a battery powered laptop PC to connect to the transmitter, or if your input source is not already grounded.

Now that you have made your connections and applied power, you can execute the “TT335 Config.exe” software to begin configuration of the transmitter (software is compatible with XP or later versions of the Windows operating system).

Connections...

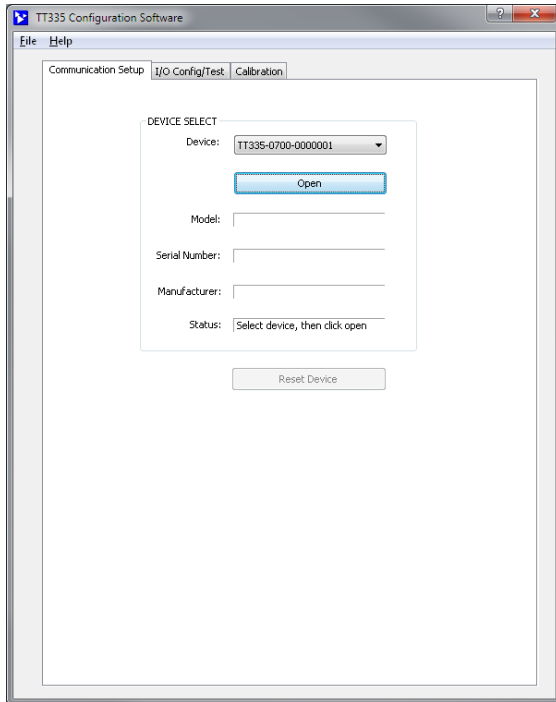

NOTE: You should already have power connected to the transmitter. You will not be able to configure, calibrate, or test the transmitter without power applied.

After executing the Acromag Configuration software for this transmitter, the window shown at left will appear, if you have not already connected to the transmitter via USB (note fields are blank under these conditions).

Connect your PC to the transmitter via USB, and the transmitter's model-serial information will appear in the device field as shown in the second window at left.

If you happen to be connected to more than one transmitter via a USB hub, you can use the device scroll field to select another transmitter, using the serial information suffix of the model number to discern one transmitter from another.

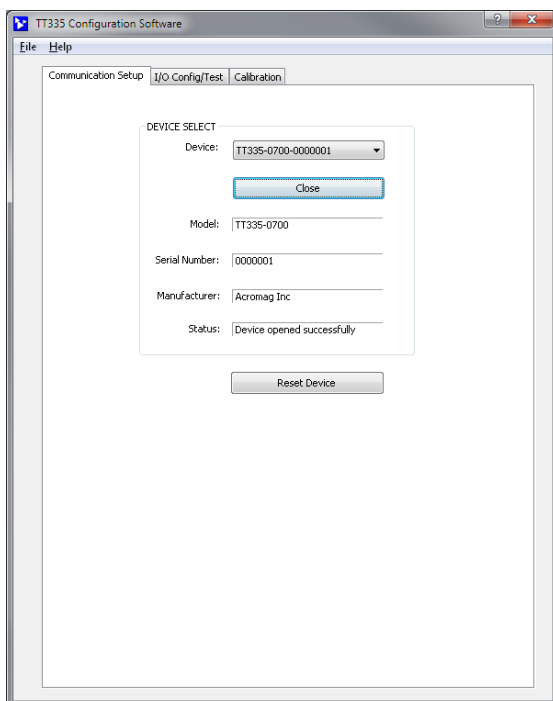

Select a transmitter from the drop down menu. When you click on a transmitter name from the drop down menu, the software will automatically attempt to open a connection with the selected transmitter. If the software does not have an open connection with the transmitter, click the **[Open]** button to open a connection with the transmitter.

After opening a connection to a transmitter, the transmitter's Model, Serial Number, Manufacturer, and connection status will be displayed as shown in the image on the left. In addition, the Status field will indicate "Device opened successfully" as shown in the image at left.

Configuration

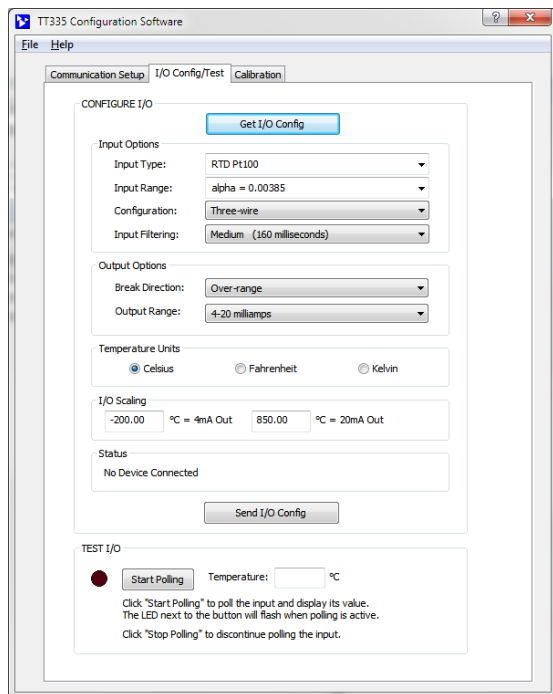
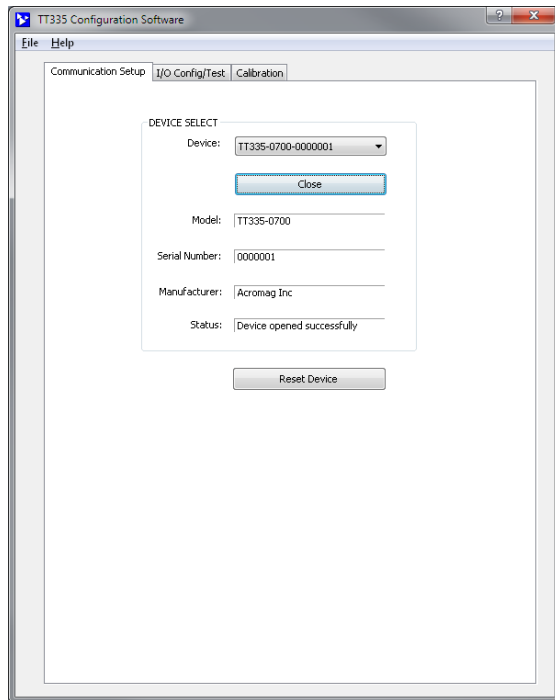

At this point, you can click the “**I/O Config/Test**” tab to begin configuring the transmitter, or to optionally test its operation. The I/O Config/Test window is the second image shown at left.

When you click the “I/O Config/Test” tab, the software retrieves the transmitter’s current configuration and displays it similar to the second image shown at left.

If you are connected to a transmitter, the initial I/O Config page represents the current configuration of the connected transmitter before making changes. Otherwise, if you have loaded the configuration from a saved a file, or if you have made changes to any fields, you can click the [**Get I/O Config**] button to retrieve the transmitter’s current configuration.

NOTE: If you make any changes to the selections indicated, the only way to preserve your changes is to write them to the transmitter by clicking the [**Send I/O Config**] button after completing your selections, or save them to a file by opening the “**File**” menu in the upper left-hand corner of the window.

Select the *Input Type*...

- If you select a RTD type, the output will be linear with respect to the sensor temperature.
- If you select Resistance, the output will be linear with respect to the input resistance, not temperature, and no special linearization will be performed.

Select the *Input Range*...

- If RTD Input Type is selected, then the Input Range menu will display RTD alpha values. Refer to “RTD Resistance versus Temperature” section for an explanation of alpha value.
- If Resistance Input Type is selected, then the Input Range menu will display resistance ranges. Select the lowest resistance range that can support the input resistance full-scale.

Select the *Configuration*...

- If you select “**Four-wire**”, the sensor lead-wire resistance will have a negligible effect on the sensor measurement.
- If you select “**Three-wire**”, the sensor lead-wire resistance will be compensated for, as long as the [+] and [L] leads are of the same length, size, and type.
- If you select “**Two-wire**”, the sensor lead-wire resistance will not be compensated for, and the total resistance of the \pm lead-wires will contribute a positive shift in the sensor measurement.

Configuration...

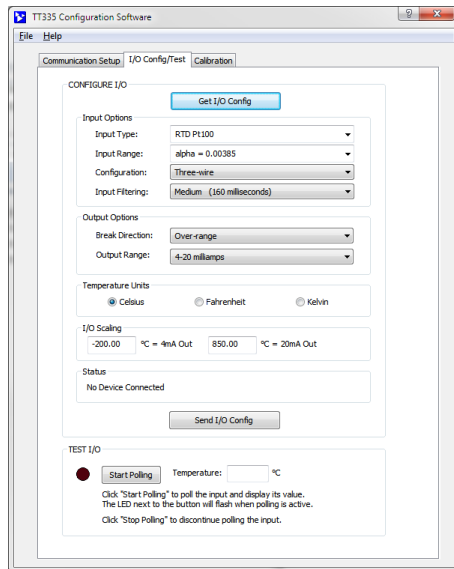

HELP:

You can press **[F1]** for Help on a selected or highlighted field or control. You can also click the **[?]** button in the upper-right hand corner of the window and click on a field or control to get a Help message pertaining to the item you clicked on.

NOTE:

A 5% under-range and over-range capability is built into the output range by design. See Output Specifications for more detail.

Select the Input Filtering...

Select the level of digital filtering to apply to the input channel as “None”, “Low”, “Medium”, or “High”. The respective I/O response times are indicated in parenthesis next to the filter selection. Note that higher filter levels results in lower average noise, but with slower I/O response times.

Select the Break Direction...

Upon sensor burnout or a broken sensor lead, you can select “Under-range” to send the output to its under-range limit, or “Over-range” to send the output to the over-range limit. Note that outputs can be reverse acting, but in the case, under-range and over-range remain normal. Under-range and over-range limits are 5% outside the nominal output range selected.

Select the Output Range...

The output terminals of this transmitter are universal and may drive DC current or voltage in the ranges $\pm 20\text{mA}$, 0-20mA, 4-20mA, $\pm 10\text{V}$, 0-10V, $\pm 5\text{V}$, and 0-5V. Voltage outputs may drive 1K Ω or higher loads, while current outputs may drive 525 Ω or less.

Select the Temperature Units...

Select the temperature units to use in the Configuration Software. You may select Celsius, Fahrenheit, or Kelvin.

Enter the I/O Scaling values...

You may rescale the input range to use only a portion of the input range to drive the output if desired. Be careful not to reduce the input range too much, as resolution will be proportionally diminished and noise/error magnified.

In the corresponding I/O Scaling field, enter the input signal minimum/zero value to correspond to the output range Zero-Scale value (i.e. -20mA, 0mA, 4mA, -10V, or 0V depending on the output range selected). Also set the input range Full-Scale (i.e. 20mA, 10V, or 5V, depending on the output range selected). You can optionally swap I/O Scaling values to configure a reverse acting output response if desired. Note: Approximately 5% under-range and over-range is built into each output range selection.

If the I/O Scaling Zero-Scale and Full-Scale points are chosen too close together, performance will be degraded.

Submit I/O Configurations

Once you have made your configuration selections, click the **[Send I/O Config]** button to write them to the transmitter. You can read the status of your sent message in the “Status” field. Alternately, you could click “**File**” in the upper left-hand corner to save the configuration settings to a file on your PC for later reference.

At this point, you can test the transmitter’s operation by clicking on the **[Start Polling]** button of the TEST I/O Section of the page to trigger the software to periodically read the input and display its value in the field to the right of the polling toggle button. Note the simulated lamp next to the button flashes each time the input is sampled. Click **[Stop Polling]** to stop polling the input.

Calibration (Optional)

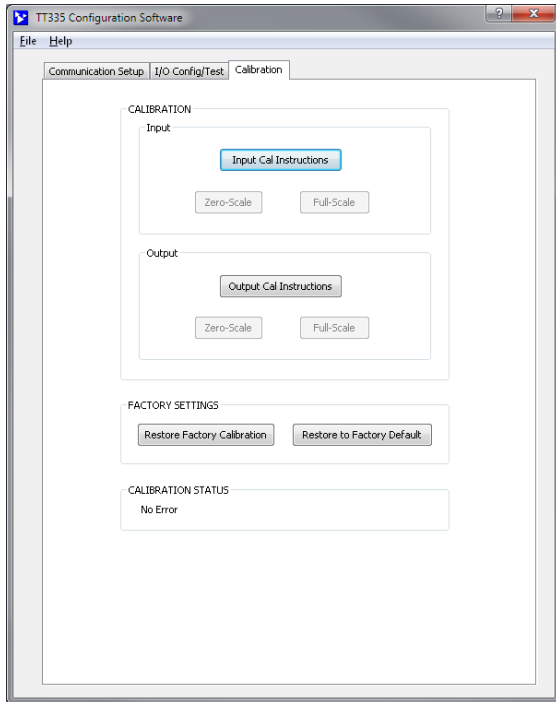

Once you’ve configured the transmitter, you are ready to install it in the field, as the transmitter has already been factory calibrated. If you later encounter error that is out of specification, you can click the “**Calibration**” tab to display the Calibration control page shown at left.

IMPORTANT: This transmitter has already had its input and output channels factory calibrated with a high level of precision. If you attempt to recalibrate the input or output channel, you could degrade its performance if it is not completed properly, or it is done using lower grade equipment. Consider your decision to recalibrate carefully.

Calibration – Input

Before attempting to recalibrate the input channel, make sure the selected Input Type on the “I/O Config” page is the desired sensor input type you intend to calibrate. Additionally, make sure you write your selections to the transmitter by clicking the [Send I/O Config] button.

Click the [Input Cal Instructions] button to begin input calibration and enable the Input [Zero-Scale] and [Full-Scale] buttons.

Click the Input [Zero-Scale] button of the Calibration Input section and you will be prompted to input a specific resistance at TB1/TB2. Once you input the resistance precisely, click the [OK] button of the prompt to calibrate zero-scale.

Click the Input [Full-Scale] button of the Calibration Input section and you will be prompted to input a specific at TB1/TB2. Once you input the resistance precisely, click the [OK] button of the prompt to calibrate full-scale.

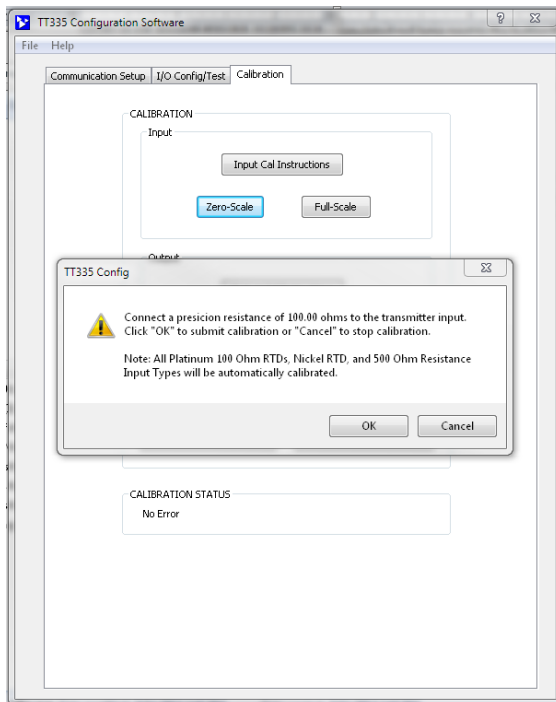

CAUTION – Input Calibration: Driving inputs outside of the nominal input range of the transmitter will not be acceptable for calibration of zero or full-scale. Since input levels cannot be validated during calibration, incorrect signal levels will produce an undesired output response.

Calibration (Optional)...

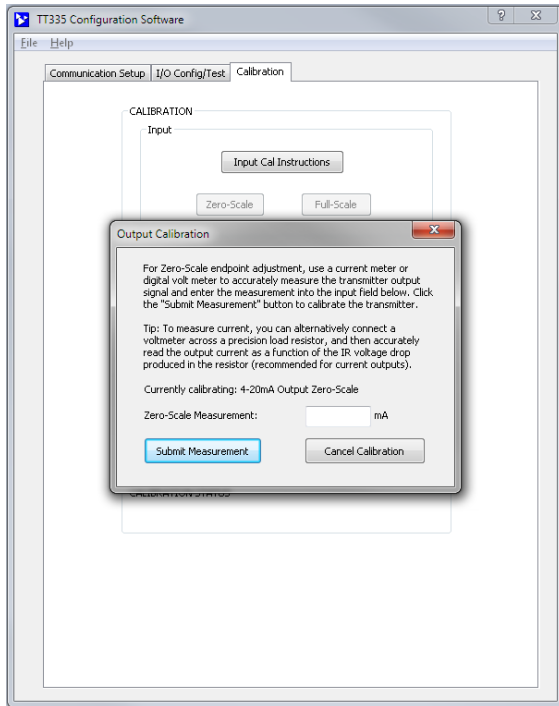

NOTE: To measure current, you can alternatively connect a voltmeter across a precision load resistor, and then accurately read the output current as a function of the IR voltage drop produced in the resistor (recommended for current outputs).

Factory Settings

Calibration Status

Calibration – Output

Before attempting to recalibrate the output channel, first make sure the selected Output Range you wish to calibrate has been selected on the “I/O Config” tab. Additionally, make sure you write your selections to the transmitter by clicking the [Send I/O Config] button.

Click the **[Output Cal Instructions]** button to begin output calibration and enable the Output **[Zero-Scale]** and **[Full-Scale]** buttons.

For output zero-scale endpoint adjustment, click the **[Zero-Scale]** button to open the zero-scale configuration popup. Use a current meter or digital volt meter to accurately measure the transmitter output signal and enter the measurement into the input field provided. Click the **[Submit Measurement]** button to send the calibration to the transmitter.

For output full-scale endpoint adjustment, click the **[Full-Scale]** button to open the full-scale configuration popup. Use a current meter or digital volt meter to accurately measure the transmitter output signal and enter the measurement in the input field provided. Click the **[Submit Measurement]** button to send the calibration to the transmitter.

If your output acts erratic or appears imprecise, you may need to repeat input or output calibration, being very careful to take accurate measurements and input correct signal levels. For current outputs, if you are measuring a voltage across a load resistance, make sure that you use the exact resistance when calculating the load current being measured. Also, when rescaling to a smaller sub-range, make sure that you have adequate input span. Input spans that are too small will have diminished resolution and will magnify error.

The **[Restore Factory Calibration]** button resets transmitter and causes it to revert to its factory calibration without effecting user configuration. Useful if there was an error during recalibration that degraded performance or the I/O channel appears erratic.

The **[Restore Factory Default]** button restores a transmitter to its original factory state (See Specifications Reference Test Conditions). This includes calibration and configuration. This control can be used as a sanitation tool to restore the transmitter to its initial configuration.

This field displays calibration status messages such as “No Error”, “No Device Connected”, “Calibration Error”, “Transfer Error”, and “Timeout Error” during calibration. If you encounter an error, you may have to repeat the calibration process.

RTD Resistance versus Temperature

TEMP °C	Temperature in Ohms					
	100Ω Platinum RTD				120Ω Nickel RTD (α = 0.006872)	10Ω Copper RTD (α = 0.004274)
	α = 0.00385	α = 0.00390	α = 0.003911	α = 0.00392		
-200	18.520	17.396	17.260	17.079		1.058
-150	39.723	38.903	38.789	38.648		3.113
-100	60.256	59.721	59.638	59.543		5.128
-50	80.306	80.044	80.000	79.952	86.17	7.104
-40	84.271	84.061	84.026	83.988	92.76	7.490
-30	88.222	88.065	88.038	88.010	99.41	7.876
-20	92.160	92.056	92.038	92.019	106.15	8.262
-10	96.086	96.034	96.025	96.015	113.00	8.649
0	100.000	100.000	100.000	100.000	120.00	9.035
+10	103.903	103.954	103.963	103.973	127.17	9.421
+20	107.794	107.896	107.915	107.934	134.52	9.807
+30	111.673	111.827	111.855	111.883	142.06	10.194
+40	115.541	115.745	115.783	115.821	149.79	10.580
+50	119.397	119.652	119.700	119.747	157.74	10.966
+60	123.242	123.547	123.605	123.661	165.90	11.352
+70	127.075	127.429	127.498	127.563	174.25	11.738
+80	130.897	131.300	131.379	131.454	182.84	12.125
+90	134.707	135.160	135.249	135.333	191.64	12.511
+100	138.506	139.007	139.107	139.200	200.64	12.897
+150	157.325	158.066	158.222	158.360	248.95	14.828
+200	175.856	176.828	177.044	177.226	303.46	16.776
+250	194.098	195.294	195.574	195.799	366.53	18.725
+300	212.052	213.463	213.811	214.079	439.44	
+350	229.716	231.336	231.756	232.065		
+400	247.092	248.912	249.409	249.758		
+450	264.179	266.192	266.769	267.157		
+500	280.978	283.175	283.836	284.263		
+550	297.487	299.862	300.611	301.075		
+600	313.708	316.252	317.094	317.594		
+650	329.640	332.346	333.284	333.820		
+700	345.284	348.143	349.181	349.752		
+750	360.638	363.644	364.787	365.391		
+800	375.704	378.848	380.099	380.736		
+850	390.481	393.756	395.119	395.788		

NOTE: 200Ω, 500Ω, and 1000Ω Platinum RTD resistances can be calculated based on the table above. For 200Ω Platinum, multiply the resistances in the table by 2. For 500Ω Platinum, multiply the resistances in the table by 5. For 1000Ω Platinum, multiply the resistances in the table by 10.

NOTE: Alpha (α) is used to identify the RTD curve and its value is derived by dividing the sensor resistance at 100°C (boiling point of water) minus the sensor resistance at 0°C (freezing point of water), by the sensor resistance at 0°C, then by 100°C ($\alpha = [R_{100^\circ\text{C}} - R_{0^\circ\text{C}}] / R_{0^\circ\text{C}} / 100^\circ\text{C}$). For Pt100Ω α=0.00385, this is 38.5Ω/100.0Ω/100°C, or 0.00385Ω/Ω/°C.

BLOCK DIAGRAM

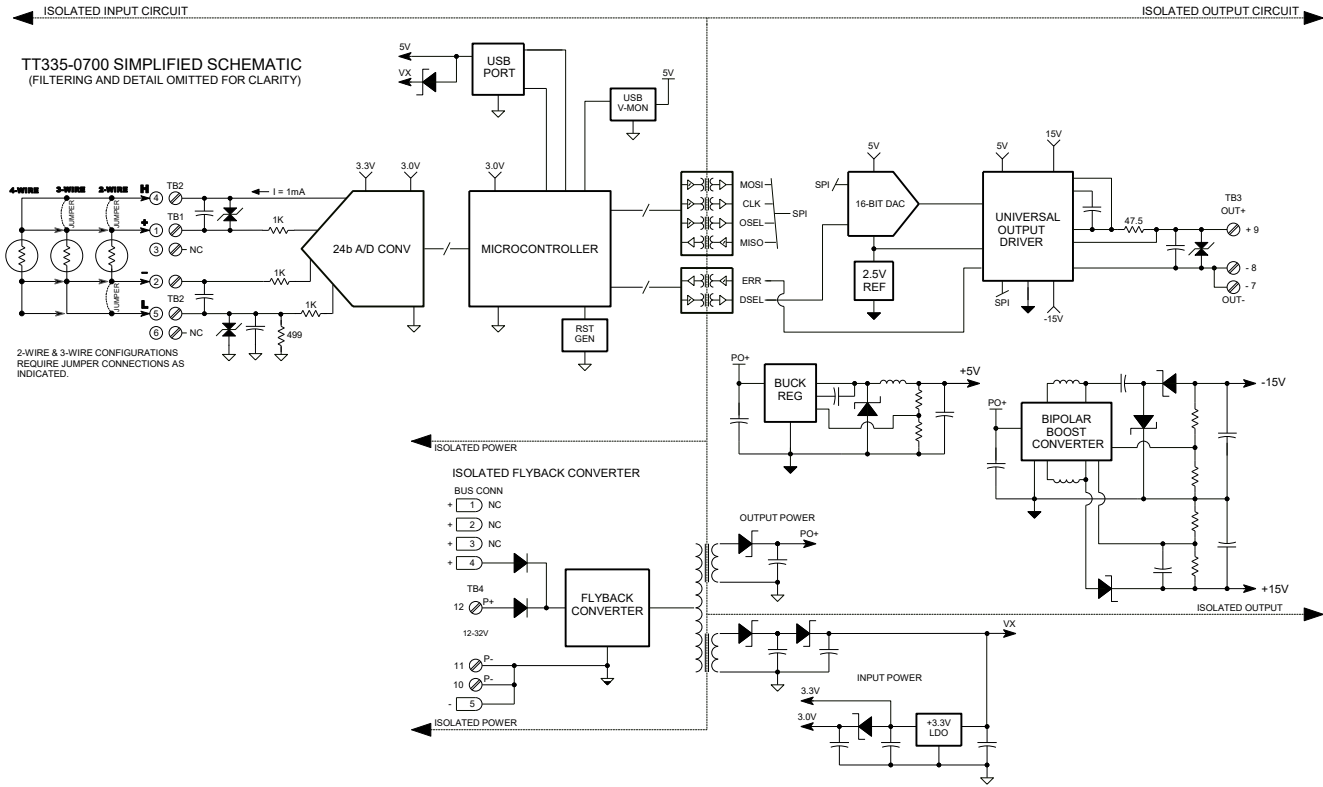

How It Works

Key Points of Operation

- DC Powered
- Isolated Power
- Isolated Input
- Isolated Output
- Input circuit is common to USB ground
- Universal output, current or voltage

The TT335 transmitter uses a 32-bit microcontroller and a high-resolution 24-bit ADC to digitize the input signal and communicate to the output DAC via an SPI bus. The SPI bus passes through digital isolators and is received by a 16-bit output DAC which drives a universal output driver for current or voltage. The output is very unique in that it may drive current or voltage to the load without having to change load connections (only the load resistance must be adjusted). The output type and range are user-configured. Power for the isolated input and isolated output circuits is provided via an isolated flyback converter that operates on voltage wired to the power terminals at TB4, or wired to optional bus power terminals along the DIN rail.

Setup involves selecting the input type, lead-break direction, temperature units, output range (current or voltage), filter level, and choosing I/O Scaling values. I/O scaling can also be done in reverse to produce a reverse acting output signal. Refer to the block diagram above to gain a better understanding of how this transmitter works.

The input/USB, output, and power circuits are all isolated from each other. This transmitter does not draw power from USB and the USB port ground is common to the input circuit ground. The USB port ground of most PC's is also common to the USB cable shield and earth ground. Input sensors could be grounded or ungrounded. For this reason, it is recommended that USB signals be isolated when connected to a PC to prevent a ground loop from occurring between the PC earth ground and a grounded input sensor, which would have the negative affect of pulling the input bias supply to ground and clipping any negative range.

TROUBLESHOOTING

Diagnosics Table

Before attempting repair or replacement, be sure that all installation and configuration procedures have been followed and that the transmitter is wired properly. Verify that power is applied to the transmitter and that the supply voltage is at least 12V.

If the problem still exists after checking the wiring and reviewing this information, or if other evidence points to another problem with the transmitter, an effective and convenient fault diagnosis method is to exchange the questionable transmitter with a known good transmitter.

Acromag’s Application Engineers can provide further technical assistance if required. Repair services are also available from Acromag.

POSSIBLE CAUSE	POSSIBLE FIX
Cannot Communicate with Transmitter via USB...	
Output shifts off-range when USB is connected...	
Output Erratic, Not operational, or at Wrong Value...	
Transmitter fails to operate or exhibits an output shift...	
A missing USB Isolator could cause a ground loop between a grounded input sensor and earth ground at the connected PC’s USB port.	Without a USB isolator, a ground loop is possible between a grounded input signal source and earth ground of the PC USB port. It is best to connect to USB via a USB isolator for this reason, and for increased safety and noise immunity. Use an isolator like the Acromag USB-ISOLATOR. Otherwise, use a battery powered laptop to configure the transmitter which does not normally earth ground its USB port.
Software Fails to Detect Transmitter...	
Bad USB Connection	Recheck USB Cable Connection
USB has not enumerated the transmitter.	Use the reset button on the Acromag USB isolator to trigger re-enumeration of the transmitter, or simply unplug/re-plug the USB cable to the transmitter.
Communication or power was interrupted while USB was connected with the configuration software running.	Close the current connection with the software, select and re-open the transmitter for communication (or simply exit the configuration software and restart it).
For an input step, the output appears to make 2 steps to reach its final value...	
For a step change in the input, the ADC requires 2 input samples to fully characterize the input signal.	The ADC requires two samples to fully characterize the input signal, and this is evident when using a scope to examine the output transition in response to a step change at the input, which makes two steps in its transition to its final level.
Output goes immediate to Over-Range (105%) or Under-Range Limit...	
This indicates that either the input signal is out of range, or a sensor lead has broken. It can also occur due to contention between earth ground at the PC USB port and the input sensor.	Check the input signal with respect to its range and reduce or increase it as required to drive the output within its linear operating range. A fully Over-Range or Under-Range signal can be driven by a sensor fault, such as an open or broken sensor lead. If USB is not isolated, check for a ground loop between a grounded sensor and earth ground of the PC USB port.

Diagnostics Table...

POSSIBLE CAUSE	POSSIBLE FIX
<i>Cannot Calibrate Input Channel...</i>	
Is input wired properly?	Check that input is wired to \pm input terminals using correct polarity.
<i>Cannot Measure Input Temperature or Resistance...</i>	
Input may be wired incorrectly to the input terminals.	Verify that the sensor or resistance decade box is wired to the transmitter correctly. Refer to Sensor Input Connections for wiring sensors to the transmitter.

Service & Repair Assistance

This transmitter contains solid-state components and requires no maintenance, except for periodic cleaning and transmitter calibration and verification (zero and full-scale). Its enclosure is not meant to be opened for access and can be damaged easily if snapped apart. It is highly recommended that a non-functioning transmitter be returned to Acromag for repair or replacement. Acromag has automated test equipment that thoroughly checks and calibrates the performance of each transmitter, and can restore firmware. Please refer to Acromag’s Service Policy and Warranty Bulletins, or contact Acromag for complete details on how to obtain repair or replacement.

ACCESSORIES

Software Interface Package



Software Interface Package/Configuration Kit – Order TTC-SIP

- USB Signal Isolator
- USB A-B Cable 4001-112
- USB A-mini B Cable 4001-113
- Configuration Software CDROM 5040-944

This kit contains all the essential elements for configuring TT230 & TT330 family Transmitters. Isolation is recommended for USB port connections to these transmitters and will block a potential ground loop between the PC and a grounded current loop. A software CDROM is included that contains the Windows software used to program the transmitter.

USB Isolator



USB Isolator – Order USB-ISOLATOR

- USB Signal Isolator
- USB A-B Cable 4001-112
- Instructions 8500-900

This kit contains a USB isolator and a 1 meter USB A-B cable for connection to a PC. This isolator and cable are also included in TTC-SIP (see above).

USB A-B Cable



USB A-B Cable – Order 4001-112

- USB A-B Cable 4001-112

This is a 1 meter, USB A-B replacement cable for connection between a PC and the USB isolator. It is normally included with the TTC-SIP Software Interface Package and also with the isolator model USB-ISOLATOR.

USB A-mini B Cable



USB A-mini B Cable – Order 4001-113

- USB A-mini B Cable 4001-113

This is a 1 meter, USB A-miniB replacement cable for connection between the USB isolator and the transmitter. It is normally included in the TTC-SIP.

Note that software for all TT Series models is available free of charge, online at www.acromag.com.

USB OTG Cable



USB OTG Cable – Order 5028-565

- USB OTG Cable 5028-565

This is a 6 inch, USB On-The-Go cable for connection between the USB A-mini B Cable and a mobile phone or tablet. It is required to use the Acromag Agility™ Config Tool App.

Note that the Acromag Agility™ Config Tool is available free of charge, online at the Google Play store.

DIN Rail Bus Connector Kit

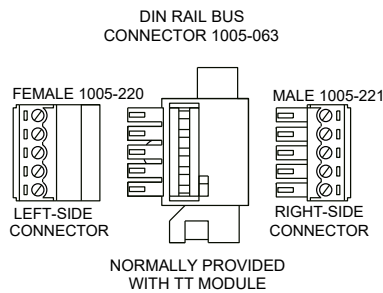

Bus Connector Kit for DIN Rail Bus Connection to Power Model TTBUS-KIT

This kit contains one each of the following terminals

- DIN Rail Bus Connector 1005-063 for 17.5mm TT Modules.
- Left Side terminal block, female connector 1005-220.
- Right Side terminal block, male connector 1005-221.
- Two End Stops for 35 mm DIN Rails 1027-222 (not shown).

This module was shipped with the first item included in this kit, DIN Rail Bus Connector 1005-063, and this kit offers a spare. Left and right side terminal blocks that mate directly to the bus connector are included in this kit. These terminals are used to optionally (or redundantly) drive power to Series TT modules via their DIN rail bus connector. This also allows modules to neatly and conveniently share connections to Power. Two end stops 1027-222, used to secure the terminal block and module for hazardous location installations.

End Stops



Two End Stops – Order 4001-252

- Two 1027-222 End Stops for 35 mm DIN Rail mounting

For hazardous location installations (Class I, Division 2 or ATEX/IECEx Zone 2), you can use two end stops (Acromag 1027-222) to help secure modules to 35mm DIN rail (not shown).

SPECIFICATIONS

Model Number

Model TT335-0700

- Signal Transmitter
- Isolated RTD Input
- Four-Wire Powered
- CE Approved
- Includes UL/cUL Class I, Division 2 approvals

Custom calibration to customer specifications can be added as a separate line item at time of purchase.

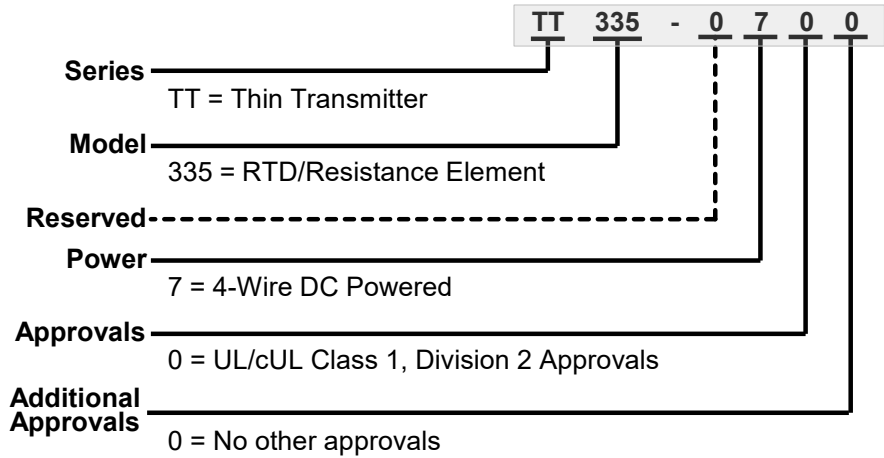

Optional factory calibration to customer specifications is ordered as a separate line item at time of purchase, and on a per unit basis. Factory calibration will require the specification of input type, input range zero, input range full-scale, Steinhart-Hart or Beta constants for Thermistor input types, and output range. Normal or reverse acting output and a filter level can also be specified. Use form 8500-858 for specifying this calibration from our web site at www.acromag.com.

The standard model without adding custom factory calibration is calibrated by default to reference test conditions. Recalibration of any transmitter will require use of a TTC-SIP configuration kit, ordered separately (see Accessories section). Modules can be mounted on standard 35mm “T” Type DIN rail.

Input

Input Reference Test Conditions: 100Ω Pt RTD, $\alpha = 0.00385$; -200°C to 850°C input; Configuration = Three-wire; Filtering = Medium; Output = 4 to 20mA, ascending; R-Load = 250Ω. Break detection = Over-range; Ambient = 25°C; Power supply = 24VDC;

Input Configuration: Four-wire (lead-wire has negligible effect), three-wire with lead-wire compensation, and two-wire without lead-wire compensation.

Input Impedance: 15.4MΩ, typical.

Input Overvoltage Protection: Bipolar Transient Voltage Suppressors (TVS) rated up to 5.6V working voltage, typical. Also includes capacitive filtering, and series resistance.

Input Filtering: Normal mode RC filtering, plus digital filtering, optimized and fixed per input range and filter selection within the Σ - Δ ADC. See Normal Mode Noise Rejection and Output Response Time.

Input Excitation Current: Set to 0.1mA, 0.2mA, 0.5mA, 1mA typical, for Inputs 1000Ω, 500Ω, 200Ω, 100Ω & Nickel & Copper respectively. Drift over temperature has negligible effect due to ratiometric measurement technique.

Input Response Time: See output response time.

Input Linearization (RTD Inputs): Preset for input.

Input...

Table 1 – Input Ranges & Accuracy:

Input Sensor Ranges and Accuracy at Reference Test Conditions		
Input Type	°C or Ω Spans in Range	Typical Accuracy
Pt 100Ω	-200°C to +850°C	±0.25°C
Pt 200Ω	-200°C to +850°C	±0.30°C
Pt 500Ω	-200°C to +850°C	±0.50°C
Pt 1000Ω	-200°C to +850°C	±1.00°C
Ni 120Ω (Minco 7-120)	-80°C to +320°C	±0.08°C
Cu 10Ω (Minco 16-9)	-200°C to +270°C	±1.00°C
Resistance (Linear)	0 to 25Ω ¹	±0.05Ω
	0 to 450Ω	±0.10Ω
	0 to 900Ω ¹	±0.90Ω
	0 to 2250Ω ¹	±2.25Ω
	0 to 4500Ω ¹	±4.50Ω

Note: ¹These ranges only available on device firmware revision D or later.

Analog to Digital Converter (ADC): Input utilizes a 24-bit, Σ-Δ ADC converter, with only the first 16-bits used. (see Input Resolution below).

Input Resolution: The ADC of this model divides the input signal range into a number of parts that can be calculated using the expression for ADC counts as $32768 \cdot R_{IN} \cdot \text{Gain} / 499$, with Gain=1 for all input types except Copper RTD, which is set to Gain=16. R_{IN} is the resistance of the input the sensor. An indication of nominal input resolution is expressed as the number of parts between the input range low and high endpoints shown in the following table.

Input Resolution per Input Type		
Input Type	α Alpha ¹	ADC Input Resolution
Pt 100Ω, 200Ω, 500Ω, 1000Ω	0.00385	1 part in 24425
	0.00390	1 part in 24714
	0.003911	1 part in 24812
	0.00392	1 part in 24868
Ni 120Ω (Minco 7-120)	0.006872	1 part in 26569
Cu 10Ω (Minco 16-9)	0.004274	1 part in 19384
Resistance (0 to 25 Ohms)	N/A	1 part in 26172
Resistance (450, 900, 2250, 4500 Ohms)	N/A	1 part in 29491

Notes: ¹Alpha (α) is used to identify the RTD curve. Refer to “RTD Resistance versus Temperature” section for an explanation of alpha value. This transmitter allows a portion of the nominal input range to be rescaled to the output range selected. However, the effective input resolution will be proportionally diminished as the input range span is reduced below its nominal span. The effective I/O resolution of this transmitter will be the lowest resolution of the ADC itself or the output DAC (output DAC is 1 part in 46984 for 4-20mA).

Input...

Input Zero and Full-Scale Adjustment: Nominal input ranges are selectable and range endpoints are adjustable over the full range of input temperature/resistance. Input Zero and Full-Scale selections must be within the nominal range and will be mapped to 0% and 100% at the output. Keep in mind that the input resolution diminishes below nominal as the programmed input range is reduced. Likewise, error is magnified as the input span is reduced.

Sampling Rate (ADC): Input is sampled at a variable rate according to the input filter selection as follows:

ADC Sampling rate (Samples/Second) per Input Filter			
None	Low	Medium	High
107.325sps	42.93sps	12.63sps	1.665sps

Noise Rejection (Common Mode): Varies with input and input filter selection between 92dB (no filter) and 124dB (high filter), typical with 100Ω input unbalance.

Noise Rejection (Normal Mode): Varies with input and input filter selection. Table below indicates the typical rejection at 60Hz for each input and input filter selection. Note that at the medium and high filter settings, the ADC converter adds 80dB minimum of rejection for frequencies between 49Hz and 61Hz.

Typical 60Hz Rejection per Input Filter			
None	Low	Medium	High
17dB	34dB	> 80dB	> 80dB

Lead-Wire Compensation: Requires balanced [+] and [L] sensor leads (same size, length, & type) and only used with three-wire configuration.

Lead-Wire Resistance Effect: Four-wire configuration: Less than 0.001°C per Ω of unbalance, typical. Three-wire and two-wire configurations: 3.5°C per Ω of unbalance, typical (Pt100), 1.4°C per Ω of unbalance, typical (Ni), 25.5°C per Ω of unbalance, typical (Cu). Maximum resistance of 25Ω per lead.

Lead-Wire Break/Burnout Detection: Can be set for Over-range or Under-range open sensor or lead break detection. Limits are output range dependent. Over-range output limit is approximately 21mA, 10.5V, or 5.25V depending on the output range selected. Under-range limit is approximately -21mA, 0mA, 3.5mA, -0.25V, or -10.5V depending on the output range selected.

Output

Output Range: Can be configured for one of seven nominal output ranges shown below. All output ranges include approximately 5% under/over-range capability.

Output Range	Output Range with Under/Over-Range
-10V to +10V	-10.5V to +10.5V
-5V to +5V	-5.25V to +5.25V
0 to +10V	-0.5527V to +10.5V
0 to +5V	-0.27634V to +5.25V
±20mA	-21mA to +21mA
0 to +20mA	-1.1054mA to +21mA
+4mA to +20mA	-1.1054mA to +21mA

Output...

Output Accuracy: Accuracy is better than $\pm 0.05\%$ of output span, typical ($\pm 0.1\%$ maximum), for input spans 10% to 100% of full range. Relative accuracy varies with calibrated input and output span. This includes the effects of repeatability, terminal point conformity, and linearization, but does not include sensor error.

Output Load: Voltage output can drive loads down to $1\text{k}\Omega$ minimum. Current output can drive 21mA DC into $0\text{--}525\Omega$.

Output Load Resistance Effect: Less than $\pm 0.005\%$ of output span effect for $\pm 100\Omega$ change in load resistance.

Output Ripple/Noise: Less than $\pm 0.1\%$ of output span.

Note (High Speed Acquisition): Additional filtering at the load is recommended for sensitive applications with high-speed acquisition rates. High frequency noise is often reduced or eliminated by placing a $0.1\mu\text{F}$ capacitor directly across the load. For excessive 60Hz supply ripple with current output, a $1\mu\text{F}$ or larger bulk capacitor is recommended at the load.

Output Ambient Temperature Drift: Includes the combined effects of zero and space drift over temperature and is better than $\pm 50\text{ppm}/^\circ\text{C}$ ($\pm 0.0050\%/^\circ\text{C}$) over the ambient temperature range for reference test conditions (see Input Specifications).

Output DAC Resolution: Output is driven by a 16-bit Voltage DAC, Maxim MAX5216GUA+, with a 2.5V reference, and driving a universal current/voltage output driver. The output resolution per output range is indicated below. The effective I/O resolution of the transmitter will be the lowest resolution of the input, and the output D/A relative to the programmed I/O ranges.

Output Range	Output Resolution, 1 LSB, % of Span
-10V to +10V	1 part in 62558, $319.703\mu\text{V}$, 0.001598%
0 to +10V	1 part in 59293, $168.362\mu\text{V}$, 0.001684%
-5V to +5V	1 part in 31278, $319.714\mu\text{V}$, 0.003197%
0 to +5V	1 part in 60414, $82.7623\mu\text{V}$, 0.001655%
$\pm 20\text{mA}$	1 part in 62400, $0.64103\mu\text{A}$, 0.001603%
0 to +20mA	1 part in 58732, $0.34053\mu\text{A}$, 0.001703%
+4mA to +20mA	1 part in 46984, $0.34054\mu\text{A}$, 0.002128%

Output Response Time: Varies with input filter level for a step change in the input signal (also varies with output load). Note: The ADC requires two samples to fully characterize the input signal (see Input Sampling Rate).

Filter Level	Response Time (Typical)
None	32ms
Low Filter	50ms
Medium Filter	160ms
High Filter	1210ms

USB Interface



IMPORTANT:

The input of this transmitter is isolated from its output and can be connected to grounded or un-grounded input sensors. However, the transmitter’s input circuit ground is connected in common to the USB power/signal/shield ground. This will in-turn make a connection to earth ground at the PC when directly connected to the USB port of a PC without using an isolator. Failure to connect USB without isolation would connect the 1.25V input bias supply to input ground if the sensor is also earth grounded. This will interfere with operation and cause the output to shift. For this reason, USB isolation is strongly recommended when connecting to a PC. Otherwise, in the absence of USB isolation, and when connected to a grounded input sensor, a battery powered laptop could be used to connect to the transmitter, as the laptop does not normally connect to earth ground.

Transmitter includes a USB socket for temporary connection to a PC or laptop for the purpose of setup and reconfiguration. USB isolation is required when connected to a grounded input sensor (see “IMPORTANT” note on the left). During reconfiguration and calibration, the transmitter receives power from its power connection (via DIN rail bus or power terminal), but not USB. As such, power must be connected when the transmitter is connected to USB.

CAUTION: Do not attempt to connect USB in a hazardous environment. Transmitter should be configured and calibrated in a safe environment only.

Data Rate: USB v1.1 full-speed only, at 12Mbps. Up to 32K commands per second. USB 2.0 compatible.

Transient Protection: Transient voltage suppression on USB power and data lines.

USB Connector: 5-pin, Mini USB B-type socket, Hirose Electric UX60-MB-5S8.

Pin	Definition
1	+5V Power
2	Differential Data (+)
3	Differential Data (-)
4	NC – Not Connected
5 ¹	Power Ground (Connects to Signal Ground via ferrite bead)
SHLD ¹	Signal Ground (Connects directly to Signal Ground)

¹**Note:** Most Host Personal Computers (except battery powered laptops) will connect earth ground to the USB shield and signal ground.

Cable Length/Connection Distance: 5.0 meters maximum.

Driver: No special drivers required. Uses the built-in USB Human Interface Device (HID) drivers of the Windows Operating System (Windows XP or later versions only).

Power

CAUTION:

Do not exceed 36VDC peak to avoid damage to the transmitter. Terminal voltage at or above 12V minimum must be maintained across the transmitter during operation.

Power Supply (Connect at TB4 or via DIN Rail Bus): 12–32VDC SELV (Safety Extra Low Voltage), 1.3W maximum. Observe proper polarity. Reverse voltage protection is included. Current draw varies with power voltage as follows (currents indicated assume a current output is driving 21mA into the load).

Power Supply Voltage	TT335-0700 Current
12V	97mA Typical / 110mA Max
15V	73mA Typical / 80mA Max
24V	47mA Typical / 52mA Max
32V	36mA Typical / 40mA Max

Power Supply Effect: Less than ±0.001% of output span effect per volt DC change.

Enclosure & Physical

General purpose plastic enclosure for mounting on 35mm "T-type" DIN rail.

Dimensions: Width = 17.5mm (0.69 inches), Length = 114.5mm (4.51 inches), Depth = 99.0mm (3.90 inches). Refer to Mechanical Dimensions drawing.

I/O Connectors: Removable plug-in type terminal blocks rated for 12A/250V; AWG #26-14, stranded or solid copper wire.

Program Connector: USB Mini B-type, 5-pin. See USB Interface.

Case Material: Self-extinguishing polyamide, UL94 V-0 rated, color light gray. General purpose NEMA Type 1 enclosure.

Circuit Board: Military grade fire-retardant epoxy glass per IPC-4101/98.

DIN-Rail Mounting: Transmitter is normally mounted to 35x15mm, T-type DIN rails. Refer to the DIN Rail Mounting & Removal section for more details.

Shipping Weight: 0.5 pounds (0.22 Kg) packed.

Environmental

These limits represent the minimum requirements of the applicable standard, but this product has typically been tested to comply with higher standards in some cases.

Operating Temperature: -40°C to +80°C (-40°F to +176°F).

Storage Temperature: -40°C to +85°C (-40°F to +185°F).

Relative Humidity: 5 to 95%, non-condensing.

Isolation: Input/USB, output, and power circuits are all isolated from each other for common-mode voltages up to 250VAC, or 354V DC off DC power ground, on a continuous basis (will withstand 1500VAC dielectric strength test for one minute without breakdown). Complies with test requirements of ANSI/ISA-82.01-1988 for voltage rating specified.

Installation Category: Suitable for installation in a Pollution Degree 2 environment with an Installation Category (Over-voltage Category) II rating per IEC 1010-1 (1990).

Shock & Vibration Immunity: Conforms to: IEC 60068-2-6: 10-500 Hz, 4G, 2 Hours/axis, for sinusoidal vibration; IEC 60068-2-64: 10-500 Hz, 4G-rms, 2 Hours/axis, for random vibration, and IEC 60068-2-27: 25G, 11ms half-sine, 18 shocks at 6 orientations, for mechanical shock.

Electromagnetic Compatibility (EMC)

Minimum Immunity per BS EN 61000-6-1

1. Electrostatic Discharge Immunity (ESD), per IEC 61000-4-2
2. Radiated Field Immunity (RFI), per IEC 61000-4-3
3. Electrical Fast Transient Immunity (EFT), per IEC 61000-4-4
4. Surge Immunity, per IEC 61000-4-5
5. Conducted RF Immunity (CRFI), per IEC 61000-4-6

This is a Class B Product with Emissions per BS EN 61000-6-3

1. Enclosure Port, per CISPR 16
2. Low Voltage AC Mains Port, per CISPR 14, 16
3. DC Power Port, per CISPR 16
4. Telecom / Network Port, per CISPR 22

Agency Approvals

Electromagnetic Compatibility (EMC): CE marked, per EMC Directive 2004/108/EC.

FCC Conformity: This device complies with Part 15, Class B of the FCC rules.

Safety Approvals: UL Listed (USA & Canada). Hazardous Locations – Class I, Division 2, Groups A, B, C, D Hazardous Location or Nonhazardous Locations only. These devices are open-type devices that are to be installed in an enclosure suitable for the environment.

ATEX/IECEX Certified: Model TT335-0700 is ATEX/IECEX Certified for Explosive Atmospheres per ATEX Directive 2014/34/EU which complies with standards EN IEC 60079-0:2018, EN IEC 60079-7:2015 +A1:2018, IEC 60079-0 Edition 7, and IEC 60079-7 Edition 5.1.

⊕ II 3 G Ex ec IIC T4 Gc -40°C ≤ Ta ≤ +80°C
DEMKO 15 ATEX 1561X IECEx UL 18.0091X

X = Special Conditions

- 1) The equipment shall only be used in an area of not more than pollution degree 2, as defined in EN/IEC 60664-1.
- 2) The equipment shall be installed in an enclosure that provides a degree of protection not less than IP 54 and only accessible with the use of a tool in accordance with EN/IEC 60079-0.
- 3) Transient protection shall be provided that is set at a level not exceeding 140 % of the peak rated voltage value at the supply terminals to the equipment.

Reliability Prediction

MTBF (Mean Time Between Failure): MTBF in hours using MIL-HDBK-217F, FN2. *Per MIL-HDBK-217, Ground Benign, Controlled, G_BG_C*

Temp	MTBF (Hours)	MTBF (Years)	Failure Rate (FIT)
25°C	1,341,495	153.1	745
40°C	883,673	100.9	1,132

Configuration Controls

Software Configuration Only via USB

This transmitter drives an analog output current or voltage proportional to a sensor input. No switches or potentiometers are used to make adjustments to this transmitter. Its behavior as an isolated signal amplifier/transducer is determined via programmed variables set using a temporary USB connection to a host computer or laptop running a Windows-compatible configuration software program specific to the transmitter model. This software provides the framework for digital control of all configuration and calibration parameters, and this information is stored in non-volatile memory.

Refer to Operation Step-By-Step in the Technical Reference section of this manual for detailed information on available software control of this transmitter.

REVISION HISTORY

The following table details the revision history for this document:

Release Date	Version	EGR/DOC	Description of Revision
27-SEP-2013	A	JMO/KLK	Initial Acromag release.
16-OCT-2013	B	JMO/KLK	Updated Simplified Diagram; Updated Input Reference Test Conditions (was: Four-wire configuration).
12-NOV-2013	C	JMO/KLK	Added MTBF Reliability Prediction
30-NOV-2013	D	JMO/ARP	Table 1 – Input Ranges & Accuracy Note 1 modified.
16-DEC-2013	E	JEB/ARP	Removed P.O. Box from address.
21-FEB-2014	F	CAP/ARP JMO/ARP	<ul style="list-style-type: none"> • Added cULus Mark to this model (removed pending). • Updated Configuration section: Added instructions for new Input Ranges. • Updated Input Range table: Added resistance Input Ranges 25, 900, 2250, and 4500 Ohms. Updated accuracy. • Updated Input Range table Note 1: Low input resistance doesn't trigger break detect when Resistance Input Type selected. • Updated Input Resolution table: Added data for new Input Ranges.
31-JUL-2014	G	CAP/ARP	Added UL caution symbols / statements
4-NOV-2014	H	JEB/ARP	Added Acromag Agility™ Config Tool Quick Guide. Added USB OTG cable in Accessories Section.
15-OCT-2015	J	CAP/MJO	Added ATEX symbols / statements.
19-AUG-2016	K	CAP/MJO	Corrected "Circuit Board" specification.
27-NOV-2018	L	CAP/ARP	Added IECEx / FCC statements.
18 NOV 2022	M	CAP/AMM	Update EN IEC Standards. Changed ATEX/IECEx protection method from "nA" to "ec".