



**Series PMC483, APC483, AcPC483
Counter Timer Board**

USER'S MANUAL

**ACROMAG INCORPORATED
30765 South Wixom Road
Wixom, MI 48393-2417 U.S.A.**

**Tel: (248) 295-0310
Fax: (248) 624-9234**

**Copyright 2004, Acromag, Inc., Printed in the USA.
Data and specifications are subject to change without notice.**

8500705E

TABLE OF CONTENTS

The information of this manual may change without notice. Acromag makes no warranty of any kind with regard to this material, including, but not limited to, the implied warranties of merchantability and fitness for a particular purpose. Further, Acromag assumes no responsibility for any errors that may appear in this manual and makes no commitment to update, or keep current, the information contained in this manual. No part of this manual may be copied or reproduced in any form without the prior written consent of Acromag, Inc.

IMPORTANT SAFETY CONSIDERATIONS

You must consider the possible negative effects of power, wiring, component, sensor, or software failure in the design of any type of control or monitoring system. This is very important where property loss or human life is involved. It is important that you perform satisfactory overall system design and it is agreed between you and Acromag, that this is your responsibility.

1.0 General Information

KEY 483 COUNTER/TIMER FEATURES.....	4
KEY 483 Digital I/O FEATURES.....	5
PCI INTERFACE FEATURES.....	6
SIGNAL INTERFACE PRODUCTS.....	6
Board DLL Control Software.....	7
Board VxWORKS Software.....	7
Board QNX Software.....	7

2.0 PREPARATION FOR USE

UNPACKING AND INSPECTION.....	8
CARD CAGE CONSIDERATIONS.....	8
BOARD CONFIGURATION.....	8
Default Hardware Jumper Configuration.....	8
Front Panel Field I/O Connector.....	9
Rear J4 Field I/O Connector (PMC Only).....	10
Non-Isolation Considerations.....	11

3.0 PROGRAMMING INFORMATION

PCI CONFIGURATION ADDRESS SPACE.....	12
Configuration registers.....	13
MEMORY MAP.....	14
Interrupt Register.....	16
Interrupt Status/Clear Register.....	17
Digital Registers.....	18
Interrupt Type Configuration Registers.....	19
Interrupt Polarity Registers.....	19
Counter Trigger Register.....	19
Counter Stop Register.....	20
Counter Readback Register.....	21
Counter Constant A Register.....	21
Counter Constant B Register.....	21
COUNTER CONTROL REGISTER.....	21
Quadrature Position Measurement.....	22
Pulse Width Modulation.....	24
Watchdog Timer Operation.....	26
Event Counting Operation.....	28
Frequency Measurement Operation.....	30
Input Pulse Width Measurement.....	32
Input Period Measurement.....	34
One-Shot Pulse Mode.....	36
PROGRAMMING EXAMPLES.....	38
Quadrature Position Measurement Example..	38

TABLE OF CONTENTS

Pulse Width Modulation Example..... 39
 Watchdog Timer Operation Example..... 40
 Event Counting Operation Example..... 42
 Frequency Measurement Operation Example. 43
 Input Pulse Width Measurement Example..... 44
 Input Period Measurement Example..... 46
 One-Shot Pulse Mode Example..... 47

4.0 THEORY OF OPERATION

PCI INTERFACE LOGIC..... 50
 COUNTER TIMER CONTROL LOGIC..... 50
 DIGITAL INPUT/OUTPUT LOGIC..... 50

5.0 SERVICE AND REPAIR

SERVICE AND REPAIR ASSISTANCE..... 51
 PRELIMINARY SERVICE PROCEDURE..... 51
 WHERE TO GET HELP..... 51

6.0 SPECIFICATIONS

PHYSICAL..... 52
 ENVIRONMENTAL..... 52
 DIGITAL INPUT/OUTPUT..... 53
 BOARD CRYSTAL OSCILLATOR..... 55
 PCI LOCAL BUS INTERFACE..... 55

APPENDIX

CABLE: MODEL 5028-432..... 56
 TERMINATION PANEL: MODEL 5025-288..... 56

DRAWINGS

4501-953 483 BLOCK DIAGRAM..... 57
 4501-954 483 RESISTOR LOCATION..... 58
 4501-919 CABLE 5028-432 (SHIELDED)..... 59
 4501-920 TERMINATION PANEL 5025-288..... 60
 REVISION HISTORY 61

Trademarks are the property of their respective owners.

1.0 GENERAL INFORMATION

The 483 board has up to four 16-bit and four 32-bit multifunction counter/timers. In addition, 16 digital input/output channels are provided (12 digital input/output channels for PMC483R(E) models only).

The 16 digital input/output channels can be programmed as input or output on a channel basis. All input channels can be enabled for change of state, low, or high level transition interrupts.

Four independent 16-bit and four 32-bit multifunction counters/timers are also provided. The counter can be configured for quadrature position measurement, pulse width modulated output, watchdog timer, event counter, frequency measurement, pulse width measurement, period measurement, or one shot pulse output.

Table 1.1: The 483 boards are available in standard and extended temperature ranges

MODEL	Board Form Factor	16-bit, 32-bit Counters	I/O Type	OPERATING TEMPERATURE RANGE
PMC483	PCI Mezzanine Card	Four 16-Bit Four 32-Bit	TTL RS422	0°C to +70°C
PMC483R	PCI Mezzanine Card	Four 16-Bit Four 32-Bit	TTL RS422	0°C to +70°C
APC483	Short PCI	Four 16-Bit Four 32-Bit	TTL RS422	0°C to +70°C
AcPC483	3U CompactPCI	Four 16-Bit Four 32-Bit	TTL RS422	0°C to +70°C
PMC483E	PCI Mezzanine Card	Four 16-Bit Four 32-Bit	TTL RS422	-40°C to +85°C
PMC483RE	PCI Mezzanine Card	Four 16-Bit Four 32-Bit	TTL RS422	-40°C to +85°C
APC483E	Short PCI	Four 16-Bit Four 32-Bit	TTL RS422	-40°C to +85°C
AcPC483E	3U CompactPCI	Four 16-Bit Four 32-Bit	TTL RS422	-40°C to +85°C

Note: PMC483R and PMC483RE are rear field I/O models, only. All other models have front I/O.

KEY 483 COUNTER/TIMER FEATURES

- **TTL and RS422 I/O** – Mixed TTL and RS422 I/O options are available on the 483 models. The four 16-bit counters are TTL controlled while the four 32-bit counters are RS422 I/O controlled. Only RS422 I/O is available on the 484 models. TTL is only available on the 482 models.
- **Quadrature Position Measurement** – Three input signals can be used to determine bi-direction motion. The sequence of logic high pulses for two input signals, A and B, indicate direction and a third signal (index) is used to initialize the counter. X1, X2, and X4 decoding is also implemented. X1 decoding executes one count per duty cycle of the A and B signals, while X2, and X4 execute two and four counts per duty cycle respectively.
- **Pulse Width Modulation** – Each counter can be programmed for pulse width modulation. The duration of the logic high and low levels of the output signal can be independently controlled. An external gate signal can also be used to start/stop generation of the output signal.

- **Watchdog Timer** – Each counter can be configured as a countdown timer for implementation as a watchdog timer. A gate-off signal is available for use to stop the count down operation. Interrupt generation upon a countdown to zero condition is available.
- **Event Counter** – Each counter can be configured to count input pulses or events. A gate-off signal is provided to control count-up or count down with each event. Interrupt generation upon programmed count condition is available.
- **Frequency Measurement** – Each counter can be configured to count how many active edges are received during a period defined by an external count enable signal. An interrupt can be generated upon measurement complete.
- **Pulse-Width or Period Measurement** – Each counter can be configured to measure pulse-width or waveform period. In addition, an interrupt can be generated upon measurement complete.
- **One-Shot and Repetitive One-Shot** – A one-shot pulse waveform may also be generated by each counter. The duration of the pulse and the delay until the pulse goes active is user programmable. A repetitive one-shot can be initiated with repetitive trigger pulses.
- **Programmable Interface Polarity** – The polarities of the counter's external trigger, input, and output pins are programmable for active high or low operation. These counter control signals are available through the board's 68-pin SCSI field connector.
- **Internal or External Triggering** – A software or hardware trigger is selectable to initiate quadrature position measurement, pulse width modulation, watchdog countdown, event counting, frequency measurement, pulse-width measurement, period measurement, or one shot.
- **16 Digital Input/Output Channels** – Interface with up to 16 input/output channels which can be configured as input or output on an individual channel basis. Rear I/O models only provided 12 digital I/O channels.
- **TTL Compatible Thresholds** – Input and output signal thresholds are at TTL levels.
- **Programmable Change of State/Level Interrupts** – Interrupts are software programmable for any bit Change-Of-State or level on all 16 channels.
- **Power Up and System Reset is Failsafe** – For safety, the digital channels are configured for input upon power-up.

KEY 483 COUNTER/TIMER FEATURES

KEY 483 DIGITAL I/O FEATURES

PCI INTERFACE FEATURES

- **High density** - Target board.
- **Field Connections** – All counter/timer, digital I/O, and power connections are made through a single 68-pin SCSI front panel I/O connector. Models PMC483R and PMC483RE, only use a 64 pin rear I/O connector.
- **32, 16, 8-bit I/O** - Register Read/Write is performed through data transfer cycles in the PCI memory space. All registers can be accessed via 32, 16, or 8-bit data transfers.
- **Compatibility** – Complies to PCI Local Bus Specification Revision 2.2. Provides one multifunction interrupt. Board is 5V signaling compliant and 3.3V signaling tolerant.

SIGNAL INTERFACE PRODUCTS

The following signal interface products are for front I/O models, which are accessed via a 68 pin SCSI-3 front panel connector.

Cables and a termination panel are also available to interface with this board.

Cable:

Model 5028-432: A 2-meter, round 68 conductor shielded cable with a male SCSI-3 connector at both ends and 34 twisted pairs. The cable is used for connecting the board to Model 5025-288 termination panels. For optimum performance, use the shortest possible length of shielded input cable.

Termination Panel:

Model 5025-288: DIN-rail mountable panel provides 68 screw terminals for universal field I/O termination. Connects to Acromag board, via SCSI-3 to twisted pair cable described above.

See the Appendix for further information on these products.

Acromag provides a software product (sold separately) to facilitate the development of Windows (98/Me/NT4/2000/XP®) applications accessing Acromag PMC I/O board products, PCI I/O Cards, and CompactPCI I/O Cards. This software (Model PCISW-API-WIN) consists of low-level drivers and Windows 32 Dynamic Link Libraries (DLLs) that are compatible with a number of programming environments including Visual C++™, Visual Basic®, Borland C++ Builder® and others. The DLL functions provide a high-level interface to boards eliminating the need to perform low-level reads/writes of registers, and the writing of interrupt handlers.

BOARD DLL CONTROL SOFTWARE

Acromag provides a software product (sold separately) consisting of board VxWorks® software. This software (Model PMCSW-API-VXW) is composed of VxWorks® (real time operating system) libraries for all Acromag PMC I/O board products, PCI I/O Cards, and CompactPCI I/O Cards. The software is implemented as a library of "C" functions which link with existing user code to make possible simple control of all Acromag PCI boards.

BOARD VxWORKS SOFTWARE

Acromag provides a software product (sold separately) consisting of board QNX® software. This software (Model PCISW-API-QNX) is composed of QNX® (real time operating system) libraries for all Acromag PMC I/O board products, PCI I/O Cards, and CompactPCI I/O Cards. The software is implemented as a library of "C" functions which link with existing user code to make possible simple control of all Acromag PCI boards.

BOARD QNX SOFTWARE

2.0 PREPARATION FOR USE UNPACKING AND INSPECTION



WARNING: This board utilizes static sensitive components and should only be handled at a static-safe workstation.

CARD CAGE CONSIDERATIONS

IMPORTANT: Adequate air circulation must be provided to prevent a temperature rise above the maximum operating temperature.

BOARD CONFIGURATION

Default Hardware Jumper Configuration

Upon receipt of this product, inspect the shipping carton for evidence of mishandling during transit. If the shipping carton is badly damaged or water stained, request that the carrier's agent be present when the carton is opened. If the carrier's agent is absent when the carton is opened and the contents of the carton are damaged, keep the carton and packing material for the agent's inspection.

For repairs to a product damaged in shipment, refer to the Acromag Service Policy to obtain return instructions. It is suggested that salvageable shipping cartons and packing material be saved for future use in the event the product must be shipped.

This board is physically protected with packing material and electrically protected with an anti-static bag during shipment. However, it is recommended that the board be visually inspected for evidence of mishandling prior to applying power.

Refer to the specifications for loading and power requirements. Be sure that the system power supplies are able to accommodate the power requirements of the carrier/CPU board, plus the installed boards, within the voltage tolerances specified.

Adequate air circulation must be provided to prevent a temperature rise above the maximum operating temperature and to prolong the life of the electronics. If the installation is in an industrial environment and the board is exposed to environmental air, careful consideration should be given to air-filtering.

Remove power from the system before installing board, cables, termination panels, and field wiring.

The board may be configured differently, depending on the application. When the board is shipped from the factory, it is configured as follows:

- J3 is open. Plus 3.3 volts is provided from an on board regulator.
- The default configuration of the programmable software control register bits at power-up are described in section 3.
- The control registers must be programmed to the desired configuration before starting data input or output operation.

The front panel connector provides the field I/O interface connections. It is a SCSI-3 68-pin female connector (AMP 787082-7 or equivalent) employing latch blocks and 30 micron gold in the mating area (per MIL-G-45204, Type II, Grade C). Connects to Acromag termination panel 5025-288 from the front panel via round shielded cable (Model 5028-432).

Front Panel Field I/O Connector

Table 2.1: Board Field I/O Pin Connections

Pin Description		Pin	Pin Description		Pin
RS422 (32-Bit)			RS422 (32-Bit)		
IN1_A+		1	IN1_B+		36
IN1_A-		2	IN1_B-		37
IN2_A+		3	IN2_B+		38
IN2_A-		4	IN2_B-		39
IN3_A+		5	IN3_B+		40
IN3_A-		6	IN3_B-		41
IN4_A+		7	IN4_B+		42
IN4_A-		8	IN4_B-		43
TTL			TTL		
16-bit	32-bit		16-bit	32-bit	
IN5_A		9	IN5_B		44
IN6_A	Not Used	10	IN6_B	Not Used	45
IN7_A		11	IN7_B		46
IN8_A	Not Used	12	IN8_B	Not Used	47
COMMON		13			
RS422 (32-Bit)			RS422 (32-Bit)		
IN1_C+		14	OUT1+		48
IN1_C-		15	OUT1-		49
IN2_C+		16	OUT2+		50
IN2_C-		17	OUT2-		51
IN3_C+		18	OUT3+		52
IN3_C-		19	OUT3-		53
IN4_C+		20	OUT4+		54
IN4_C-		21	OUT4-		55
TTL			TTL		
16-bit	32-bit		16-bit	32-bit	
IN5_C		22	OUT5		56
IN6_C	Not Used	23	OUT6	Not Used	57
IN7_C		24	OUT7		58
IN8_C	Not Used	25	OUT8	Not Used	59
COMMON		26	Digital CH8		60
Digital CH0		27	Digital CH9		61
Digital CH1		28	Digital CH10		62
Digital CH2		29	Digital CH11		63
Digital CH3		30	Digital CH12		64
Digital CH4		31	Digital CH13		65
Digital CH5		32	Digital CH14		66
Digital CH6		33	Digital CH15		67
Digital CH7		34	COMMON		68
COMMON		35			

The board has four RS422 32-bit and four TTL 16-bit counters available. Two 16-bit counters can be configured as one 32-bit counter. If counters 5 and 6 were configured as a 32-bit counter, then the input and output signals labeled IN5 and OUT5 are used while signals IN6 and OUT6 are not used. Similarly counters 7 and 8 can also be configured as 32-bit counters. The input and output signals labeled IN7 and OUT7 are used while signals IN8 and OUT8 are not used.

Table 2.2: Board Rear Field I/O Pin Connections

The board has four RS422 32-bit and four TTL 16-bit counters available. Two 16-bit counters can be configured as one 32-bit counter. If counters 5 and 6 were configured as a 32-bit counter, then the input and output signals labeled IN5 and OUT5 are used while signals IN6 and OUT6 are not used. Similarly counters 7 and 8 can also be configured as 32-bit counters. The input and output signals labeled IN7 and OUT7 are used while signals IN8 and OUT8 are not used.

Pin Description		Pin	Pin Description		Pin
RS422 (32-Bit)			RS422 (32-Bit)		
IN1_A+		1	IN1_B+		36
IN1_A-		2	IN1_B-		37
IN2_A+		3	IN2_B+		38
IN2_A-		4	IN2_B-		39
IN3_A+		5	IN3_B+		40
IN3_A-		6	IN3_B-		41
IN4_A+		7	IN4_B+		42
IN4_A-		8	IN4_B-		43
TTL			TTL		
16-bit	32-bit		16-bit	32-bit	
IN5_A		9	IN5_B		44
IN6_A	Not Used	10	IN6_B	Not Used	45
IN7_A		11	IN7_B		46
IN8_A	Not Used	12	IN8_B	Not Used	47
COMMON		13			
RS422 (32-Bit)			RS422 (32-Bit)		
IN1_C+		14	OUT1+		48
IN1_C-		15	OUT1-		49
IN2_C+		16	OUT2+		50
IN2_C-		17	OUT2-		51
IN3_C+		18	OUT3+		52
IN3_C-		19	OUT3-		53
IN4_C+		20	OUT4+		54
IN4_C-		21	OUT4-		55
TTL			TTL		
16-bit	32-bit		16-bit	32-bit	
IN5_C		22	OUT5		56
IN6_C	Not Used	23	OUT6	Not Used	57
IN7_C		24	OUT7		58
IN8_C	Not Used	25	OUT8	Not Used	59
COMMON		26	Digital CH8		60
Digital CH0		27	Digital CH9		61
Digital CH1		28	Digital CH10		62
Digital CH2		29	Digital CH11		63
Digital CH3		30	No Connection		64
Digital CH4		31			
Digital CH5		32			
Digital CH6		33			
Digital CH7		34			
COMMON		35			

Note: On rear I/O models, Digital CH12 - CH15 are not connected to J4.

The board is non-isolated, since there is electrical continuity between the logic and field I/O grounds. As such, the field I/O connections are not isolated from the carrier/CPU board and backplane. Care should be taken in designing installations without isolation to avoid noise pickup and ground loops caused by multiple ground connections. This is particularly important for analog inputs and outputs when a high level of accuracy/resolution is needed.

Non-Isolation Considerations

3.0 PROGRAMMING INFORMATION

This Section provides the specific information necessary to program and operate the board.

This board is a PCI Specification version 2.2 compliant PCI bus target only board.

The PCI bus is defined to address three distinct address spaces: I/O, memory, and configuration space. This board can be accessed via the PCI bus memory space and configuration spaces, only.

The PCI card's configuration registers are initialized by system software at power-up to configure the card. The board is a Plug-and-Play PCI card. As a Plug-and-Play card the board's base address and system interrupt request line are not selected via jumpers but are assigned by system software upon power-up via the configuration registers. A PCI bus configuration access is used to read/write the PCI card's configuration registers.

PCI Configuration Address Space

When the computer is first powered-up, the computer's system configuration software scans the PCI bus to determine what PCI devices are present. The software also determines the configuration requirements of the PCI card.

The system software accesses the configuration registers to determine how many blocks of memory space the carrier requires. It then programs the board's configuration registers with the unique memory base address.

The configuration registers are also used to indicate that the board requires an interrupt request line. The system software then programs the configuration registers with the interrupt request line assigned to the board.

Since this board is relocatable and not fixed in address space, this device driver must use the mapping information stored in the board's Configuration Space registers to determine where the board is mapped in memory space and which interrupt line will be used.

The PCI specification requires software driven initialization and configuration via the Configuration Address space. This board provides 256 bytes of configuration registers for this purpose. It contains the configuration registers, shown in Table 3.1, to facilitate Plug-and-Play compatibility.

The Configuration Registers are accessed via the Configuration Address and Data Ports. The most important Configuration Registers are the Base Address Registers and the Interrupt Line Register which must be read to determine the base address assigned to the board and the interrupt request line that goes active on a board interrupt request.

**CONFIGURATION
REGISTERS**

Table 3.1 Configuration Registers

Reg. Num.	D31	D24	D23	D16	D15	D8	D7	D0
0	Device ID=4A42				Vendor ID= 16D5			
1	Status				Command			
2	Class Code=118000						Rev ID=00	
3	BIST		Header		Latency		Cache	
4	32-bit Memory Base Address for 4K-Byte Block							
5 : 10	Not Used							
11	Subsystem ID=0000				Subsystem Vendor ID=0000			
12	Not Used							
13,14	Reserved							
15	Max_Lat		Min_Gnt		Inter. Pin		Inter. Line	

MEMORY MAP

This board is allocated a 4K byte block of memory that is addressable in the PCI bus memory space to control the board's multiple functions. Three types of information are stored in the memory space: control, status, and data.

The memory space address map for the board is shown in Table 3.2. Note that the base address for the board in memory space must be added to the addresses shown to properly access the board's registers. Register accesses as 32, 16, and 8-bit in memory space are permitted.

Table 3.2: Memory Map

Base Addr+	D31	D16	D15	D00	Base Addr+
03	Not Used ¹		Interrupt Register		00
07	Counters Interrupt Status/Clear Reg.		Digital I/O Interrupt Status/Clear Reg.		04
0B	Not Used ¹		16-bit Digital I/O Register		08
0F	Not Used ¹		16-bit Digital I/O Direction Register		0C
13	Not Used ¹		Digital I/O Interrupt Enable Register		10
17	Not Used ¹		Digital I/O Interrupt Type Register		14
1B	Not Used ¹		Digital I/O Interrupt Polarity Register		18
1F	Counter Stop Register		Counter Trigger Register		1C
23	Counter 1 Control Register 32-bit Counter				20
27	Not Used ¹				24
2B	Counter 2 Control Register 32-bit Counter				28
2F	Not Used ¹				2C
33	Counter 3 Control Register 32-bit Counter				30
37	Not Used ¹				34
3B	Counter 4 Control Register 32-bit Counter				38
3F	Not Used ¹				3C
43	Counter 5 Control Register (32-bit Counter Control Register) ²				40
47	Counter 6 Control Register				44
4B	Counter 7 Control Register (32-bit Counter Control Register) ²				48
4F	Counter 8 Control Register				4C

1. The board will return 0 for all addresses that are "Not Used".

2. The board has four RS422 32-bit counters and four TTL 16-bit counters available. Via counter 5 control register, 16-bit counters 5 and 6 can be configured as one 32-bit counter. Counters 7 and 8 can also be configured as a 32-bit counter via counter 7 control register.

MEMORY MAP

53	Counter 1 Read Back Register		50
57	Counter 2 Read Back Register		54
5B	Counter 3 Read Back Register		58
5F	Counter 4 Read Back Register		5C
63	Counter 6 Read Back Register	Counter 5 Read Back Register	60
67	Counter 8 Read Back Register	Counter 7 Read Back Register	64
6B	Counter 1 Constant A Register		68
6F	Counter 2 Constant A Register		6C
73	Counter 3 Constant A Register		70
77	Counter 4 Constant A Register		74
7B	Counter 6 Constant A Register	Counter 5 Constant A Register	78
7F	Counter 8 Constant A Register	Counter 7 Constant A Register	7C
83	Counter 1 Constant B Register		80
87	Counter 2 Constant B Register		84
8B	Counter 3 Constant B Register		88
8F	Counter 4 Constant B Register		8C
93	Counter 6 Constant B Register	Counter 5 Constant B Register	90
97	Counter 8 Constant B Register	Counter 7 Constant B Register	94
9B	Not Used ¹		98
↓	↓		↓
FFF	Not Used ¹		FFC

When a 32-bit counter is enabled, the readback and constant registers of the two 16-bit counters that makeup the 32-bit counter become 32-bit register values.

This memory map reflects byte accesses using the "Little Endian" byte ordering format. Little Endian uses even-byte addresses to store the low-order byte. The Intel x86 family of microprocessors uses "Little Endian" byte ordering. Big Endian is the convention used in the Motorola 68000 microprocessor family and is the VMEbus convention. In Big Endian, the lower-order byte is stored at odd-byte addresses.

INTERRUPT REGISTER**Interrupt Register (Read/Write) – (Base +00H)**

This read/write register is used to enable board interrupt operation, determine the pending status of interrupts, and release pending interrupts.

The function of each of the interrupt register bits is described in Table 3.3. This register can be read or written with either 8-bit, 16-bit, or 32-bit data transfers. A power-up or system reset sets all interrupt register bits to 0.

Table 3.3: *Interrupt Register*

BIT	FUNCTION
0	Board Interrupt Enable Bit. (Read/Write Bit) 0 = Disable Interrupt 1 = Enable Interrupt If enabled via this bit an interrupt request from the board will be issued to the system upon any of its interrupt conditions. The interrupt request will remain active until the interrupt release bit is set, or by disabling interrupts via this bit.
1	Board Interrupt Pending Status Bit. (Read Only Bit) 0 = Interrupt Not Pending 1 = Interrupt Pending This bit can be read to determine the interrupt pending status of the board. When this bit is logic "1" an interrupt is pending, and will cause an interrupt request if bit-0 of the register is set. When this bit is a logic "0" an interrupt is not being requested. Once the bit is in the pending status it will remain until the pending interrupt is removed via the source of the interrupt. This bit will remain active even if interrupts are disabled via bit-0. When this bit is set, the pending interrupt can originate from any of the counter timers or the 16 digital I/O channels (12 digital I/O channels for rear I/O Models). An interrupt can still be caused on channels 12 – 15 by writing to the digital I/O register. To identify source of the pending interrupt the following register bits must be read at base address plus 04H. <ul style="list-style-type: none"> • Bits-15 to 0 identify a pending Digital I/O Interrupt • Bits-27 to 16 identify a pending Counter/Timer Interrupt.
2 to 13	Not Used ¹
14	Software Reset: The board is reset.
15	Not Used ¹

1. All bits labeled "Not Used" will return logic "0" when read.

Interrupt Status/Clear Register (Read/Write) – (Base + 04H)

INTERRUPT REGISTER

This read/write register is used to determine the pending status of Digital I/O and Counter/Timer interrupts, and release pending interrupts

The Digital I/O interrupt status/clear bits 15 to 0 reflect the status of each of the Digital I/O channels. The Counter/Timer interrupt status/clear bits 16 to 27 reflect the status of each of the Counter/Timers. A “1” bit indicates that an interrupt is pending for the corresponding channel or counter/timer. Digital I/O channel 0 interrupt status is identified via data bit-0 while Digital I/O channel 15 status is identified via data bit-15. The Counter/Timer and its corresponding interrupt Pending/Clear bits are as shown in Table 3.4.

BIT	FUNCTION
0	Digital I/O bit-0 Interrupt Status/Clear
1	Digital I/O bit-1 Interrupt Status/Clear
2	Digital I/O bit-2 Interrupt Status/Clear
3	Digital I/O bit-3 Interrupt Status/Clear
4	Digital I/O bit-4 Interrupt Status/Clear
5	Digital I/O bit-5 Interrupt Status/Clear
6	Digital I/O bit-6 Interrupt Status/Clear
7	Digital I/O bit-7 Interrupt Status/Clear
8	Digital I/O bit-8 Interrupt Status/Clear
9	Digital I/O bit-9 Interrupt Status/Clear
10	Digital I/O bit-10 Interrupt Status/Clear
11	Digital I/O bit-11 Interrupt Status/Clear
12	Digital I/O bit-12 Interrupt Status/Clear
13	Digital I/O bit-13 Interrupt Status/Clear
14	Digital I/O bit-14 Interrupt Status/Clear
15	Digital I/O bit-15 Interrupt Status/Clear
16	Counter/Timer 1 Interrupt Pending/Clear
17	Not Used ¹
18	Counter/Timer 2 Interrupt Pending/Clear
19	Not Used ¹
20	Counter/Timer 3 Interrupt Pending/Clear
21	Not Used ¹
22	Counter/Timer 4 Interrupt Pending/Clear
23	Not Used ¹
24	Counter/Timer 5 Interrupt Pending/Clear
25	Counter/Timer 6 Interrupt Pending/Clear
26	Counter/Timer 7 Interrupt Pending/Clear
27	Counter/Timer 8 Interrupt Pending/Clear
28-31	Not Used ¹

Table 3.4: Board Counter/Timer Interrupt Status/Clear²

1. All bits labeled “Not Used” will return logic “0” when read.
2. . The board has four RS422 32-bit counters and four TTL 16-bit counters available. 16-bit counters 5 and 6 can be configured as one 32-bit counter. Counter 7 and 8 can also be configured as one 32-bit counter. A counter configured as a 32-bit counter has its interrupt status/clear function controlled via the odd counter. For example, counter 7 and 8 when combined have their interrupt status/clear function controlled via bit-26.

- **Read** of this bit reflects the interrupt pending status of the counter timer logic.
 - 0 = Interrupt Not Pending
 - 1 = Interrupt Pending

INTERRUPT REGISTER

- **Write** a logic "1" to this bit to release a counter timer pending interrupt. A counter timer pending interrupt can also be released by disabling interrupts via bit-15 of the Counter Control registers.

A Digital I/O channel or Counter/Timer that is not interrupt enabled will never set its interrupt status flag. A Digital I/O channel or Counter/Timer interrupt can be cleared by writing a "1" to its bit position in the Interrupt Status/Clear Register (writing a "1" acts as a reset signal to clear the set state). The interrupt will be generated again; if the condition which caused the interrupt to occur remains. Writing "0" to a bit location has no effect. That is, a pending interrupt will remain pending.

DIGITAL REGISTERS

Note: Digital I/O channels 15→12 are not brought out to the rear I/O connector for the rear I/O Models.

Digital Input/Output Registers (Read/Write) - (Base + 08H)

Sixteen possible input/output channels numbered 0 through 15 may be individually accessed via these registers. The Input/Output Digital register is used to monitor/read or set/write channels 0 through 15. Channels 15 to 0 are accessed at the carrier base address +08H via data bits 15 to 0.

Channel read/write operations use 8-bit, 16-bit, or 32-bit data transfers with the lower ordered bits corresponding to the lower-numbered channels for the register of interest. All input/output channels are configured as inputs on a power-on or software reset. The unused upper 16 bits of this register are "Not Used" and will always read low (0's).

Digital Direction Control Register (Read/Write) - (Base + 0CH)

The data direction (input or output) of the 16 digital channels is selected via bits-0 to15 of this register. The data direction of channel 0 is set/controlled via bit-0 and the data direction for bit 1 is controlled via bit-1, etc. Setting a bit low configures the corresponding channel data direction for input. Setting the control bit high configures the corresponding channel data direction for output.

The default power-up state of these registers is logic low. Thus, all channels are configured as inputs on system reset or power-up. The unused upper bits of this register are "Not Used" and will always read low (0's). Reading or writing to this register is possible via 32-bit, 16-bit or 8-bit data transfers.

Note: The Interrupt Status register at the carrier's base address + offset 04H is used to monitor pending interrupts corresponding to channels 0 through 15. For example, channel 0 is monitored via data bit-0.

Digital Interrupt Enable Registers (Read/Write) - (Base + 10H)

The Interrupt Enable Registers provide a mask bit for each of the 16 channels. A "0" bit will prevent the corresponding input channel from generating an external interrupt. A "1" bit will allow the corresponding channel to generate an interrupt.

The Interrupt Enable register at the base address + offset 10H is used to control channels 0 through 15 via data bits 0 to 15. For example, channel 0 is controlled via data bit-0.

All input channel interrupts are disabled (set to "0") following a power-on or software reset. Reading or writing to this register is possible via 32-bit, 16-bit or 8-bit data transfers.

DIGITAL REGISTERS

Interrupt Type (COS or H/L) Configuration Registers (Read/Write) - (Base + 14H)

The Interrupt Type Configuration Registers determine the type of input channel transition that will generate an interrupt for each of the 16 possible interrupting channels. A "0" bit selects interrupt on level. An interrupt will be generated when the input channel level specified by the Interrupt Polarity Register occurs (i.e. Low or High level transition interrupt). A "1" bit means the interrupt will occur when a Change-Of-State (COS) occurs at the corresponding input channel (i.e. any state transition, low to high or high to low).

The Interrupt Type Configuration register at base address + offset 14H is used to control channels 0 through 15. For example, channel 0 is controlled via data bit-0. All bits are set to "0" following a reset which means that, if enabled, the inputs will cause interrupts for the levels specified by the digital input channel Interrupt Polarity Register.

Channel read or write operations use 8-bit, 16-bit, or 32-bit data transfers. Note that interrupts will not occur unless they are enabled.

Interrupt Polarity Registers (Read/Write) - (Base + 18H)

The Interrupt Polarity Register determines the level that will cause a channel interrupt to occur for each of the channels enabled for level interrupts. A "0" bit specifies that an interrupt will occur when the corresponding input channel is low (i.e. a "0" in the digital input channel data register). A "1" bit means that an interrupt will occur when the input channel is high (i.e. a "1" in the digital input channel data register). Note that no interrupts will occur unless they are enabled by the Interrupt Enable Register. Further, the Interrupt Polarity Register will have no effect if the Change-of-State (COS) interrupt type is configured by the Interrupt Type Configuration Register.

The Interrupt Polarity register at the carrier's base address + offset 18H is used to control channels 0 through 15. For example, channel 0 is controlled via data bit-0.

All bits are set to "0" following a reset which means that the inputs will cause interrupts when they are below TTL threshold (provided they are enabled for interrupt on level).

Counter Trigger Register (Write) - (Base + 1CH)

COUNTER REGISTERS

This register is used to implement software triggering for all counter timers. Writing a 1 to the counter's corresponding trigger bit of this register will cause the counter function to be triggered. Table 3.5 identifies the trigger bit location corresponding to each of the counters. The contents of this register are not stored and merely act to trigger the corresponding counters.

Triggering may be used to initiate quadrature position measurement, pulse width modulation, watchdog timer (initiates countdown), event

COUNTER REGISTERS

counting, frequency measurement, pulse-width measurement, period measurement, or one-shot.

Table 3.5: Board Counter Trigger Register

1. All bits will return logic "0" when read.

The board has four RS422 32-bit counters and four TTL 16-bit counters available. Counters 5 and 6, as well as 7 and 8 can be configured as 32-bit counters. A counter configured as a 32-bit counter has its interrupt trigger function controlled via the odd counter. For example, counter 7 and 8 when combined have their trigger function controlled via bit-10.

BIT	FUNCTION
0	Counter 1 Trigger
1	Not Used ¹
2	Counter 2 Trigger
3	Not Used ¹
4	Counter 3 Trigger
5	Not Used ¹
6	Counter 4 Trigger
7	Not Used ¹
8	Counter 5 Trigger (32-bit Counter Trigger)
9	Counter 6 Trigger
10	Counter 7 Trigger (32-bit Counter Trigger)
11	Counter 8 Trigger
12-15	Not Used ¹

Writing to this register is possible via 32-bit, 16-bit or 8-bit data transfers.

Counter Stop Register (Read/Write) - (Base + 1EH)

This register is used to stop the counters of one or a group of Counter/Timers. Writing a 1 to the counter's corresponding stop bit of this register will cause the counter to be disabled. That is, bits 2,1, and 0 of the counter control register are cleared to "000" thus disabling the counter. Table 3.6 identifies the stop bit location corresponding to each of the counters. The bits of this register are not stored and merely act to stop the corresponding counter when set logic high.

Writing to this register is possible via 32-bit, 16-bit or 8-bit data transfers.

Table 3.6: Board Counter Stop Register

1. All bits will return logic "0" when read.

The board has four RS422 32-bit counters and four TTL 16-bit counters available. Counters 5 and 6, as well as 7 and 8 can be configured as 32-bit counters. Counters configured as a 32-bit counter have their counter stop function controlled via the odd counter. For example, counter 7 and 8 when combined have their stop function controlled via bit-26.

BIT	FUNCTION
16	Counter 1 Stop
17	Not Used ¹
18	Counter 2 Stop
19	Not Used ¹
20	Counter 3 Stop
21	Not Used ¹
22	Counter 4 Stop
23	Not Used ¹
24	Counter 5 Stop (32-bit Counter Stop)
25	Counter 6 Stop
26	Counter 7 Stop (32-bit Counter Stop)
27	Counter 8 Stop
28-31	Not Used ¹

Counter Readback Register (Read Only)

COUNTER REGISTERS

This read-only register is a dynamic function register that returns the current value held in the counter. It is updated with the value stored in the internal counter each time it is read.

The internal counter is generally initialized with the value in the Counter Constant Register, and its value is incremented or decremented according to the application.

The addresses corresponding to the Counter Readback registers are given in Table 3.2. This register must be read using 32-bit long-word accesses for 32-bit enabled counters, but it may be read using 16-bit accesses for 16-bit enabled counters.

Counter Constant A Register (Write Only)

This write-only register is used to store the counter/timer constant A value (initial value) for the various counting modes. Accesses to this register are allowed on a 16-bit or 32-bit long-word basis, only. It is necessary to load the constant value into the counter in one clock cycle. Thus, for a 16-bit counter a 16-bit or 32-bit write access is required, while a 32-bit write access is required for a 32-bit counter. The addresses corresponding to the Counter Constant A registers are given in Table 3.2.

Note that the Counter Constant Registers are cleared (set to 0) following a system or software reset.

Counter Constant B Register (Read/Write)

This read/write register is used to store the counter/timer constant B value. It is necessary to load the constant value into the counter in one clock cycle. Thus, for a 16-bit counter a 16-bit or 32-bit write access is required, while a 32-bit write access is required for a 32-bit counter. The addresses corresponding to the Counter Constant B registers are given in Table 3.2.

Counter Control Register (Read/Write)

COUNTER CONTROL REGISTER

This register is used to configure counter/timer functionality. It defines the counter mode, output polarity, input polarity, clock source, debounce enable, counter size, and interrupt enable.

The board has four 32-bit and four 16-bit Counter/Timers. A pair of 16-bit counters can be grouped to form a 32-bit counter. Control register bit-14 when set high enables 32-bit counter mode. When a 32-bit counter is enabled it must be selected via control register 5 for counters 5 and 6. Likewise, control register 7 is used when counters 7 and 8 are enabled as a 32-bit counter.

The memory map addresses corresponding to the control registers are given in Table 3.2. The Counter Control Register is cleared (set to 0) following a reset, thus disabling the counter/timer. Reading or writing to this register is possible via 32-bit, 16-bit, or 8-bit data transfers.

Eight modes of operation are provided: quadrature position measurement, pulse width modulation, watchdog timer, event counting, frequency measurement, pulse width measurement, period measurement, and one-shot pulse mode. The following sections describe the features of each mode of operation and how to best use them.

COUNTER CONTROL REGISTER

Quadrature Position Measurement

The counter/timers may be used to perform position measurements from quadrature motion encoders. Bits 2 to 0 of the Counter Control Register set to logic "001" configure the counter for quadrature measurement.

A quadrature encoder can have up to three channels: A, B, and Index. When channel A leads channel B by 90° in a quadrature cycle, the counter increments. When channel B leads channel A by 90° in a quadrature cycle, the counter decrements. The number of increments or decrements per cycle depends on the type of encoding: X1, X2, or X4.

Figure 3.1: Shows a quadrature cycle and the resulting increments and decrements for X1, X2, and X4 encoding.

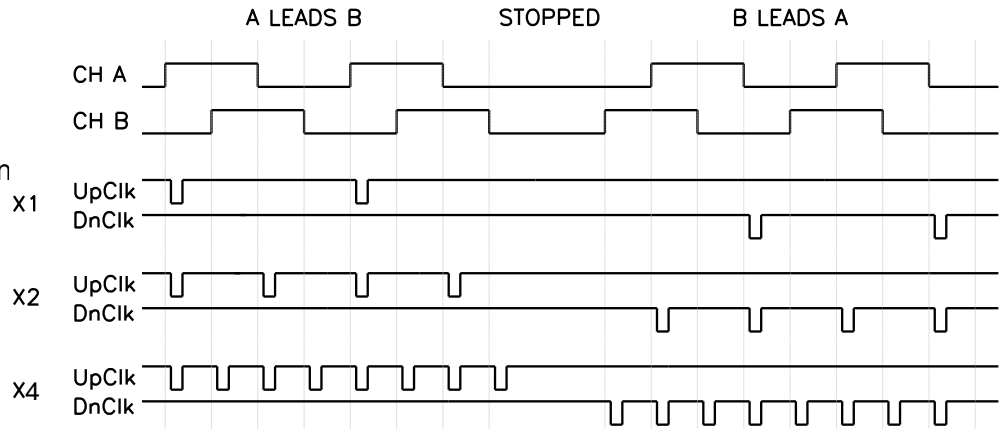

An X1 encoding increment occurs on the rising edge of channel A when channel A leads channel B. An X1 encoding decrement occurs on the falling edge of channel A when channel B leads channel A.

For X2 encoding, two increments or decrements (on each edge of channel A) result from each cycle. The counter increments when A Leads B and decrements when B leads A.

For X4 encoding, four increments or decrements (on each edge of channel A and B) result from each cycle. The counter increments when A Leads B and decrements when B leads A.

Quadrature measurement must be triggered internally via the Counter Trigger Register at the base address + offset 1CH. An initial software trigger starts quadrature position measurement operation.

InA and InB input signals are used to input the channel A and channel B input signals, respectively. The counter will increment when channel A leads channel B and will decrement when channel B leads channel A. Three rates of increments and decrements are available X1, X2, and X4 which are programmed via counter timer control register bits 5 and 4. Channel B is enabled for input by setting bit-6 to a logic "1".

InC can be used for the Index signal. Encoders that have an index channel can cause the counter to reload with the Counter Constant B value in a specified phase of the quadrature cycle. Reload can be programmed to occur in any one of the four phases in a quadrature cycle. You must ensure that the Index channel is high during at least a portion of the phase you specify for reload. The phase can be selected via the counter timer control register bits 9, 8, and 7 as seen in Table 3.7.

An interrupt can be generated upon index reload, or when the counter value equals the constant value stored in the Counter Constant A Register. Interrupts must be enabled via the interrupt enable bit-15 of the Counter Control Register and bit-0 of the Interrupt Register. The interrupt type must also be selected via bits 10 and 11 of the Counter Control Register. The interrupt will remain pending until released by setting the required bit of the Counter/Timer Interrupt Status/Clear register or setting bit-15 of the Counter Control register to "0".

COUNTER CONTROL REGISTER

QUADRATURE POSITION MEASUREMENT

The quadrature measurement value can be read from the Counter Readback Register.

Table 3.7: Counter Control Register (Quadrature Position Measurement)

1. The default state of the output pin is high (output has pullup resistor installed). Bit 3 specifies the active output polarity when the output is driven.

2. When two 16-bit counters are selected to implement a 32-bit counter the control register corresponding to the first 16-bit counter is used for control of the 32 bit counter.

Bit(s)	FUNCTION
2,1,0	Specifies the Counter Mode:
	001 Quadrature Position Measurement
3	Output Polarity (Output Pin ACTIVE Level):
	0 Active LOW (Default) ¹
	1 Active HIGH
5, 4	InA / Channel A
	00 Disabled (Default)
	01 X1 Encoding
	10 X2 Encoding
	11 X4 Encoding
6	InB / Channel B
	0 Disabled (Default)
	1 Enabled
9,8,7	InC / Index: Channel Interrupt/Reload occurs when Index signal=1 and the A & B input signals are as selected below. See Control bits 11 & 10 for additional interrupt/load control.
	000 Disabled (Default) 101, 110, and 111 also Disable
	001 A = 0 , B = 1
	010 A = 1 , B = 0
	011 A = 1 , B = 1
	100 A = 0 , B = 0
	11,10
00	No Interrupt Selected
01	Interrupt on counter equal Constant A Register.
10	Interrupt on Index and reload on Index
11	Interrupt on Index but do not reload counter on Index.
12	Not Used (bit reads back as 0)
13	Input Debounce Enable
	0 Disabled (Default) – No Debounce Applied to any Input.
	1 Enabled – Reject A, B, or Index Pulses less than or equal to 2.4µs.
14	Counter Size:
	0 16-bit Counter (Default) ²
	1 32-bit Counter
15	Interrupt Enable
	0 Disable Interrupt Service (Default)
	1 Enable Interrupt Service

COUNTER CONTROL REGISTER

The Counter Control register bits 11 and 10 are used to control the operation of the counter output signal. With bits 11 and 10 set to "01", the output signal will be driven active while the counter equals the counter Constant A value. With bit 11 set to logic "1" the output signal will be driven active while the index condition remains true.

Encoder output signals can be noisy. It is recommended that the InA, InB, and InC input signals be debounced by setting bit-13 of the Counter Control register to logic "1". Noise transitions less than 2.4 μ s will be removed with debounce enabled.

Pulse Width Modulation

Pulse width modulated waveforms may be generated at the counter timer output. The pulse width modulated waveform is generated continuously. Pulse Width Modulation generation is selected by setting Counter Control Register bits 2 to 0 to logic "010".

Counter Constant A value controls the time until the pulse goes active. The duration of the pulse is set via the Counter Constant B register. Note that a high pulse will be generated if active high output is selected while a low pulse will be generated if active low output is selected.

The counter goes through a countdown sequence for each Counter Constant value. When the 0 count is detected, the output toggles to the opposite state. Then the second Counter Constant value is loaded into the counter, and countdown resumes, decrementing by one for each rising edge of the clock selected via Control Register bits 12, 11, and 10. For example, a counter constant value of 3 will provide a pulse duration of 3 clock cycles of the selected clock. Note, when the internal 20MHz clock is selected, a delay of one extra clock cycle will be added to the counter constant value.

InA can be used as a Gate-Off signal to stop and start the counter and thus the pulse-width modulated output. When InA is enabled via bits 5 and 4 of the control register for active low Gate-Off input, a logic low input will enable pulse-width modulation counting while a logic high will stop PWM counting. When InA is enabled for active high Gate-Off operation, a logic high will enable PWM counting while a logic low will stop PWM counting.

InB can be used to input an external clock for use in PWM. Bits 7 and 6 must be set to either logic "01" or "10". Additionally, the clock source bits 12, 11, and 10 must be set to logic "101" to enable external clock input. PWM can alternatively be clocked via an internal 1.25MHz, 2.5MHz, 5MHz, 10MHz, or 20MHz clock as selected via control register bits 12, 11, and 10.

InC can be used to externally trigger Pulse Width Modulation generation. Additionally, PWM can be triggered internally via the Counter Trigger Register at the base address + offset 1CH. An initial trigger, software or external, causes the pulse width modulated signal to be generated. After an initial trigger, do not issue additional triggers. Triggers issued while running will cause the Constant A and B values to load at the wrong time. In addition, changing the Control register setting while running can also cause the Constant A and B values to load at the wrong time.

If the Interrupt Enable bit of the Counter Control Register is set (bit 15) and bit-0 of the Interrupt register is set, an interrupt is generated when the

output pulse transitions from low to high and also for transitions from high to low. Thus, an interrupt is generated at each pulse transition.

COUNTER CONTROL REGISTER

PULSE WIDTH MODULATION

Bit(s)	FUNCTION
2,1,0	Specifies the Counter Mode:
	010 Pulse Width Modulation
3	Output Polarity (Output Pin ACTIVE Level):
	0 Active LOW (Default) ¹
	1 Active HIGH
5, 4	InA Polarity / Gate-Off Polarity
	00 Disabled (Default)
	01 Active LOW In A=0 Counter is Enabled In A=1 Counter is Disabled
	10 Active HIGH In A=0 Counter is Disabled In A=1 Counter is Enabled
	11 Disabled
7, 6	InB Polarity / External Clock Input
	00 Disabled (Default)
	01 External Clock Enabled
	10 External Clock Enabled
	11 Disabled
9,8	InC Polarity / External Trigger
	00 Disabled (Default)
	01 Active LOW External Trigger
	10 Active HIGH External Trigger
	11 Disabled
12,11,10	Clock Source
	000 Internal @ 1.25MHz (Default)
	001 Internal @ 2.5MHz
	010 Internal @ 5MHz
	011 Internal @ 10MHz
	100 Internal @ 20MHz
	101 External Clock (Up to 8MHz)
13	Input Debounce Enable
	0 Disabled (Default) – No Debounce Applied to any Input.
	1 Enabled – Reject Gate-Off or Trigger Pulses (noise) less than or equal to 2.4µs.
14	Counter Size:
	0 16-bit Counter (Default) ²
	1 32-bit Counter
15	Interrupt Enable
	0 Disable Interrupt Service (Default)
	1 Enable Interrupt Service

Table 3.8: Counter Control Register (Pulse Width Modulation)

1. The default state of the output pin is high (output has pullup installed). Bit 3 specifies the active output polarity when the output is driven.

2. When two 16-bit counters are selected to implement a 32-bit counter the control register corresponding to the first 16-bit counter is used for control of the 32 bit counter.

COUNTER CONTROL REGISTER**Watchdog Timer Operation**

The watchdog operation counts down from a programmed (Counter Constant A) value until it reaches 0. While counting, the counter output will be in its active state (the output polarity is programmable). Upon time-out, the counter output will return to its inactive state, and an optional interrupt may be generated. Watchdog operation is selected by setting Counter Control Register bits 2 to 0 to logic "011".

A timed-out watchdog timer will not re-cycle until it is reloaded and then followed with a new trigger. Failure to cause a reload would generate an automatic time-out upon re-triggering, since the counter register will contain the 0 it previously counted down to.

InA input can be used to reload the counter with the Constant A register value. InA reload input is enabled via Control register bits 5 and 4. The counter can also be reloaded via a software write to the Counter Constant A register. Writing to the Counter Constant A register will load the value directly into the counter even if watchdog counting is actively counting down.

InB can be used to input an external clock for watchdog timing. Bits 7 and 6 must be set to either logic "01" or "10". Additionally, the clock source bits 12, 11, and 10 must be set to logic "101" to enable external clock input. The timer can alternatively be clocked via an internal 1.25MHz, 2.5MHz, 5MHz, 10MHz, or 20MHz clock as selected via control register bits 12, 11, and 10.

InC can be used to either continue/stop watchdog counting or as an external trigger input. When control register bits 9 and 8 are set to logic "11", InC functions as a Continue/Stop signal. When the Continue/Stop signal is high the counter continues counting (when low the counter stops counting). Alternately, when control register bits 9 and 8 are set to logic "01" or "10", the InC input functions as an external trigger input. The watchdog timer may also be internally triggered (via the Trigger Control Register at the base address + offset 1CH).

When triggered, the counter/timer contents are decremented by one for each clock cycle, until it reaches 0, upon which a watchdog timer time-out occurs. For example, a counter constant value of 30 will provide a time-out delay of 30 clock cycles of the selected clock. However, due to the asynchronous relationship between the trigger and the selected clock, one clock cycle of error can be expected. The counter can be read from the Counter Readback register at any time during watchdog operation.

Upon time-out, the counter output pin returns to its inactive state. The board will also issue an interrupt upon detection of a count value equal to 0, if enabled via bit-15 of the Counter Control Register and bit-0 of the Interrupt register. This could be useful for alerting the host that a watchdog timer time-out has occurred and may need to be reinitialized. The interrupt will remain pending until the watchdog timer is reinitialized and the interrupt is released by setting the required bit of the Counter/Timer Interrupt Status/Clear register.

Bit(s)	FUNCTION
2,1,0	Specifies the Counter Mode:
	011 Watchdog Function
3	Output Polarity (Output Pin ACTIVE Level):
	0 Active LOW (Default) ¹
	1 Active HIGH
5, 4	InA Polarity / Counter Reload
	00 Disabled (Default)
	01 Active LOW In A=0 Counter Reinitialized In A=1 Inactive State
	10 Active HIGH In A=0 Inactive State In A=1 Counter Reinitialized
11 Disabled	
7, 6	InB Polarity / External Clock Input
	00 Disabled (Default)
	01 External Clock Enabled
	10 External Clock Enabled
11 Disabled	
9,8	InC Polarity / External Trigger
	00 Disabled (Default)
	01 Active LOW Trigger
	10 Active HIGH Trigger
11 Gate-Off (Continue when high/Stop when low)	
12,11,10	Clock Source
	000 Internal @ 1.25MHz (Default)
	001 Internal @ 2.5MHz
	010 Internal @ 5MHz
	011 Internal @ 10MHz
	100 Internal @ 20MHz
	101 External Clock (Up to 8MHz)
13	Input Debounce Enable
	0 Disabled (Default) – No Debounce Applied to any Input.
	1 Enabled – Reject Reinitialize or Trigger Pulses (noise) less than or equal to 2.4µs.
14	Counter Size:
	0 16-bit Counter (Default) ²
	1 32-bit Counter
15	Interrupt Enable
	0 Disable Interrupt Service (Default)
	1 Enable Interrupt Service

COUNTER CONTROL REGISTER

WATCHDOG TIMER OPERATION

Table 3.9: Counter Control Register (Watchdog Timer)

1. The default state of the output pin is high (output has pullup installed). Bit 3 specifies the active output polarity when the output is driven.

2. When two 16-bit counters are selected to implement a 32-bit counter the control register corresponding to the first 16-bit counter is used for control of the 32 bit counter.

COUNTER CONTROL REGISTER

Event Counting Operation

Positive or negative polarity events can be counted. Event Counting is selected by setting Counter Control Register bits 2 to 0 to logic "100" and setting bits 12 to 10 to logic "000".

Input pulses or events occurring at the input InB of the counter will increment the counter until it reaches the Counter Constant A value. Upon reaching the count limit, an output pulse of 1.6 μ s will be generated at the counter output pin, and an optional interrupt may be generated. Additionally, the internal event counter is cleared. The counter will continue counting, again from 0, until it reaches the Counter Constant A value. Once triggered, event counting will continue until disabled via Control register bits 2 to 0.

InA can be used as a Gate-Off signal to stop and start event counting. When InA is enabled via bits 5 and 4 of the control register for active low Gate-Off input, a logic low input will enable event counting while a logic high will stop event counting. When InA is enabled for active high Gate-Off operation, a logic high will enable event counting while a logic low will stop event counting.

InB is used as the event input signal. Active high or low input events can be selected via Control register bits 7 and 6. A minimum event pulse width (InB) of 100ns is required for correct pulse detection with input debounce disabled. Programmable clock selection is not available in event counter mode.

InC can be used to either control up/down counting or as an external trigger input. When control register bits 9 and 8 are set to logic "11", InC functions as an Up/Down signal. When the Up/Down signal is high the counter is in the count down mode (when low the counter counts up). The counter will not count down below a count of zero. Alternately, when control register bits 9 and 8 are set to logic "01" or "10", the InC input functions as an external trigger input. Event counting may also be internally triggered (via the Trigger Control Register at the base address + offset 34H).

The Counter Constant A Register holds the count-to value (constant). Reading the Counter Readback Register will return the current count (variable). **The Counter Constant A value must not be left as 0.** The counter upon trigger starts counting from 0 and since the counter would match the count-to value the counter resets and starts counting from zero again.

If the Interrupt Enable bit of the Counter Control Register is set (bit 15) and bit-0 of the Interrupt register is set, an interrupt is generated when the number of input pulse events is equal to the Counter Constant A register value. The internal counter is then cleared and will continue counting events until the counter constant A value is again reached and a new interrupt generated. An interrupt will remain pending until released by setting the required bit of the Counters Interrupt Status/Clear register at the base address + offset 04H. A pending interrupt can also be cleared, by setting Control register bit-15 to logic low.

Bit(s)	FUNCTION
2,1,0	Specifies the Counter Mode:
	100 Event Counting
3	Output Polarity (Output Pin ACTIVE Level):
	0 Active LOW (Default) ¹
	1 Active HIGH
5, 4	InA Polarity / Gate-Off
	00 Disabled (Default)
	01 Active LOW In A=0: Continue Counting In A=1: Stop Counting
	10 Active HIGH In A=0: Stop Counting In A=1: Continue Counting
	11 Disabled
7, 6	InB Polarity / Event Input
	00 Disabled (Default)
	01 Active LOW Events
	10 Active HIGH Events
	11 Disabled
9,8	InC Polarity / External Trigger
	00 Disabled (Default)
	01 Active LOW Trigger
	10 Active HIGH Trigger
	11 Up when logic low /Down when logic high Count Control
12,11,10	Specifies the Counter Mode:
	000 Event Counting
13	Input Debounce Enable
	0 Disabled (Default) – No Debounce Applied to any Input.
	1 Enabled – Reject Gate-Off, Event Input, Up/Down or Trigger Pulses (noise) less than or equal to 2.4µs.
14	Counter Size:
	0 16-bit Counter (Default) ²
	1 32-bit Counter
15	Interrupt Enable
	0 Disable Interrupt Service (Default)
	1 Enable Interrupt Service

COUNTER CONTROL REGISTER

EVENT COUNTING OPERATION

Table 3.10: Counter Control Register (Event Counting)

1. The default state of the output pin is high (output has pullup installed). Bit 3 specifies the active output polarity when the output is driven.

2. When two 16-bit counters are selected to implement a 32-bit counter the control register corresponding to the first 16-bit counter is used for control of the 32 bit counter.

COUNTER CONTROL REGISTER**Frequency Measurement Operation**

Frequency Measurement is selected by setting Counter Control Register bits 2 to 0 to logic "100" and setting bits 12 to 10 to logic "111". The counter counts how many InB edges (low to high or high to low) are received during the InA enable interval. The frequency is the number of counts divided by the duration of the InA enable signal.

InA is used as an enable signal to start frequency measurement. The InA signal must be a pulse of known width. When InA is configured (via bits 5 and 4 of the control register) as an active low enable input, a logic low input will enable frequency measurement while a logic high will stop frequency measurement. When InA is configured as an active high enable signal, a logic high will enable frequency measurement while a logic low will stop frequency measurement.

InB is used to input the signal whose frequency is to be measured. Input pulses occurring at input InB of the counter are counted while the enable signal present on InA is active. When the InA signal goes inactive, the counter output will generate a 1.6 μ s output pulse and an optional interrupt.

InC can be used as an external trigger input. When control register bits 9 and 8 are set to logic "01" or "10", the InC input functions as an external trigger input. Frequency measurement may also be internally triggered (via the Trigger Control Register at the base address + offset 1CH). An initial trigger, software or external, starts frequency measurement upon the active edge of the InA enable signal.

The Counter Constant A Register is not used for frequency measurement. Do not write to this register while the counter is actively counting since this will cause the counter to be loaded with the Constant A value.

Reading the Counter Readback Register will return the current count (variable). A minimum event pulse width (InB) of 100ns is required for correct pulse detection with input debounce disabled. With debounce enabled, a minimum event pulse width of 2.4 μ s is required for correct pulse detection. Programmable clock selection is not available for frequency measurement.

If the Interrupt Enable bit-15 of the Counter Control Register is set and bit-0 of the Interrupt register is set, an interrupt is generated when the input InA enable pulse goes inactive. An interrupt will remain pending until released by setting the required bit of the Interrupt Status/Clear register at the base address + offset 04H. A pending interrupt can also be cleared, by setting the Counter Control register bit-15 to logic low.

COUNTER CONTROL REGISTER

FREQUENCY MEASUREMENT OPERATION

Table 3.11: Counter Control Register (Frequency Measurement)

1. The default state of the output pin is high (output has pullup resistor installed). Bit 3 specifies the active output polarity when the output is driven.

2. When two 16-bit counters are selected to implement a 32-bit counter the control register corresponding to the first 16-bit counter is used for control of the 32 bit counter.

Bit(s)	FUNCTION
2,1,0	Specifies the Counter Mode:
	100 Frequency Measurement
3	Output Polarity (Output Pin ACTIVE Level):
	0 Active LOW (Default) ¹
	1 Active HIGH
5, 4	InA Polarity / Enable Pulse of Known Width
	00 Disabled (Default)
	01 Active LOW Pulse
	10 Active HIGH Pulse
	11 Disabled
7, 6	InB Polarity / Signal Measured/Counted
	00 Disabled (Default)
	01 Active LOW Pulse Counted
	10 Active HIGH Pulse Counted
	11 Disabled
9,8	InC Polarity / External Trigger
	00 Disabled (Default)
	01 Active LOW Trigger
	10 Active HIGH Trigger
	11 Disabled (Default)
12,11,10	Specifies the Counter Mode:
	111 Frequency Measurement
13	Input Debounce Enable
	0 Disabled (Default) – No Debounce Applied to any Input.
	1 Enabled – Reject Enable, Frequency Input, or Trigger Pulses less than or equal to 2.4µs.
14	Counter Size:
	0 16-bit Counter (Default) ²
	1 32-bit Counter
15	Interrupt Enable
	0 Disable Interrupt Service (Default)
	1 Enable Interrupt Service

COUNTER CONTROL REGISTER

Input Pulse Width Measurement

Setting bits 2 to 0 of the Counter Control Register to logic "101" configures the counter for pulse-width measurement. After pulse-width measurement is triggered, the first input pulse is measured.

InA is used to input the pulse to be measured. An active low or high pulse can be measured.

InB can be used to input an external clock for Pulse-Width Measurement. Bits 7 and 6 must be set to either logic "01" or "10". Additionally, the clock source bits 12, 11, and 10 must be set to logic "101" to enable external clock input. Pulse Width Measurement can alternatively be clocked via an internal 1.25MHz, 2.5MHz, 5MHz, 10MHz, or 20MHz clock as selected via control register bits 12, 11, and 10.

InC can be used to externally trigger Pulse Width Measurement. Additionally, Pulse Width Measurement can be triggered internally via the Counter Trigger Register at the base address + offset 1CH. An initial trigger, software or external, starts pulse width measurement at the beginning of the next active pulse.

For pulse-width measurement, the pulse-width being measured serves as an enable control for an up-counter whose value can be read from the Counter Readback Register. When triggered, the counter is reset and then increments by one for each clock pulse while the input signal level remains in the active state (high or low according to the programmed polarity of input InA). The resultant pulse-width is equivalent to the count value read from the Counter Readback Register, multiplied by the clock period. An output pulse will be generated at the counter output pin to signal the completion of a given measurement. Note that the measured pulse may be in error by ± 1 clock cycle.

Reading a counter value of 0xFFFF hex (for a 16-bit counter) or 0xFFFFFFFF hex (for a 32-bit counter) indicates that the pulse duration is longer than the current counter size and clock frequency can measure. Upon read of this overflow value you must select a slower clock frequency and re-measure.

An interrupt can be generated upon completion of a given pulse width measurement (the pulse has returned to the opposite polarity), if enabled via the interrupt enable bit of the Counter Control Register (bit 15) and bit-0 of the Interrupt register. The interrupt will remain pending until released by setting the required bit of the Interrupt Status/Clear register at the base address + offset 04H. A pending interrupt can also be cleared, by setting the Counter Control register bit-15 to logic low.

COUNTER CONTROL REGISTER

INPUT PULSE WIDTH MEASUREMENT

Bit(s)	FUNCTION	
2,1,0	Specifies the Counter Mode:	
	101	Pulse-Width Measurement
3	Output Polarity (Output Pin ACTIVE Level):	
	0	Active LOW (Default) ¹
	1	Active HIGH
5, 4	InA Polarity / Pulse Polarity to be Measured	
	00	Disabled (Default)
	01	Active LOW Pulse is Measured
	10	Active HIGH Pulse is Measured
	11	Disabled
7, 6	InB Polarity / External Clock Input	
	00	Disabled (Default)
	01	External Clock Enabled
	10	External Clock Enabled
	11	Disabled
9,8	InC Polarity / External Trigger	
	00	Disabled (Default)
	01	Active LOW Trigger
	10	Active HIGH Trigger
	11	Disabled
12,11,10	Clock Source	
	000	Internal @ 1.25MHz (Default)
	001	Internal @ 2.5MHz
	010	Internal @ 5MHz
	011	Internal @ 10MHz
	100	Internal @ 20MHz
	101	External Clock (Up to 8MHz)
13	Input Debounce Enable	
	0	Disabled (Default) – No Debounce Applied to any Input.
	1	Enabled – Reject Input Pulse Measured or Trigger Pulses (noise) less than or equal to 2.4µs. Using Debounce will add an error of up to 800ns when used for input pulse measurement.
14	Counter Size:	
	0	16-bit Counter (Default) ²
	1	32-bit Counter
15	Interrupt Enable	
	0	Disable Interrupt Service (Default)
	1	Enable Interrupt Service

Table 3.12: Counter Control Register (Input Pulse Width Measurement)

1. The default state of the output pin is high (output has pullup installed). Bit 3 specifies the active output polarity when the output is driven.

2. When two 16-bit counters are selected to implement a 32-bit counter the control register corresponding to the first 16-bit counter is used for control of the 32 bit counter.

COUNTER CONTROL REGISTER**Input Period Measurement**

The counter/timer may be used to measure the period of an input signal at the counter input InA. Setting bits 2 to 0 of the Counter Control Register to logic "110" configures the counter for period measurement. The first input cycle after period measurement is triggered will be measured.

InA is used to input the signal to be measured. Period measurement can be initiated on the active low or high portion of the waveform. The period of signal is the time the signal is low added to the time the signal is high, before it repeats.

InB can be used to input an external clock for period measurement. Bits 7 and 6 must be set to either logic "01" or "10". Additionally, the clock source bits 12, 11, and 10 must be set to logic "101" to enable external clock input. Period measurement can alternatively be clocked via an internal 1.25MHz, 2.5MHz, 5MHz, 10MHz, or 20MHz clock as selected via control register bits 12, 11, and 10.

InC can be used to externally trigger period measurement. Additionally, Period Measurement can be triggered internally via the Counter Trigger Register at the base address + offset 1CH. An initial trigger, software or external, starts period measurement at the beginning of the next active period.

The period being measured serves as an enable control for an up-counter whose value can be read from the Counter Readback Register. When triggered the counter is reset. Then, the active polarity of InA starts period measurement. The counter increments by one for each clock pulse during the input signal period (InA). The resultant period is equivalent to the count value read from the Counter Readback Register, multiplied by the clock period. A 1.6 μ s output pulse will be generated at the counter output pin to signal the completion of a given measurement. Note that the measured period may be in error by ± 1 clock cycle.

Reading a counter value of 0xFFFF hex (for a 16-bit counter) or 0xFFFFFFFF hex (for a 32-bit counter) indicates that the pulse duration is longer than the current counter size and clock frequency can measure. Upon read of this overflow value you must select a slower clock frequency and re-measure.

An interrupt can be generated upon completion of a given period measurement, if enabled via the interrupt enable bit of the Counter Control Register (bit 15) and bit-0 of the Interrupt register. The interrupt will be generated upon completion of the first complete waveform cycle after the counter is triggered. The interrupt will occur even if an external clock is selected but no clock signal is provided on InB. The count value will be zero in this case. The interrupt, once driven active, will remain pending until released by setting the required bit of the Interrupt Status/Clear register at the base address + offset 04H. A pending interrupt can also be cleared, by setting Counter Control register bit-15 to logic low.

COUNTER CONTROL REGISTER

INPUT PERIOD MEASUREMENT

Table 3.13: Counter Control Register (Input Period Measurement)

1. The default state of the output pin is high (output has pullup installed). Bit 3 specifies the active output polarity when the output is driven.

2. When two 16-bit counters are selected to implement a 32-bit counter the control register corresponding to the first 16-bit counter is used for control of the 32 bit counter.

Bit(s)	FUNCTION	
2,1,0	Specifies the Counter Mode:	
	110	Period Measurement
3	Output Polarity (Output Pin ACTIVE Level):	
	0	Active LOW (Default) ¹
	1	Active HIGH
5, 4	InA Polarity / Signal Measured	
	00	Disabled (Default)
	01	Active LOW portion of the signal starts period measurement.
	10	Active HIGH portion of the signal starts period measurement.
	11	Disabled
7, 6	InB Polarity / External Clock Input	
	00	Disabled (Default)
	01	External Clock Enabled
	10	External Clock Enabled
	11	Disabled
9,8	InC Polarity / External Trigger	
	00	Disabled (Default)
	01	Active LOW Trigger
	10	Active HIGH Trigger
	11	Disabled
12,11,10	Clock Source	
	000	Internal @ 1.25MHz (Default)
	001	Internal @ 2.5MHz
	010	Internal @ 5MHz
	011	Internal @ 10MHz
	100	Internal @ 20MHz
	101	External Clock (Up to 8MHz)
13	Input Debounce Enable	
	0	Disabled (Default) – No Debounce Applied to any Input.
	1	Enabled – Reject Source or Trigger Pulses (noise) less than or equal to 2.4µs. Using Debounce will add an error of up to 800ns when used for period measurement.
14	Counter Size:	
	0	16-bit Counter (Default) ²
	1	32-bit Counter
15	Interrupt Enable	
	0	Disable Interrupt Service (Default)
	1	Enable Interrupt Service

COUNTER CONTROL REGISTER**One-Shot Pulse Mode**

One-Shot pulse mode provides an output pulse that is asserted one time or repeated each time it is re-triggered. One-Shot generation is selected by setting Counter Control Register bits 2 to 0 to logic "111".

The Counter Constant A value controls the time until the pulse goes active. The duration of the pulse high or low is set via the Counter Constant B value. Note that the Constant B value defines the logic high pulse width, if active high output is selected, and a low pulse if active low output is selected.

The counter goes through a full countdown sequence for each Counter Constant value. When the 0 count is detected, on the next rising-edge of the clock, the output toggles to the opposite state, and the Counter Constant B value is loaded into the counter and countdown resumes, decrementing by one each clock cycle. For example, a counter constant value of 7 will provide a pulse duration of 7 clock cycles of the selected clock, then 50ns will be added for the count detection of 0.

InA can be used as a Gate-Off signal to stop and start the counter and, thus output. When InA is enabled via bits 5 and 4 of the control register for active low Gate-Off input, a logic low input will enable the one-shot counter while a logic high will stop the one-shot counter. When InA is enabled for active high Gate-Off operation, a logic high will enable the one-shot counter while a logic low will stop the one-shot counter.

InB can be used to input an external clock for use in one-shot. Bits 7 and 6 must be set to either logic "01" or "10". Additionally, the clock source bits 12, 11, and 10 must be set to logic "101" to enable external clock input.

InC can be used to externally trigger One-Shot pulse mode. Additionally, a one-shot pulse can be triggered internally via the Counter Trigger Register at the base address + offset 1CH. An initial trigger, software or external, causes the one-shot signal to be generated with no additional triggers required. Additional triggers must not be input until the one shot pulse has completed count down of the Constant B value.

If the Interrupt Enable bit-15 of the Counter Control Register is set, and bit-0 of the Interrupt register is set, an interrupt is generated when the pulse transitions from low to high and also when the pulse transitions from high to low. The interrupt will remain pending until released by setting the required bit of the Interrupt Status/Clear register at the base address + offset 04H. A pending interrupt can also be cleared, by setting the Counter Control register bit-15 to logic low.

COUNTER CONTROL REGISTER

ONE-SHOT PULSE MODE

Table 3.14: Counter Control Register (One-Shot Pulse)

1. The default state of the output pin is high (output has pullup installed). Bit 3 specifies the active output polarity when the output is driven.

2. When two 16-bit counters are selected to implement a 32-bit counter the control register corresponding to the first 16-bit counter is used for control of the 32 bit counter.

Bit(s)	FUNCTION	
2,1,0	Specifies the Counter Mode:	
	111	One-Shot Generation
3	Output Polarity (Output Pin ACTIVE Level):	
	0	Active LOW (Default) ¹
	1	Active HIGH
5, 4	InA Polarity / Gate-Off Polarity	
	00	Disabled (Default)
	01	Active LOW In A=0 Counter Enabled In A=1 Counter Disabled
		Active HIGH In A=0 Counter Disabled In A=1 Counter Enabled
	11	Disabled
7, 6	InB Polarity / External Clock Input	
	00	Disabled (Default)
	01	External Clock Enabled
	10	External Clock Enabled
	11	Disabled
9,8	InC Polarity / External Trigger	
	00	Disabled (Default)
	01	Active LOW Trigger
	10	Active HIGH Trigger
	11	Disabled
12,11,10	Clock Source	
	000	Internal @ 1.25MHz (Default)
	001	Internal @ 2.5MHz
	010	Internal @ 5MHz
	011	Internal @ 10MHz
	100	Internal @ 20MHz
	101	External Clock (Up to 8MHz)
13	Input Debounce Enable	
	0	Disabled (Default) – No Debounce Applied to any Input.
	1	Enabled – Reject Gate-Off or Trigger Pulses (noise) less than or equal to 2.4µs.
14	Counter Size:	
	0	16-bit Counter (Default) ²
	1	32-bit Counter
15	Interrupt Enable	
	0	Disable Interrupt Service (Default)
	1	Enable Interrupt Service

PROGRAMMING EXAMPLES

The following section provides sample applications for each of the counter modes of operation. This includes I/O pin assignments, register settings, required calculations, and waveform diagrams.

Quadrature Position Measurement Example

The objective for this example is to employ Quadrature Position Measurement using 32-bit RS422 Counter 1. Suppose that an encoder, connected to the shaft of a motor, provides three signals. Two of the signals (A and B) are out of phase by 90° and provide directional information. For this example, Channel A will always lead B. The third signal C is an Index pulse that is active every four revolutions (A pulses). Assume that X2 encoding is used and on the index pulse, when Channel A and B are equal to one, an active high output and interrupt are generated, and the counter is reloaded to zero. Additionally, debounce is enabled.

1. Connect the inputs/output to the following pins (unpowered):

Table 3.15: Quadrature Pin Assignments for Counter 1

Pin #	Connection	Pin #	Connection	Description
1	In1_A(+)	2	In1_A(-)	Channel A
36	In1_B(+)	37	In1_B(-)	Channel B
14	In1_C(+)	15	In1_C(-)	Index
48	Out1(+)	49	Out1(-)	Output

2. Write the following information, E9E9H, to Counter 1 Control Register located at base address plus an offset of 20H.

Table 3.16: Quadrature Counter Control Register 1 Settings

Bits	Logic	Operation
2,1,0	001	Sets the counter to Quadrature Position
3	1	Sets the output to active high.
5,4	10	Sets encoding to X2 and enables Channel A (InA).
6	1	Enables Channel B (InB).
9,8,7	011	Sets the Index condition to occur when A=1 and B=1.
11,10	10	Provides for interrupt and reload to occur on index.
12	0	Not used.
13	1	Enables input debounce on InA, InB, and InC.
14	1	Select a 32-bit counter size for use.
15	1	Enables interrupts. ¹

1. Make sure that bit 0 at base address plus an offset 0H is set to enable interrupts.

3. Write the 32-bit value 0H to Counter 1 Constant B Register located at base address plus an offset 80H for the counter reload value.

The Constant B Register contains the reload value of the counter. Therefore, in this example, when an index pulse occurs and Channel A and B are equal to one, the counter loads zero. This value relies on the specific application.

While Counter Constant A is not used in this example, it has other applications in Quadrature Position Measurement. Refer to the description of Quadrature mode for further information.

4. The following is a waveform diagram of this example. Since Quadrature mode does not accept external triggers, assume that a software trigger has already occurred.

PROGRAMMING EXAMPLES

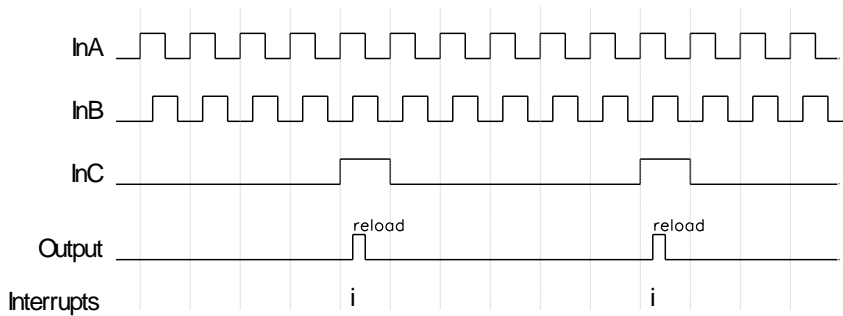

Figure 3.2: Quadrature waveform

In the figure, each “i” represents an interrupt

When the index condition is true the counter will reload the value in Counter Constant B register, and an interrupt is generated. The output remains active for as long as the Index condition holds true. For further information on encoder counting, index pulse conditions, interrupts, and outputs, see the Quadrature Position Measurement description.

Pulse Width Modulation Example

The objective for this example is to create a pulse width modulated output with an active high pulse of 2µs and a low pulse of 6µs using 32-bit RS422 Counter 2. The counter has an external active high gate-off, trigger, and clock signals. The output is active high. Assume the external clock has a frequency of 500KHz. The Gate-Off signal will become active after 2 PWM cycles. Additionally, debounce and interrupts are enabled.

1. Connect the inputs/output to the following pins (unpowered):

Pin #	Connection	Pin #	Connection	Description
3	In2_A(+)	4	In2_A(-)	Gate-Off
38	In2_B(+)	39	In2_B(-)	Ext. Clock
16	In2_C(+)	17	In2_C(-)	Ext. Trigger
50	Out2(+)	51	Out2(-)	Output

Table 3.17: PWM Pin Assignments for Counter 2

2. Write the following information, F66AH, to Counter 2 Control Register located at base address plus an offset of 28H.

Bits	Logic	Operation
2,1,0	010	Sets the counter to Pulse Width Modulation mode.
3	1	Sets the output to active high.
5,4	10	Enable the Gate-Off input (InA) to active high.
7,6	01	Enables the external clock input (InB).
9,8	10	Enables the external Trigger Input (InC) to active high.
12,11,10	101	Sets the clock to an external source.
13	1	Enables input debounce on InA and InC.
14	1	Select a 32-bit counter size for use.
15	1	Enables interrupts. ¹

Table 3.18: PWM Counter Control Register 2 Settings

1. Make sure that bit 0 at base address plus an offset 0H is set to enable interrupts.

3. Write the 32-bit value 3H to Counter 2 Constant A Register located at base address plus an offset 6CH for the non-active portion of the pulse, and

PROGRAMMING EXAMPLES

1H to Counter 2 Constant B Register located at base address plus an offset 84H for the active portion of the pulse.

In order to determine the necessary Counter Constant values first calculate the period of the selected clock (internal or external). The period is calculated by taking the inverse of the clock frequency. In this case, $1/500\text{KHz}$ is equal to $2\mu\text{s}$. Then take the total time for the low portion of the pulse and divide it by the clock period. For this example, $6\mu\text{s}/2\mu\text{s}$ is equal to 3. Convert this value to Hex and the result is the total count that is placed in the appropriate Counter Constant Register. Since it has been stipulated that the pulse is active high, 3H is written to Counter 2 Constant A Register, which contains the value for the non-active (low) portion of the pulse. The same procedure is used to calculate the Constant B value. Take the total period of the high portion of the pulse and divide it by the period of the clock. Here $2\mu\text{s}/2\mu\text{s}$ is equal to 1. Converting to hex, 1H is written to Counter 2 Constant B Register since it contains the active (high) portion of the pulse.

4. The following is a waveform diagram of this example.

Figure 3.3: PWM waveform

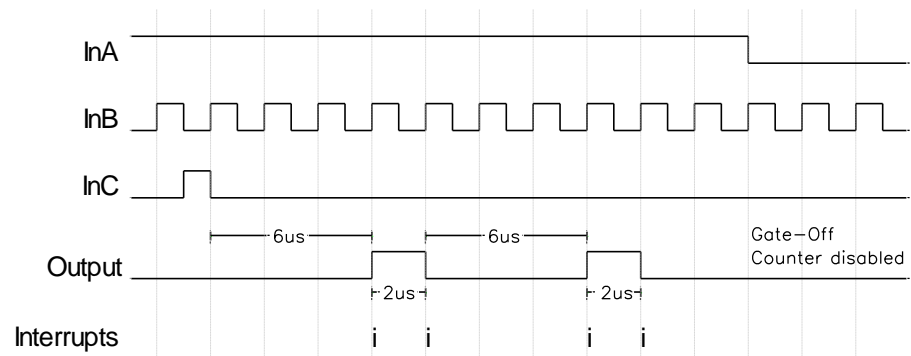

In the figure, each "i" represents an interrupt

Note that the InA and InC inputs run off the internal 20MHz clock. Those signals may not be synchronous with the selected clock. For further information, see the Pulse Width Modulation Operation description.

Watchdog Timer Operation Example

The objective for this example is to create a Watchdog Timer with a countdown duration of $10\mu\text{s}$ using 32-bit RS422 Counter 3 with an external active high counter reload, clock, and active low trigger signals. The output is active high. Assume the external clock has a frequency of 500KHz. The counter reload and trigger signals are periodic. Additionally, debounce and interrupts are enabled.

PROGRAMMING EXAMPLES

1. Connect the inputs/output to the following pins (unpowered):

Pin #	Connection	Pin #	Connection	Description
5	In3_A(+)	6	In3_A(-)	Reload
40	In3_B(+)	41	In3_B(-)	Ext. Clock
18	In3_C(+)	19	In3_C(-)	Ext. Trigger
52	Out3(+)	53	Out3(-)	Output

Table 3.19: Watchdog Pin Assignments for Counter 3

2. Write the following information, F56BH, to Counter 3 Control Register located at base address plus an offset of 30H.

Bits	Logic	Operation
2,1,0	011	Sets the counter to Watchdog mode.
3	1	Sets the output to active high.
5,4	10	Enable the Counter Reload input (InA) to active high.
7,6	01	Enables the external clock input (InB).
9,8	01	Enables the external Trigger Input (InC) to active low.
12,11,10	101	Sets the clock to an external source.
13	1	Enables input debounce on InA and InC.
14	1	Select a 32-bit counter size for use.
15	1	Enables interrupts. ¹

Table 3.20: Watchdog Counter Control Register 3 Settings

1. Make sure that bit 0 at base address plus an offset 0H is set to enable interrupts.

3. Write the 32-bit value 5H to Counter 3 Constant A Register located at the base address plus an offset of 70H.

In order to determine the correct Constant A Register value, first calculate the period of the selected clock. The period is calculated by taking the inverse of the clock frequency. In this case, 1/500KHz is equal to 2µs. Then take the total duration of the watchdog timer and divide it by the clock period. For this example, 10µs/2µs is equal to five. Converted to Hex, this is the number to write to the Counter 3 Constant A Register.

Counter Constant B Register is not used in Watchdog mode.

4. The following is a waveform diagram of this example.

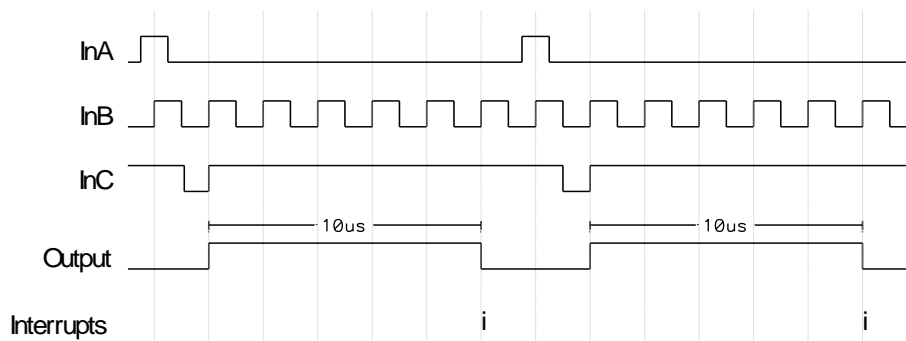

Figure 3.4: Watchdog waveform

In the figure each "i" represents an interrupt

In Watchdog mode, the counter must be loaded (InA) and then triggered (InC) for each cycle. While this can be done internally or externally, failure to follow this procedure will cause unpredictable results.

PROGRAMMING EXAMPLES

Note that the InA and InC inputs run off the internal 20MHz clock. Those signals may not be synchronous with the selected clock. For further information, see the Watchdog Timer Operation description.

Event Counting Operation Example

The objective for this example is to create an Event Counter that will count the number of active high events on InB using RS422 32-bit Counter 4. The output is active low. Additionally, the counter has an active low Gate-Off and an active low External Trigger. After every five events, the event counter interrupts.

1. Connect the inputs/output to the following pins (unpowered):

Table 3.21: Event Counting Pin Assignments for Counter 4

Pin #	Connection	Pin #	Connection	Description
7	In4_A(+)	8	In4_A(-)	Gate-Off
42	In4_B(+)	43	In4_B(-)	Event Input
20	In4_C(+)	21	In4_C(-)	Ext. Trigger
54	Out4(+)	55	Out4(-)	Output

2. Write the following information, C194H, to Counter 4 Control Register located at base address plus an offset of 38H.

Table 3.22: Event Counter Control Register 4 Settings

Bits	Logic	Operation
2,1,0	100	Sets the counter to Event Counting mode.
3	0	Sets the output to active low.
5,4	01	Enable the Gate-Off input (InA) to active low.
7,6	10	Enables the Event input (InB) to active high.
9,8	01	Enables the external Trigger Input (InC) to active low.
12,11,10	000	Sets the counter to Event Counting mode.
13	0	Disables input debounce on InA, InB, and InC.
14	1	Select a 32-bit counter size for use.
15	1	Enables interrupts. ¹

1. Make sure that bit 0 at base address plus an offset 0H is set to enable interrupts.

3. Write the 32-bit value 5H to Counter 4 Constant A Register located at the base address plus an offset of 74H.

Counter Constant B Register is not used in Event Counting mode.

In Event Counting, when the Constant A Register is equal to the value in the Read Back Register, in this case located at base address plus an offset of 5CH, there is an output pulse and an interrupt. Furthermore, when this condition occurs, the counter resets to zero and starts incrementing again. For this example, an interrupt and output pulse will occur every five events. Therefore 5H is written to the Counter 4 Constant A Register. Note that all values are stored and read in Hex.

4. The following is a waveform diagram of this example.

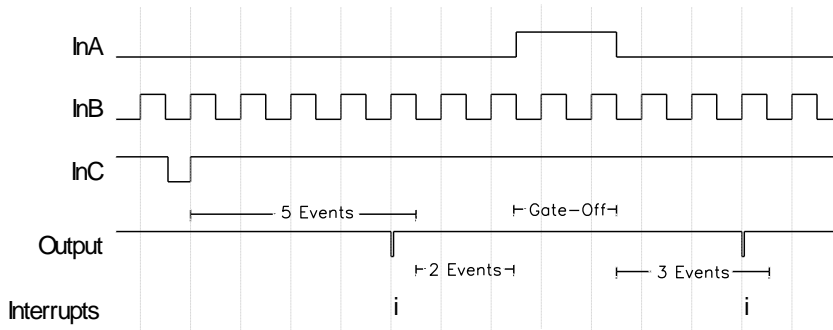

PROGRAMMING EXAMPLES

Figure 3.5 Event Counting waveform

In the figure, each “i” represents an interrupt

The Gate-Off signal is used in this example to pause the counter. While the Gate-Off signal is non-active (logic high), the counter and output will remain constant. Additionally, the output pulse is active for 1.6µs upon the detection of the final event. For further information, see the Event Counting Operation description.

Frequency Measurement Operation Example

The objective for this example is to use the Frequency Measurement Operation using RS422 32-bit Counter 4. The enable signal and the signal measured are active high. Additionally, the counter has an active low External Trigger. The output of the counter is active low and interrupts and debounce are enabled. Assume the enable pulse has a duration of 50µs.

1. Connect the inputs/output to the following pins (unpowered):

Pin #	Connection	Pin #	Connection	Description
7	In4_A(+)	8	In4_A(-)	Enable Input
42	In4_B(+)	43	In4_B(-)	Signal Input
20	In4_C(+)	21	In4_C(-)	Ext. Trigger
54	Out4(+)	55	Out4(-)	Output

Table 3.23: Frequency Measurement Pin Assignments for Counter 4

2. Write the following information, FDA4H, to Counter 4 Control Register located at base address plus an offset of 38H.

Bits	Logic	Operation
2,1,0	100	Sets the counter to Frequency Measurement.
3	0	Sets the output to active low.
5,4	10	Sets the Enable Pulse input (InA) to active high.
7,6	10	Enables the Signal input (InB) to active high.
9,8	01	Enables the external Trigger Input (InC) to active low.
12,11,10	111	Sets the counter to Frequency Measurement mode.
13	1	Enables input debounce on InA, InB, and InC.
14	1	Select a 32-bit counter size for use.
15	1	Enables interrupts. ¹

Table 3.24: Frequency Measurement Control Register 4 Settings

1. Make sure that bit 0 at base address plus an offset 0H is set to enable interrupts.

PROGRAMMING EXAMPLES

Figure 3.6: Frequency Measurement waveform

- Do *not* write to either of the Counter 4 Constant Registers. They are not required for frequency measurement and writing to them can cause errors.
- The following is a waveform diagram of this example.

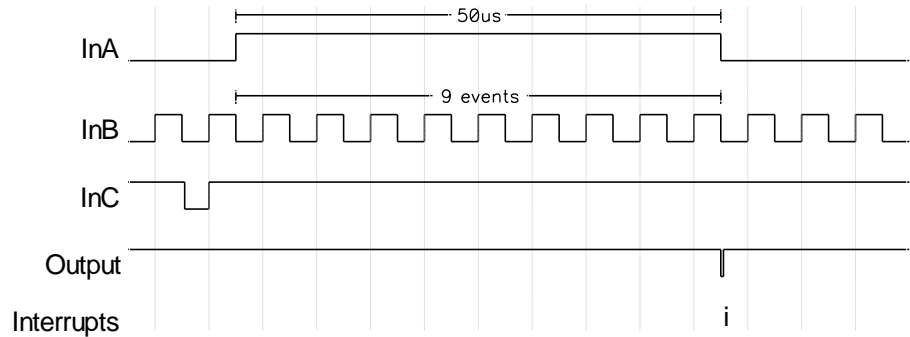

In the figure, each "i" represents an interrupt

The frequency of the signal is calculated by dividing the value in the Counter 4 Read Back Register, located at base address plus an offset of 5CH, by the duration of the InA enable signal. Note that the value in the Read Back Register is stored in Hex and requires conversion to decimal for calculations. In this case the pulse length is 50µs. The value in the Read Back Register is 9, since there were nine high pulses during the enable signal. Therefore, the frequency is 9/50µs, which is equal to 180KHz.

Note that the counter must be re-triggered before the next frequency measurement can take place. Additionally, the output pulse is active for 1.6µs. Since debounce was enabled the output pulse will occur 2.4µs after the completion of the enable signal. For further information, see the Frequency Measurement Operation description.

Input Pulse-Width Measurement Example

The objective for this example is to use the Pulse-Width Measurement Operation using TTL 32-bit Counter 5. The pulse to be measured is active low. Additionally, the counter has an external clock and an active low External Trigger. The output of the counter is active high and interrupts are enabled. Assume the external clock has a frequency of 100KHz.

Since Counter 5 is a 32-bit TTL counter, Counter 6 cannot be used.

Table 3.25: Pulse-Width Measurement Pin Assignments for Counter 5

- Connect the inputs/output to the following pins (unpowered):

Pin #	Connection	Description
9	In5_A(+)	Pulse Input
44	In5_B(+)	Ext. Clock
22	In5_C(+)	Ext. Trigger
56	Out5(+)	Output

Note: Make sure all inputs and outputs are properly grounded.

2. Write the following information, D59DH, to Counter 5 Control Register located at base address plus an offset of 40H.

PROGRAMMING EXAMPLES

Bits	Logic	Operation
2,1,0	101	Sets the counter to Pulse-Width Measurement.
3	1	Sets the output to active high.
5,4	01	Sets the Pulse input (InA) to active low.
7,6	10	Enables the external clock input (InB).
9,8	01	Enables the external Trigger Input (InC) to active low.
12,11,10	101	Sets the clock to an external source.
13	0	Disables input debounce on InA and InC.
14	1	Select a 32-bit counter size for use.
15	1	Enables interrupts. ¹

Table 3.26: Pulse-Width Measurement Control Register 5 Settings

1. Make sure that bit 0 at base address plus an offset 0H is set to enable interrupts.

3. Do *not* write to either of the Counter 5 Constant Registers. They are not required for pulse-width measurement and writing to them can cause errors.

4. The following is a waveform diagram of this example.

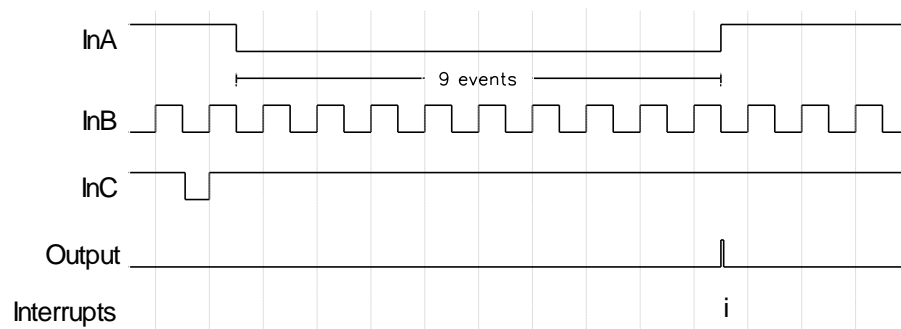

Figure 3.7: Pulse-Width Measurement waveform

In the figure, each "i" represents an interrupt

The length of the low portion of the InA pulse is calculated by multiplying the number in the Counter 5 Read Back Register, located at base address plus an offset of 60H, by the period of the selected clock. Note that the value in the Read Back Register is stored in Hex and requires conversion to decimal for calculations. In this case the value in the Read Back Register is 9, since there were nine high pulses during the active InA signal. The period of the clock is calculated by taking the inverse of the frequency of the clock. For this example, the frequency was 100KHz. Therefore, the clock period is 1/100KHz, which is equal to 10µs. The clock period multiplied by the Read Back Register 10µs x 9, is equal to 90µs, the duration of the active low InA pulse. This value may be in error by ± 1 clock period.

Note that the InA and InC inputs run off the internal 20MHz clock. Those signals may not be synchronous with the selected clock. The output pulse is active for 1.6µs. If debounce was enabled the output pulse will occur 2.4µs after the completion of the input pulse. Additionally, the counter must be re-triggered before any further measurements take place. For more information, see the Pulse-Width Measurement description.

PROGRAMMING EXAMPLES

Since Counter 7 is a 32-bit TTL counter, Counter 8 cannot be used.

Table 3.27: Input Period Measurement Pin Assignments for Counter 7

Input Period Measurement Example

The objective for this example is to use the Input Period Measurement operation using TTL 32-bit Counter 7. The high-to-low transition of the input signal will begin measurement. Additionally, the counter has an external clock and an active high External Trigger. The output of the counter is active high and interrupts are enabled. Assume the external clock has a frequency of 250KHz.

1. Connect the inputs/output to the following pins (unpowered):

Pin #	Connection	Description
11	In7_A(+)	Pulse Input
46	In7_B(+)	Ext. Clock
24	In7_C(+)	Ext. Trigger
58	Out7(+)	Output

Note: Make sure all inputs and outputs are properly grounded.

2. Write the following information, D65EH, to Counter 7 Control Register located at base address plus an offset of 48H.

Table 3.28: Input Period Measurement Control Register 7 Settings

Bits	Logic	Operation
2,1,0	110	Sets the counter to Input Period Measurement.
3	1	Sets the output to active high.
5,4	01	Sets the Pulse input (InA) to active low.
7,6	01	Enables the external clock input (InB).
9,8	10	Enables the external Trigger Input (InC) to active high.
12,11,10	101	Sets the clock to an external source.
13	0	Disables input debounce on InA and InC.
14	1	Select a 32-bit counter size, for use.
15	1	Enables interrupts. ¹

1. Make sure that bit 0 at base address plus an offset 0H is set to enable interrupts.

3. Do *not* write to either of the Counter 7 Constant Registers. They are not required for input period measurement and writing to them can cause errors.

4. The following is a waveform diagram of this example.

Figure 3.8: Input Period Measurement waveform

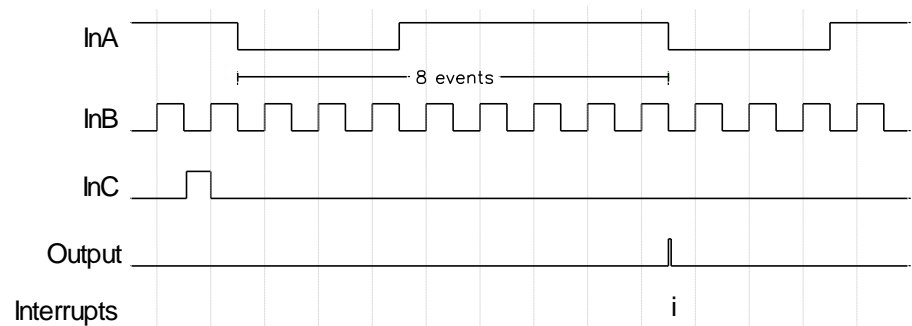

In the figure, each "i" represents an interrupt

The period of one cycle of the InA waveform is calculated by multiplying the number in the Counter 7 Read Back Register, located at the base address plus an offset of 64H, by the period of the selected clock. Note that the value in the Read Back Register is stored in Hex and requires

conversion to decimal for calculations. In this case the value in the Counter 7 Read Back Register is 8, since there were eight high pulses during one InA period. The period of the clock is calculated by taking the inverse of the frequency of the clock. For this example, the frequency was 250KHz. Therefore, the clock period is 1/250KHz, which is equal to 4µs. The clock period multiplied by the Read Back Register, 4µs x 8, is equal to 32µs (the period of the InA waveform). This value may be in error by ± 1 clock period.

Note that the InA and InC inputs run off the internal 20MHz clock. Those signals may not be synchronous with the selected clock. The output pulse is active for 1.6µs. If debounce was enabled, the output pulse will occur 2.4µs after the completion of the input pulse. Additionally, the counter must be re-triggered before any further measurements take place. For more information, see the Input Period Measurement description.

PROGRAMMING EXAMPLES

One-Shot Pulse Mode Example

The objective for this example is to use the One-Shot Pulse mode using TTL 32-bit Counter 7. The output pulse is active high with the low portion 20µs long and the high portion 5 µs long. Additionally, the counter has an external clock, an active high Gate-off signal, and an active high External Trigger. Interrupts are enabled. Assume the external clock has a frequency of 200KHz.

1. Connect the inputs/output to the following pins (unpowered):

Pin #	Connection	Description
11	In7_A(+)	Gate-Off
46	In7_B(+)	Ext. Clock
24	In7_C(+)	Ext. Trigger
58	Out7(+)	Output

2. Write the following information, D66FH, to Counter 7 Control Register located at base address plus an offset of 48H.

Bits	Logic	Operation
2,1,0	111	Sets the counter to One-Shot Pulse generation mode.
3	1	Sets the output to active high.
5,4	10	Sets the Gate-Off input (InA) to active high.
7,6	01	Enables the external clock input (InB).
9,8	10	Enables the external Trigger Input (InC) to active high.
12,11,10	101	Sets the clock to an external source.
13	0	Disables input debounce on InA and InC.
14	1	Select a 32-bit counter size for use.
15	1	Enables interrupts. ¹

3. Write the 32-bit value 4H to Counter 7 Constant A Register located at base address plus an offset 7CH for the non-active portion of the pulse, and 1H to Counter 7 Constant B Register located at base address plus an offset 94H for the active portion of the pulse.

Since Counter 7 is a 32-bit TTL counter, Counter 8 cannot be used.

Table 3.29: One-Shot Pulse Pin Assignments for Counter 7

Note: Make sure all inputs and outputs are properly grounded.

Table 3.30: One-Shot Pulse Control Register 7 Settings

1. Make sure that bit 0 at base address plus an offset 0H is set to enable interrupts.

PROGRAMMING EXAMPLES

In order to determine the necessary Counter Constant values first calculate the period of the selected clock (internal or external). The period is calculated by taking the inverse of the clock frequency. In this case, $1/200\text{KHz}$ is equal to $5\mu\text{s}$. Then, take the total time for the low portion of the pulse and divide it by the clock period. For this example, $20\mu\text{s}/5\mu\text{s}$ is equal to 4. Convert this value to Hex and the result is the total count that is placed in the appropriate Counter Constant Register. Since it has been stipulated that the pulse is active high, 4H is written to the Counter 7 Constant A Register, which contains the value for the non-active (low) portion of the pulse. The same procedure is used to calculate the Constant B value. Take the total period of the high portion of the pulse and divide it by the period of the clock. For this example, $5\mu\text{s}/5\mu\text{s}$ is equal to 1. Converting to hex, 1H is written to Counter 7 Constant B Register since it contains the active (high) portion of the pulse.

4. The following is a waveform diagram of this example.

Figure 3.9: One-Shot Pulse waveform

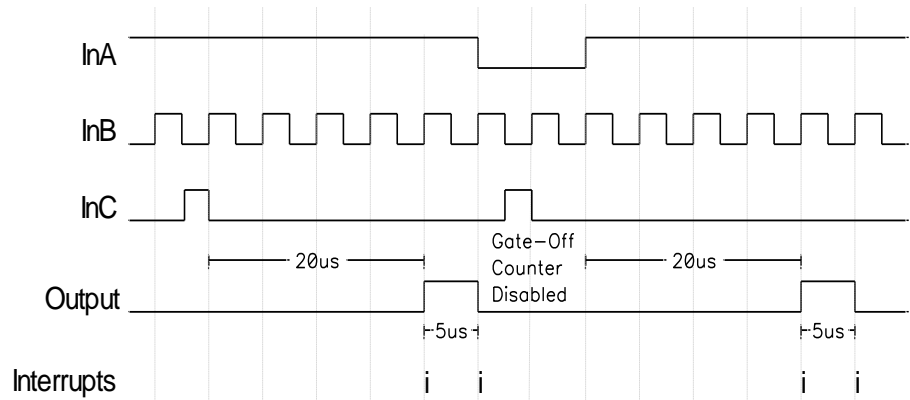

In the figure, each "i" represents an interrupt

The Gate-Off signal (InA) is used as a pause mechanism. The counter register and output remain constant while the Gate-Off signal is active. In this example, this occurs when InA is logic low.

Note that the InA and InC inputs run off the internal 20MHz clock. Those signals may not be synchronous with the selected clock. For further information, see the One-Shot Pulse Mode description.

Table 3.31: Counter Timer Modes Overview

Function Description	Pulse Width Modulation/ One-Shot	Watchdog	Event Counting	Frequency Measure	Pulse Measure	Period Measure	Quadrature Position Measure
InA Input	Gate-Off for start/stop control	Counter Reload	Gate-Off for start/stop control	Enable Frequency Measurement for Set Duration	Next complete pulse after trigger is measured.	Next complete period after trigger is measured.	Channel A
InB Input	External Clock	External Clock	Event Input	Signal Measured/ Counted	External Clock	External Clock	Channel B
InC Input	External Trigger	External Trigger or Gate-Off for start/stop control	External Trigger or Up/Down Count Control	External Trigger	External Trigger	External Trigger	Index
Internal Software Trig	Starts Waveform Generation	Starts Count Down	Start Event Counting	Start Frequency Measurement on next active edge of InA signal.	Next complete pulse after trigger is measured.	Next complete period after trigger is measured.	Starts Quadrature Measurement
Counter Timer Output	Output Waveform	Output is active from trigger until terminal count.	1.75µs pulse is output upon reaching the count limit	1.75µs pulse is output upon end of frequency measurement	1.75µs pulse is output upon end of pulse measurement	1.75µs pulse is output upon end of period measurement	Output pulse while index or programmed count limit remains true.
Constant A Reg	Count down from value loaded. Defines duration until active pulse	Counts down from value loaded. Must always load before trigger. Note that InA input can be used to reload.	Count Limit. Input events are counted up to the count limit.				An interrupt can be generated when the counter equals the Constant A value.
Constant B Reg	Count down from value loaded. Defines duration of active pulse						Constant B can be reloaded on occurrence of an Index signal.
Counter Read Back Reg		Gives the Count value at the time of the read.	Gives the Count value at the time read.	Gives count value reflecting measurement	Gives count value reflecting pulse measured	Gives count value reflecting period measured	Gives count value reflecting position measurement
Interrupt	On Edge Transitions	On Terminal Count of 0	Upon reach of count limit	Upon end of enable pulse	Upon end of pulse measurement	Upon end of period measurement	On Index or Constant A count limit.

4.0 THEORY OF OPERATION

This section contains information regarding the hardware of the board. A description of the basic functionality of the circuitry used on the board is also provided. Refer to the Block Diagram shown in Drawing 4501-953 as you review this material.

A Field Programmable Gate-Array (FPGA) installed on the board provides an interface to the carrier/CPU board per PCI Local Bus Specification 2.2. The interface to the carrier/CPU board allows complete control of all board functions.

PCI INTERFACE LOGIC

This is a target only board, with the PCI bus interface logic imbedded within the FPGA. This logic includes support for PCI commands, including: configuration read/write, and memory read/write. In addition, the PCI target interface performs parity error detection, uses a single 4K base address register, and implements target abort, retry, and disconnect. The logic also implements interrupt requests via interrupt line INTA#.

COUNTER TIMER CONTROL LOGIC

Differential RS422 input control signals In_A \pm , In_B \pm , and In_C \pm are available for the four fixed 32-bit counters of the board. TTL logic level input control signals InA, InB, and InC are available for the four 16-bit counters. See Table 2.1 for the list of these signals and their corresponding pin assignments.

Counter timer out signals OUT1 \pm to OUT4 \pm are differential RS422 signals output from the four fixed 32-bit counters. OUT5 to OUT8 are TTL logic levels output from the four 16-bit counters. See Table 2.1 for the output signals and their corresponding pin assignments.

DIGITAL INPUT/OUTPUT LOGIC

The digital field I/O interface to the board is provided through Field I/O Connector (refer to Table 2.1). *Field I/O points are NON-ISOLATED.* This means that the field return and logic common have a direct electrical connection to each other. As such, care must be taken to avoid ground loops. Ignoring this effect may cause operation errors, and with extreme abuse, possible circuit damage.

Digital input/output signals to the FPGA are buffered using buffered line drivers. Field inputs to these buffers include transient protection devices on each line and a 4.7K pullup resistor to +5V. Output operation is considered 'Fail-safe'. That is, the Digital Input/Output signals are always configured as input upon power-up reset or software reset. This is done for safety reasons to ensure reliable control under all conditions.

Digital channels of this model can be configured to generate interrupts for Change-Of-State (COS) and input level (polarity) match conditions on all channels (channels 0-15). The interrupt is released via a write to the corresponding bit of the Digital Interrupt Status register.

Surface-Mounted Technology (SMT) boards are generally difficult to repair. It is highly recommended that a non-functioning board be returned to Acromag for repair. The board can be easily damaged unless special SMT repair and service tools are used. Further, Acromag has automated test equipment that thoroughly checks the performance of each board. When a board is first produced and when any repair is made, it is tested, placed in a burn-in room at elevated temperature, and retested before shipment.

Please refer to Acromag's Service Policy Bulletin or contact Acromag for complete details on how to obtain parts and repair.

Before beginning repair, be sure that all of the procedures in Section 2, Preparation for Use, have been followed. Also, refer to the documentation of your carrier/CPU board to verify that it is correctly configured. Replacement of the board with one that is known to work correctly is a good technique to isolate a faulty board.

Acromag's Applications Engineers can provide further technical assistance if required. When needed, complete repair services are also available from Acromag.

If you continue to have problems, your next step should be to visit the Acromag worldwide web site at <http://www.acromag.com>. Our web site contains the most up-to-date product and software information.

Go to the "Support" tab to access:

- Application Notes
- Frequently Asked Questions (FAQ's)
- Product Knowledge Base
- Tutorials
- Software Updates/Drivers

An email question can also be submitted from within the Knowledge Base of directly from the "Contact Us" tab.

Acromag's application engineers can also be contacted directly for technical assistance via telephone or FAX through the numbers listed at the bottom of this page. If needed, complete repair services are also available.

5.0 SERVICE AND REPAIR

SERVICE AND REPAIR ASSISTANCE

PRELIMINARY SERVICE PROCEDURE

CAUTION: POWER MUST BE TURNED OFF BEFORE REMOVING OR INSERTING BOARDS

WHERE TO GET HELP

www.acromag.com

6.0 SPECIFICATIONS

PHYSICAL

Single PMC Board

Height	13.5 mm (0.531 in)
Stacking Height	10.0 mm (0.394 in)
Depth	149.0 mm (5.866 in)
Width	74.0 mm (2.913 in)
Board Thickness	1.59 mm (0.062 in)

Short PCI Board

Height	106.68 mm (4.2 in)
Depth	167.64 mm (6.6 in)
Board Thickness	1.59 mm (0.062 in)
Max Component Height	14.48 mm (0.57 in)
Card Spacing	20.32 mm (0.8 in)

3UCompactPCI Board

Height	100.0 mm (3.937 in)
Depth	160.0 mm (6.299 in)
Board Thickness	1.59 mm (0.062 in)
Max Component Height	13.97 mm (0.55 in)
Card Spacing	20.32 mm (0.8 in)

Connectors

- **PMC483:** PCI Local Bus Interface: Two 64-pin female receptacle header (AMP 120527-1 or equivalent). Universally keyed for 3.3V or 5V signaling.
- **AcPC483:** PCI Local Bus Interface: Type "A" right angle female connector, 110 contacts with upper shield. Universally keyed for 3.3V or 5V signaling.
- **APC483:** PCB card "finger" edge connector. Universally keyed for 3.3V or 5V signaling.
- **Front Field I/O:** 68-pin, SCSI-3, female receptacle header (AMP 787082-7 or equivalent) for all front I/O models
- **Rear Field I/O:** 64-pin female receptacle header (AMP 120527-1 or equivalent) for PMC rear I/O models only.

Table 6.1: Power Requirements

5V Maximum rise time of 100m seconds.

Power Requirements		PMC483, APC483, AcPC483
5V ($\pm 5\%$)	Typical	300mA
	Max.	420mA
+/-12V ($\pm 5\%$)	Not used	

ENVIRONMENTAL

Operating Temperature: 0 to +70°C. -40°C to +85°C (E Version)

Relative Humidity: 5-95% Non-Condensing.

Storage Temperature: -55°C to 125°C. (-55°C to 105°C for PMC Models)

Non-Isolated: Logic and field commons have a direct electrical connection.

FCC: Only the APC Models are compliant to standard FCC PART 15, Subpart.

FCC

NOTE: This equipment has been tested and found to comply with the limits for a Class B digital device, pursuant to part 15 of the FCC Rules. These limits are designed to provide reasonable protection against harmful interference in a residential installation. This equipment generates, uses, and can radiate radio frequency energy and, if not installed and used in accordance with the instruction manual, may cause harmful interference to radio communications. However, there is no guarantee that interference will not occur in a particular installation. If this installation does cause harmful interference to the radio or television reception, which can be determined by turning the equipment off and on, the user is encouraged to try to correct the interference by one or more of the following measures:

- Reorient or relocate the receiving antenna.
- Increase the separation between the equipment and receiver.
- Connect the equipment into an outlet on a circuit different from that to which the receiver is connected.
- Consult the dealer or experienced radio/TV technician for help.

Mean Time Between Failure: MTBF = 1,727,707 hours calculated for PMC483 (other models expected to be similar) @ 25°C, Using MIL-HDBK-217F, Notice 2.

Channel Configuration: 16 Bi-directional TTL Transceivers Direction controlled as 16 independent channels. Rear I/O models only provided 12 digital I/O channels.

Reset/Power Up Condition: All Digital Channels Default to Input.

Pull-up Resistors: 4.7KΩ pull-up resistor networks are installed in sockets. Two networks of 8 resistors each are utilized for the Digital I/O. R28 for Digital I/O (0 to 7) and R27 for Digital I/O (8 to 15).

- V_{OH}: 3.8V minimum
- V_{OL}: 0.55V maximum
- I_{OH}: -32.0mA
- I_{OL}: 32mA
- V_{IH}: 3.5V minimum
- V_{IL}: 1.5V maximum

Counter Functions: Quadrature Position Measurement, Pulse Width Modulation, Watchdog Timer, Event Counting, Frequency Measurement, Period Measurement, Pulse-Width Measurement, and One Shot/Repetitive

Four 32-Bit counters: - Four fixed 32-bit counters are available with RS422 differential I/O.

SPECIFICATIONS

Reliability Prediction

Digital Input/Output

Digital I/O DC Electrical Characteristics

16 or 32-Bit Counters

Configuration

SPECIFICATION

Four 16-Bit counters: - A pair of 16-bit counters can be configured into a 32-bit counter. The 16-bit counters utilize TTL I/O.

TTL Counter Input	InA, InB, and InC input signals of counters 5 to 8 are TTL. These TTL input ports are used to control Start/Stop, Reload, Event Input, External Clock, Trigger, and Up/Down operations.
TTL Input Electrical Characteristics	<ul style="list-style-type: none">• V_{IH}: 2.0V minimum• V_{IL}: 0.8V maximum <p>Pull-up Resistors: 4.7KΩ pull-up resistor networks are installed in sockets. Networks of 8 resistors each are utilized for the counter input.</p> <ul style="list-style-type: none">• R23: InA 5 to 8 and InC 5 to 8• R25: InB 5 to 8
RS422 Counter Input	InA\pm, InB\pm, and InC\pm input signals of counters 1 to 4 are differential RS422. These differential input ports are used to control Start/Stop, Reload, Event Input, External Clock, Trigger, and Up/Down operations.
RS422 Input Electrical Characteristics	<p>Fail-Safe: When differential inputs are left floating, receiver output is logic high.</p> <ul style="list-style-type: none">• -0.2 Min to 0.2 Max: Differential Input Threshold Voltage with $-7V \leq V_{CM} \leq 12V$• 60mV Typical: Input Hysteresis• 12KΩ Minimum Input Resistance <p>Termination Resistors: 120Ω termination resistor networks are installed in sockets. Networks of 4 resistors each are utilized for the counter differential inputs.</p> <ul style="list-style-type: none">• R50: In_A\pm, 1 to 4• R53: In_B\pm, 1 to 4• R52: In_C\pm, 1 to 4
RS422 Counter Output	Counters 1 to 4 each have RS422 differential Output. The RS422 output ports 1 to 4 are used for waveform output, watchdog active indicator, or 1.6 μ s pulse upon counter function completion. Counter output is programmable as active high or low.
RS422 Output Electrical Characteristics	<ul style="list-style-type: none">• 2 V Minimum: Differential Driver Output Voltage with 50Ω load.• 3 V Maximum: Common Mode Output Voltage.
TTL Counter Output	Counters 5 to 8 each have one Output Port. The TTL output ports 5 to 8 are used for waveform output, watchdog active indicator, or 1.6 μ s pulse upon counter function completion. Counter output is programmable as active high or low.
TTL Output Electrical Characteristics	<ul style="list-style-type: none">• V_{OH}: 2.4V minimum• V_{OL}: 0.55V maximum

SPECIFICATIONS

- I_{OH}: -15.0mA
- I_{OL}: 64mA

Pull-up Resistors: 4.7K Ω pull-up resistor is installed for each Counter Output.

Debounce Interval 2.4 μ s Enabled/Disable via Counter Control Register

Selectable Counter Clock Frequencies: 20MHz, 10MHz, 5MHz, 2.5MHz, 1.25MHz or External up to 8MHz

Minimum I/P Event: 100ns

Minimum Pulse Measurement: 100ns

Minimum Period Measurement: 200ns

Minimum Gate/Trigger Pulse: 100ns

Clock Frequency: 20MHz

Frequency Stability: 25ppm. This is ± 1.25 ps for each clock cycle. For example, if you were to measure a pulse with a half second duration,

Board Crystal Oscillator**PCI Local Bus Interface**

using the counter measurement function, your accuracy would be ± 12.5 μ s.

PMC483 Compatibility: Conforms to PCI Bus Specification, Revision 2.2 and PMC Specification, P1386.1

APC483 Compatibility: Conforms to PCI Bus Specification, Revision 2.2

AcPC483 Compatibility: Conforms to PCI Bus Specification, Revision 2.2 and CompactPCI Specification PICMG 2.0 R2.1

PCI Target: Implemented by Altera FPGA

4K Memory Space Required: One Base Address Register

PCI commands Supported: Configuration Read/Write memory Read/Write, 32, 16, and 8-bit data transfer types supported.

Signaling: 5V Compliant, 3.3V Tolerant

INTA#: Interrupt A is used to request an interrupt. Source of interrupt can be from the Digital I/O, or Counter/Timer Functions.

Access Times: 8 PCI Clock Cycles for all register accesses.

APPENDIX

CABLE: MODEL 5028-432 (SCSI-3 to Round, Shielded)

Type: Round shielded cable, 34 twisted pairs (SCSI-3 male connector at both ends). The cable length is 2 meters (6.56 feet). This shielded cable is recommended for all I/O applications (both digital I/O and precision analog I/O).

Application: Used to connect Model 5025-288 termination panel to the Board.

Length: Standard length is 2 meters (6.56 feet). Consult factory for other lengths. It is recommended that this length be kept to a minimum to reduce noise and power loss.

Cable: 68 conductors, 28 AWG on 0.050 inch centers (permits mass termination for IDC connectors), foil/braided shield inside a PVC jacket.

Connectors: SCSI-3, 68-pin male connector with backshell.

Keying: The SCSI-3 connector has a "D Shell".

Schematic and Physical Attributes: See Drawing 4501-919.

Electrical Specifications: 30 VAC per UL and CSA (SCSI-3 connector spec.'s). 1 Amp maximum at 50% energized (SCSI-3 connector spec.'s).

Operating Temperature: -30°C to +80°C.

Storage Temperature: -40°C to +85°C.

Shipping Weight: 1.0 pound (0.5Kg), packed.

TERMINATION PANEL: MODEL 5025-288

Type: Termination Panel For 68 Pin SCSI-3 Cable Connection

Application: To connect field I/O signals to the board. *Termination Panel:* Acromag Part 4001-066. The 5025-288 termination panel facilitates the connection of up to 68 field I/O signals and connects to the board (connectors only) via a round shielded cable (Model 5028-432). Field signals are accessed via screw terminal strips. The terminal strip markings on the termination panel (1-68) correspond to field I/O (pins 1-68) on the board. Each board has its own unique pin assignments. Refer to the board manual for correct wiring connections to the termination panel.

Schematic and Physical Attributes: See Drawing 4501-920.

Field Wiring: 68-position terminal blocks with screw clamps. Wire range 12 to 26 AWG.

Mounting: Termination panel is snapped on the DIN mounting rail.

Printed Circuit Board: Military grade FR-4 epoxy glass circuit board, 0.063 inches thick.

Operating Temperature: -40°C to +100°C.

Storage Temperature: -40°C to +100°C.

Shipping Weight: 1.0 pounds (0.5kg) packaged.

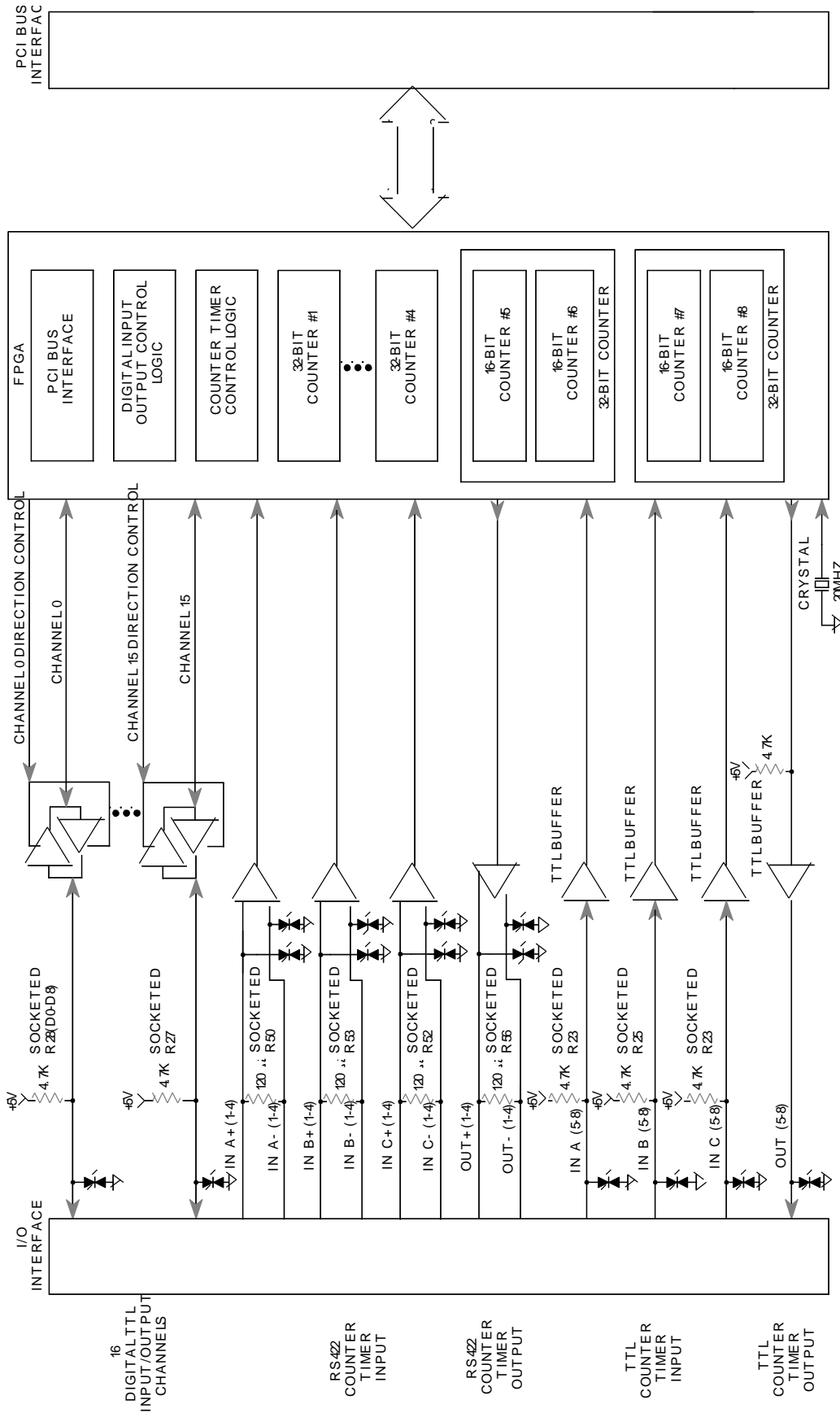

PMC, APC, AcPC483 BLOCK DIAGRAM

4501-953A

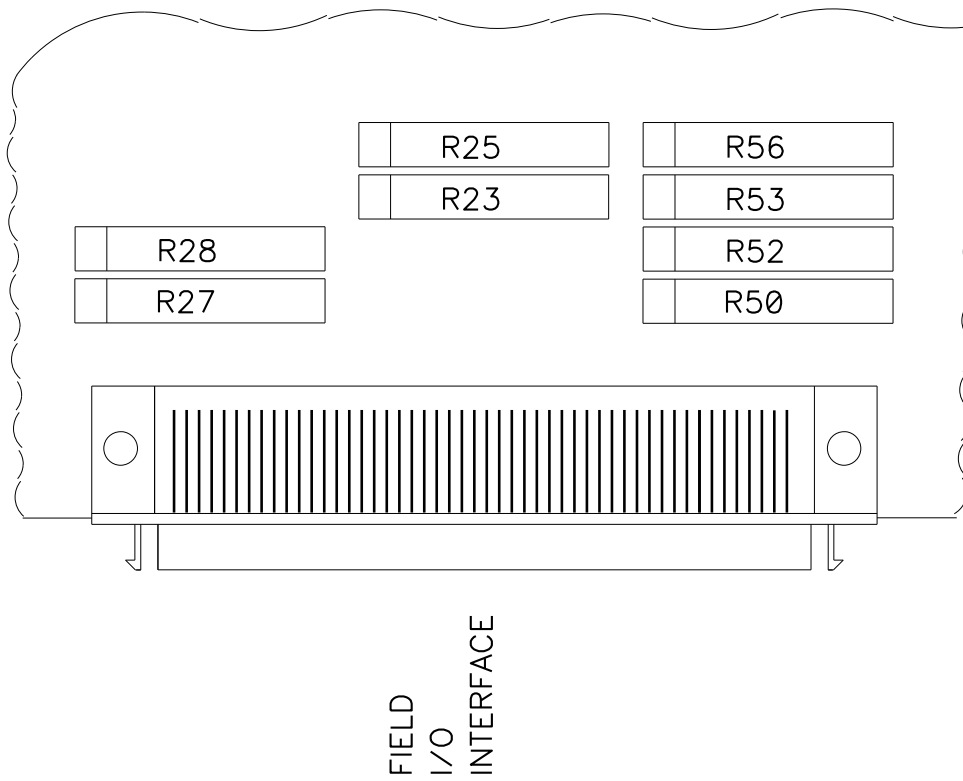

COMPONENT SIDE VIEW

PMC, APC, AcPC483 RESISTOR LOCATIONS 4501-954A

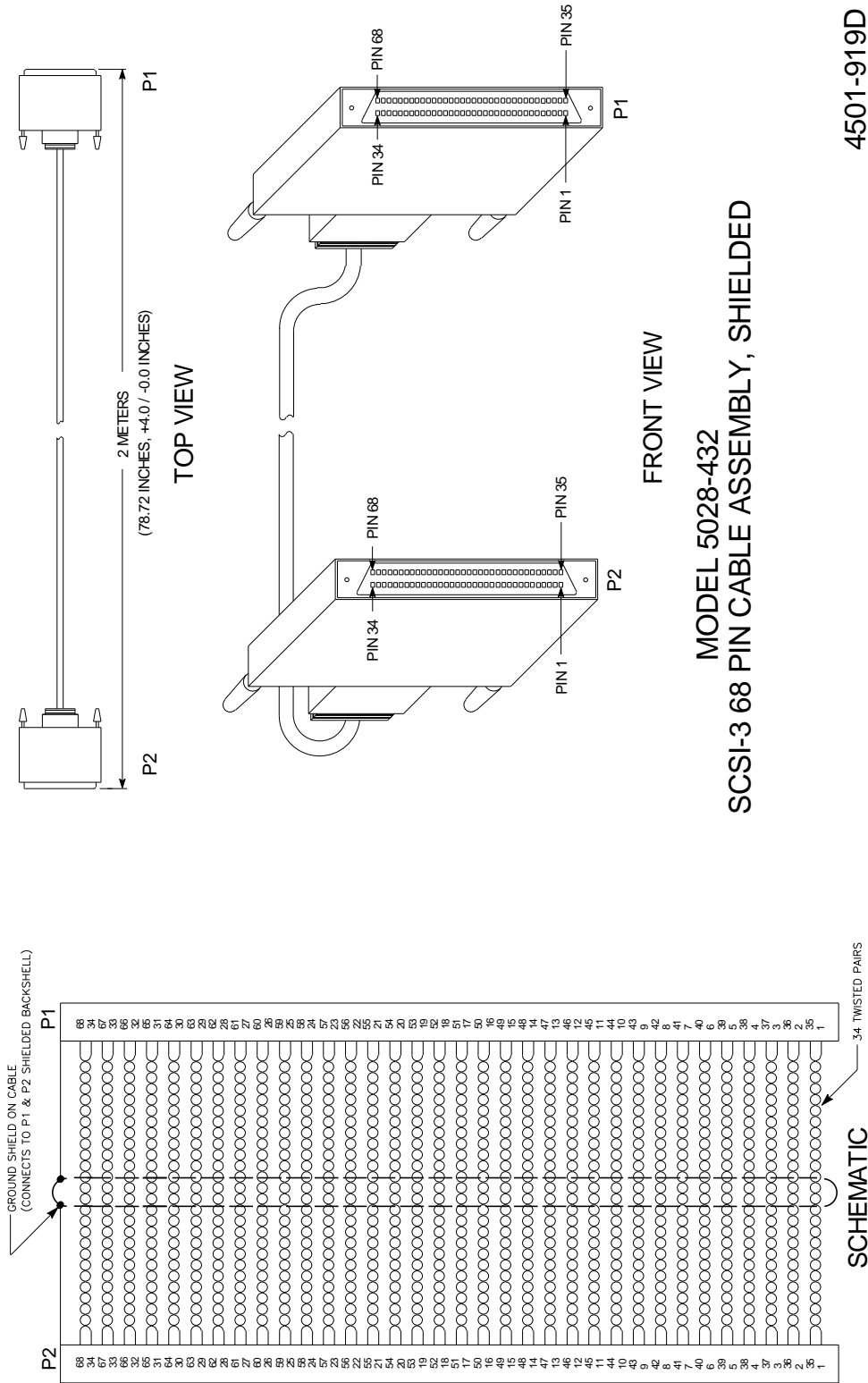

MODEL 5028-432
SCSI-3 68 PIN CABLE ASSEMBLY, SHIELDED

4501-919D

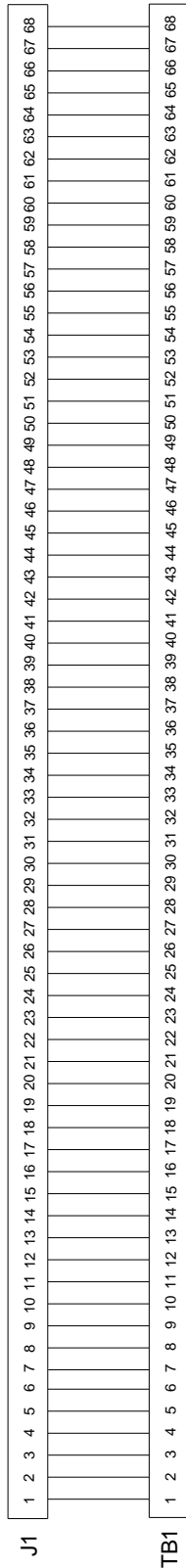

MODEL 5025-288 TERMINATION PANEL SCHEMATIC

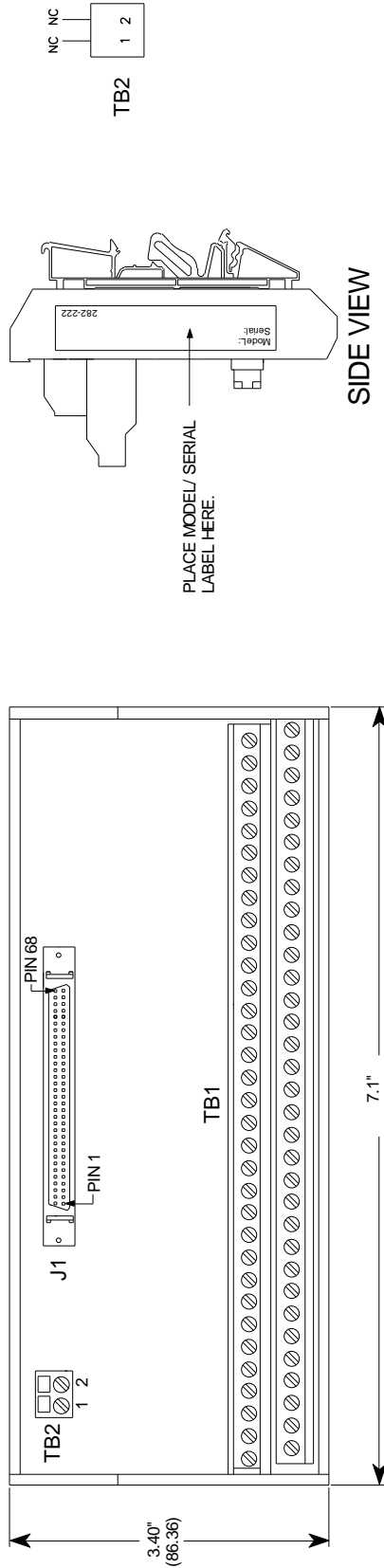

NOTE: DIMENSIONS ARE IN INCHES (MILLIMETERS)

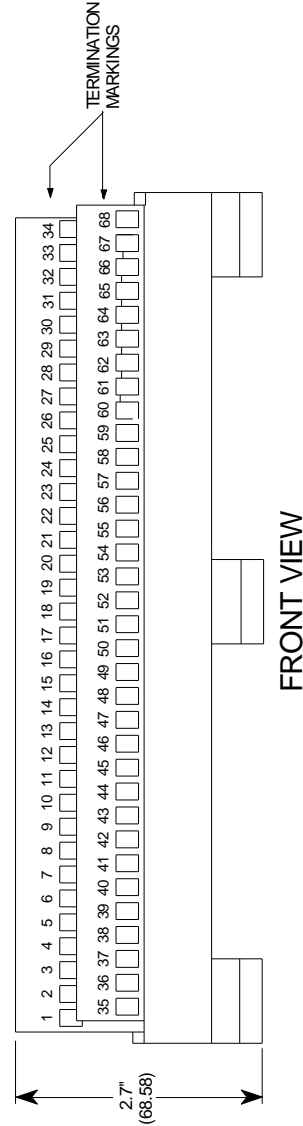

4501-920C

NOTES:

Revision History

The following table details the revision history for this document:

Release Date	Version	EGR/DOC	Description of Revision
3-AUG-2017	E	CAP/JAA	Remove CE Mark due to non-RoHS compliant part. Refer to ECN# 17G016.