



Using Acromag's AC Current Sensor Model 5020-350

Several Acromag transmitters with DC current input can be used in conjunction with an external AC Current Sensor to precondition an AC current input signal. This sensor is a highly accurate toroidal instrument transformer that converts an AC current signal to a safe, low-level, DC milliampere signal (0 to 11.17mA).

The transmitters only accept the isolated low-level signal produced by the AC current sensing transformer and cannot be connected directly to the source of AC power without damage or safety risk. The AC Current Sensor is fully insulated and designed for mounting near the source of the AC current. The input AC current range is a simple function of the number of turns placed on the AC Current Sensor (see the table below). The benefits to using an external sensor (external from the transmitter) include the following:

- **Low losses:**

It is not practical to run AC currents over long distances because of significant resistance voltage drops at high currents. The low-level DC milliampere signal output from the AC Current Sensor can be transmitted safely over long distances, allowing the transmitter to be remotely located from the AC power wiring.

- **Safety:**

The AC Current Sensor's output leads can be open or short circuited and these conditions do not affect the AC current loop or cause damage to the sensor. Likewise, the wires connecting the AC Current Sensor to the transmitter can be easily removed from the transmitter's input terminals without concern or hazard.

- **Ease of Calibration:**

The AC current input range can be easily scaled in the field by simply changing the number of primary turns at the sensor, with no additional calibration required. That is, the AC current input span is a simple function of the number of primary turns placed on the AC Current Sensor and sensor/transmitter calibration is not affected by this. Refer to Applications "A" & "B" of the diagrams on the next page.



Acromag's Flat Pack transmitters are shown with the AC current sensor toroidal transformer.

Sensor Primary Turns	AC Current Input Range	Sensor Output (red/black wires)
1	0 to 20 Amps AC	0 to 11.17mA DC
2	0 to 10 Amps AC	0 to 11.17mA DC
4	0 to 5 Amps AC	0 to 11.17mA DC
10	0 to 2 Amps AC	0 to 11.17mA DC
20	0 to 1 Amps AC	0 to 11.17mA DC

The AC Current Sensor is isolated and can be used in AC circuits up to 250V AC, 50 or 60 Hz. It is designed to be mounted at the source of the AC current to be measured. The transmitter can be located remotely from the AC signal and wired using small gauge wire. The sensor's output wires can be shorted, open-circuited, or removed from the transmitter's input terminals, without hazard to personnel or the AC Current sensor.

DANGER:

If the AC Current Sensor is used with an AC Current Transformer (C.T.), disconnect power to the C.T., or short the output of the C.T., before removing the wire going through the AC Current Sensor. If this is not done, an open circuited C.T. will generate high voltages (hazardous) and possible C.T. damage.

The output wires of the sensor are polarized: the Red wire is (+) plus and the Black wire is (-) minus. Normally, these output wires are attached to one end of a cable (user supplied) and the other end connects to the transmitter's input. Connect the Current Sensor output leads to the transmitter input by connecting Red (+) to the transmitter's plus (+) terminal, and Black (-) to the transmitter's minus (-) terminal. Proper polarity must be observed.

WARNING:

The input to the module can only come from the AC Current Sensor output wires (red/black). If AC current is directly attached to the transmitter's input terminals, the transmitter will be destroyed and safety compromised.

For most applications, it is recommended that the minus (-) transmitter input terminal be connected to an earth ground. The connections between the AC Current Sensor would be floating if not grounded. Grounding eliminates the risk of high common-mode voltages from showing up on the wires and reduces noise pickup.

Supported Products

- IntelliPack Series Transmitters and Alarms
- 610T Series Isolated Transmitters
- Flat Pack 250T/350T/450T Series Transmitters and 361A/461A Series Alarms



Dimensions and Electrical Connections

CAUTION: DO NOT CONNECT AC CURRENT DIRECTLY TO MODULE INPUT TERMINALS

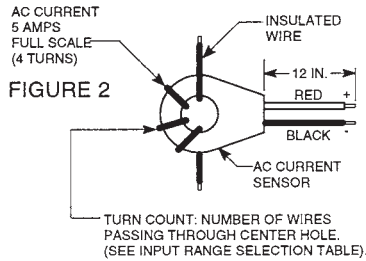
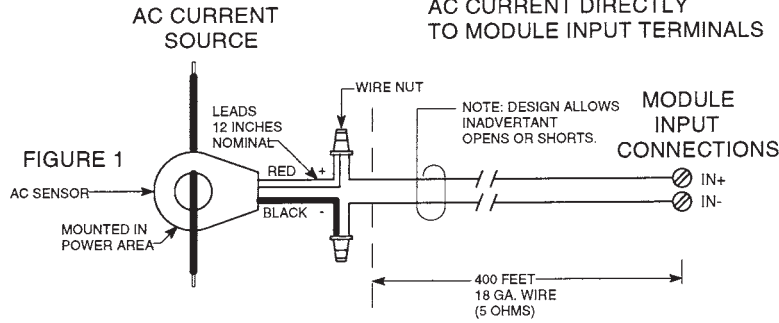
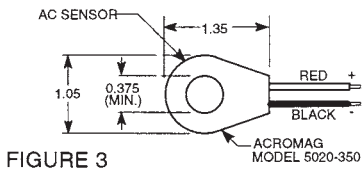

TABLE 1: TURNS CHART

INPUT RANGE SELECTION	
INPUT RANGE (RMS)	TURNS
0 TO 20A	1
0 TO 10A	2
0 TO 5A	4
0 TO 2A	10
0 TO 1A	20



ACROMAG
MODEL 5020-350

THIS SENSOR IS USED WITH VARIOUS ACROMAG INPUT MODULES - PLEASE REFERENCE THE USER'S MANUAL FOR THE MODULE FOR ADDITIONAL INFORMATION.



Application Examples

APPLICATION EXAMPLE A: AC CURRENT TRANSFORMER (C.T.)

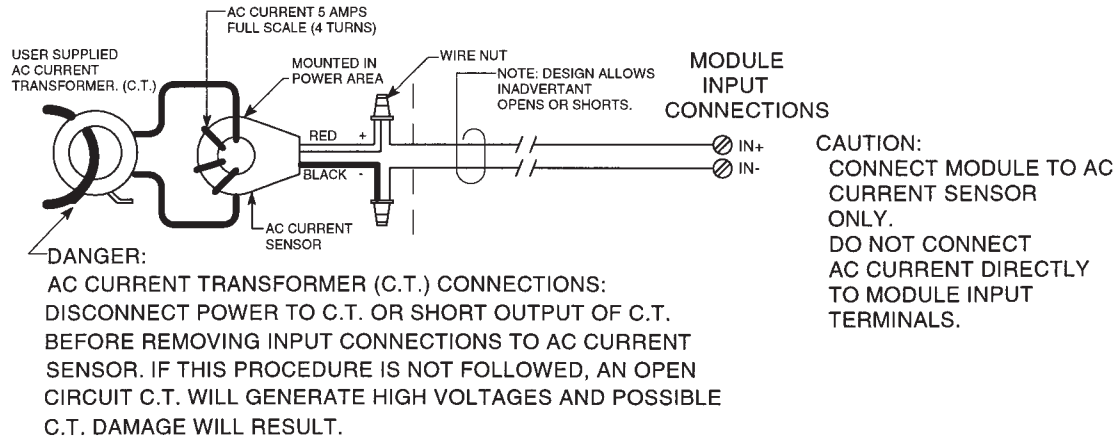

APPLICATION EXAMPLE B: 115V/230VAC ELECTRICAL CIRCUIT

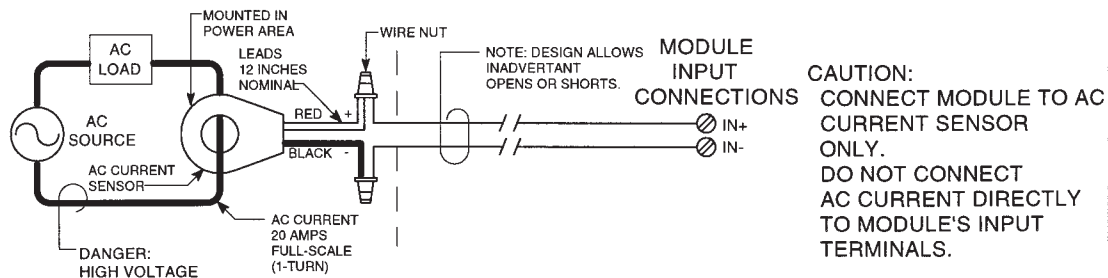

MODEL 5020-350 AC CURRENT SENSOR ELECTRICAL CONNECTIONS