



**IntelliPack Series 822A Alarms
Dual TC/mV Inputs**

USER'S MANUAL

ACROMAG INCORPORATED

**30765 South Wixom Road
Wixom, MI 48393-2417 U.S.A.**

Tel: (248) 624-1541

Fax: (248) 624-9234

Copyright 1997, Acromag, Inc., Printed in the USA.
Data and specifications are subject to change without notice.

8500566G

Safety Summary - Symbols on equipment:



Means "Caution, refer to this manual for additional information".

The information contained in this manual is subject to change without notice. Acromag, Inc., makes no warranty of any kind with regard to this material, including, but not limited to, the implied warranties of merchantability and fitness for a particular purpose. Further, Acromag, Inc., assumes no responsibility for any errors that may appear in this manual and makes no commitment to update, or keep current, the information contained in this manual. No part of this manual may be copied or reproduced in any form, without the prior written consent of Acromag, Inc.

Table of Contents	Page
1.0 INTRODUCTION	2
DESCRIPTION	2
Key IntelliPack 822A Features	3
ACCESSORY ITEMS	3
IntelliPack Configuration Software	3
IntelliPack Serial Port Adapter	3
IntelliPack Cable.....	4
IntelliPack Interface Package.....	4
2.0 PREPARATION FOR USE	4
UNPACKING AND INSPECTION	4
INSTALLATION	4
Mounting	4
Electrical Connections	4
3.0 MODULE CONFIGURATION	5
FIELD CONFIGURATION	5
4.0 THEORY OF OPERATION	6
5.0 SERVICE AND REPAIR	6
SERVICE AND REPAIR ASSISTANCE	6
PRELIMINARY SERVICE PROCEDURE	7
6.0 SPECIFICATIONS	7
MODEL NUMBER DEFINITION.....	7
INPUT SPECIFICATIONS	7
SPDT ALARM OUTPUT SPECIFICATIONS	8
SPDT Alarm Relay Specifications	8
ENCLOSURE/PHYSICAL SPECIFICATIONS	8
APPROVALS	8
ENVIRONMENTAL SPECIFICATIONS	8
FIELD CONFIGURATION & CONTROLS.....	9
HOST COMPUTER COMMUNICATION.....	9
SOFTWARE CONFIGURATION.....	9

List of Drawings	Page
Simplified Schematic & Contact Protection (4501-626)...	12
Functional Block Diagram (4501-693).....	13
Computer to IntelliPack Connections (4501-635)	14
Electrical Connections (4501-639).....	15
Interposing Relay Connections (4501-634)	16
Enclosure Dimensions (4501-631).....	17
REVISION HISTORY	18

IMPORTANT SAFETY CONSIDERATIONS

It is very important for the user to consider the possible adverse effects of power, wiring, component, sensor, or software failures in designing any type of control or monitoring system. This is especially important where economic property loss or human life is involved. It is important that the user employ satisfactory overall system design. It is agreed between the Buyer and Acromag, that this is the Buyer's responsibility.

1.0 INTRODUCTION

These instructions cover hardware functionality of the alarm model listed in Table 1. Supplementary sheets are attached for units with special options or features.

Table 1: Models Covered in This Manual

Series/ Input/Type	-Options/Output/ Enclosure/Approvals ¹	-Factory Configuration ²
822A	-0200	-C (Optional ²)

Notes (Table 1):

- Agency approvals include cULus Listed.
- Include the "-C" suffix for optional factory configuration. See Factory Configuration Order Form 8500-586 for this model. Otherwise, no suffix is required for standard configuration.

Module programming, alarm operation, and the IntelliPack Configuration Software are covered in the IntelliPack Alarm Configuration Manual (8500-563).

DESCRIPTION

The Series 822A Alarm is another member of the popular Acromag IntelliPack Alarm & Transmitter family. This model accepts two channels of DC millivoltage or thermocouple (TC) input signals, and provides two Single-Pole Double-Throw (SPDT) electromechanical alarm relays. Each IntelliPack module contains an advanced technology microcontroller with integrated downloadable flash memory and EEPROM for non-volatile program, configuration, calibration, and parameter data storage. Units are fully reprogrammable via our user-friendly Windows 95[®] or NT[®] IntelliPack Configuration Program. In-field reconfiguration is also possible with module push buttons and status LED's. Once configured, these modules may operate independent of the host computer for reliable embedded monitoring and control.

The 822A provides two input channels for either DC millivoltage or thermocouple signals. Thermocouple reference-junction compensation, linearization, and open circuit or TC break detection is included. Limited channel-to-channel isolation is achieved by alternately switching the input signals to an A/D converter via solid-state relays.

IntelliPack alarms use a high resolution, low noise, Sigma-Delta, Analog to Digital Converter ($\Sigma\Delta$ ADC) to accurately convert the input signal into a digitized value. User-defined alarm setpoints are compared to this digitized value and used to control the built-in alarm relays. Each relay may have high or low setpoints plus deadband configured. Both the alarm setpoints and deadband may be adjusted over the full input range of the unit. Relay actuation is user-selected for failsafe or non-failsafe operation. Relays may also be configured as latching, in which case a push button reset is required to reset the latch (this may also be accomplished via software control). Additionally, a programmed relay time delay may be applied to filter transients and minimize nuisance alarms. Each relay has a yellow LED on the front of the module that provides a visual indication of the high or low alarm condition. Green "Run" and yellow "Status" LED's provide local feedback of the operating mode, field configuration status, and system diagnostics. Front panel push buttons are provided to reset a latched alarm and to facilitate field reconfiguration in the absence of a host computer.

Windows 95 & NT are registered trademarks of Microsoft Corp.

Wide alarm functionality and convenient reprogrammability makes these alarms extremely powerful and flexible over a wide range of applications. These models may be configured as limit alarms, window alarms, on/off controllers, deviation alarms, peak detect alarms, and rate-of-change alarms. Other functions are possible (consult the factory).

All IntelliPack modules are designed to withstand harsh industrial environments. They feature RFI, EMI, ESD, EFT, and surge protection, low temperature drift, wide ambient temperature operation, and isolation from inputs to power and relay contacts. As a wide-range DC-powered device, these units may be powered from DC-power networks incorporating battery back-up. Additionally, the input power terminal is diode-coupled, providing reverse polarity protection. This allows the unit to be connected to redundant power supplies, or several units to safely share a single DC supply.

Units are DIN rail mounted and removable terminal blocks facilitate ease of installation or replacement, without having to remove wiring. Alarm relay and power wiring are inserted at one side of the unit, while input wiring is inserted at the other side. Connectors are an industry standard screw clamp type and accept a wide range of wire sizes.

The safe, compact, rugged, reconfigurable, and reliable design of this alarm makes it an ideal choice for control room and field applications. Custom alarm configurations are also available (please consult the factory).

Key IntelliPack 822A Features

- **Agency Approvals** - cULus Listed.
- **Windows® Configuration** - Fully reconfigurable via our user friendly Windows 95® or NT® Configuration Program.
- **Nonvolatile Reprogrammable Memory** - This module has an advanced technology microcontroller with integrated, non-volatile, downloadable flash memory and EEPROM.
- **Convenient Field Reprogrammability** - The unit includes push-button reconfiguration of key alarm functions in combination with status LED's to facilitate in-field changes without having to connect a host computer.
- **Wide Alarm Functionality** - The unit is programmable for a wide range of alarm types including limit, window, on/off controller, deviation, peak detection, or rate-of-change alarms. Other functions are possible (consult the factory).
- **Flexible DC Voltage or Thermocouple Inputs** - Accepts either DC voltage or thermocouple (TC) input signals. Linearization, upscale/downscale break detection, and TC reference-junction compensation are included.
- **High-Power SPDT Relays** - The module includes two single-pole-double-throw (SPDT) electro-mechanical relays for switching voltages to 230VAC at currents up to 5A.
- **Fully Isolated** - Inputs, power, & relay contacts are all isolated from each other for safety and increased noise immunity. Limited channel-to-channel isolation is also provided.
- **Self-Diagnostics** - Built-in routines operate upon power-up for reliable service, easy maintenance, and troubleshooting.
- **LED Indicators** - A green LED indicates power. A yellow status LED will turn on if input signal is out of range or the sensor is opened. A yellow alarm LED indicates when a relay is in alarm. These LED's also have other functions in field program mode.

Key IntelliPack 822A Features...continued

- **Wide Ambient Operation** - The unit is designed for reliable operation over wide ambient temperatures.
- **Individual Relay Functionality** - Each relay may be programmed for different functions.
- **Wide-Range DC-Powered** - This device receives power over a wide DC supply range and the power terminal is diode-coupled for reverse polarity protection. This makes this alarm useful for systems with redundant supplies and/or battery back-up power.
- **Hardened For Harsh Environments** - The unit will operate reliably in harsh industrial environments and includes protection from RFI, EMI, ESD, surges, and EFT, plus low radiated emissions per CE requirements.
- **Convenient Mounting, Removal, & Replacement** - DIN rail mounting and plug-in type terminal blocks make replacement and removal easy.
- **High-Resolution Precise A/D Conversion** - An advanced, high-resolution, low noise, Sigma-Delta, A/D Converter ($\Sigma\text{-}\Delta$ ADC) is included for high accuracy and reliability.
- **Upscale or Downscale TC Break Detection** - Input jumpers may select upscale or downscale break detection.
- **Failsafe or Non-Failsafe Relay Operation** - The unit may be configured for failsafe or non-failsafe relay operation.
- **Configurable Setpoint With Deadband** - Helps eliminate relay "chatter" and prolong contact life.
- **Configurable Latching or Momentary Alarms** - These alarms may be configured for automatic alarm reset, or as latching alarms with manual push-button or software reset.
- **Configurable Relay Time Delay Filters Transients** - Useful for increased noise immunity and to filter transients.

ACCESSORY ITEMS

The following IntelliPack accessories are available from Acromag. Acromag also offers other standard and custom alarm and transmitter types to serve a wide range of applications (please consult the factory).

IntelliPack Configuration Software (Model 5030-881)

IntelliPack alarms and transmitters are configured with this user-friendly Windows 95® or NT® Configuration Program. This software also includes the IntelliPack Alarm Configuration Manual (8500-563) and IntelliPack Transmitter Configuration Manual (8500-570). These manuals describe software operation and various alarm and transmitter functions in detail. On-line help is also built-in. All alarm and transmitter functions are programmable and downloadable to IntelliPack modules via this software. Non-volatile memory provides program, configuration, and data storage within the IntelliPack.

IntelliPack Serial Port Adapter (Model 5030-913)

This adapter serves as an isolated interface converter between the EIA232 serial port of the host computer and the Serial Peripheral Interface (SPI) port of the IntelliPack module. It is used in conjunction with the Acromag IntelliPack Configuration Software to program and configure the modules. This adapter requires no user adjustment, no external power, and operates transparent to the user. It receives its power from the IntelliPack module. The adapter has a DB9S connector that mates to the common DB9P serial port connector of a host computer.

The adapter also has a 6-wire RJ11 phone jack to connect to the IntelliPack alarm module via a separate interconnecting cable (described below). Refer to Drawing 4501-635 for computer to IntelliPack connection details.

IntelliPack Cable (Model 5030-902)

This 6-wire cable is used to connect the SPI port of the IntelliPack Serial Port Adapter to the IntelliPack. This cable carries the SPI data and clock signals, reset signal, and +5V power and ground signals. The cable is 7 feet long and has a 6-wire RJ11 plug at both ends which snap into jacks on the Serial Port Adapter and the IntelliPack module.

IntelliPack Software Interface Package (Model 800C-SIP)

The IntelliPack Interface Package combines the Configuration Software (5030-881), Alarm Configuration Manual (8500-563), Transmitter Configuration Manual (8500-570), Serial Port Adapter (5030-913), and Cable (5030-902), into a complete kit for interfacing with IntelliPack Alarms and Transmitters.

2.0 PREPARATION FOR USE

UNPACKING AND INSPECTION

Upon receipt of this product, inspect the shipping carton for evidence of mishandling during transit. If the shipping carton is badly damaged or water stained, request that the carrier's agent be present when the carton is opened. If the carrier's agent is absent when the carton is opened and the contents of the carton are damaged, keep the carton and packing material for the agent's inspection.

For repairs to a product damaged in shipment, refer to the Acromag Service Policy to obtain return instructions. It is suggested that salvageable shipping cartons and packing material be saved for future use in the event the product must be shipped.

This module is physically protected with packing material and electrically protected with an anti-static bag during shipment. However, it is recommended that the module be visually inspected for evidence of mishandling prior to applying power.

This circuit utilizes static sensitive components and should only be handled at a static-safe workstation.



INSTALLATION

The alarm module is packaged in a general purpose plastic enclosure. Use an auxiliary enclosure to protect the unit in unfavorable environments or vulnerable locations. Stay within the specified operating temperature range for best performance. As shipped from the factory, this unit has a default configuration and factory calibration as shown in Table 2:

WARNING: Applicable IEC Safety Standards may require that this device be mounted within an approved metal enclosure or sub-system, particularly for applications with voltages greater than or equal to 75VDC or 50VAC.

Table 2: 822A Default Factory Configuration

PARAMETER	CONFIGURATION	
	INPUT 1	INPUT 2
Range	TC Type J, -210°C to +760°C	TC Type J, -210°C to +760°C
Temp Units	°C	°C
Alarm Type	Limit	Limit
CJC	Enabled	Enabled
	ALARM 1	ALARM 2
Mode	High Limit	Low limit
Setpoint	200°C	100°C
Deadband	1°C	1°C
	RELAY 1	RELAY 2
Time Delay	200ms	200ms
Operating Mode	Failsafe	Failsafe
Reset	Auto (Momentary)	Auto (Momentary)

Your application may differ from the default configuration and will require that the alarm be reconfigured to suit your needs. This is accomplished with Acromag's user-friendly Windows 95®/NT® Configuration Program and Serial Port Adapter. Configuration is normally done prior to field installation since field configurability via the module's push-buttons is generally limited to setpoint and deadband adjustments where applicable. See the Alarm Configuration Manual 8500-563 for instructions. Note that upscale or down-scale break detection is configured via external jumpers at the input (see Drawing 4501-639). These jumpers are not present (no break detection) as received from the factory and the unit has been factory calibrated without break detection.

Mounting: Refer to the Enclosure Dimensions Drawing 4501-631 for alarm mounting and clearance dimensions.

DIN Rail Mounting: This module can be mounted on "T" type DIN rails. Use suitable fastening hardware to secure the DIN rail to the mounting surface. Units may be mounted side-by-side on 1-inch centers for limited space applications.

"T" Rail (35mm), Type EN50022: To attach a module to this style of DIN rail, angle the top of the unit towards the rail and locate the top groove of the adapter over the upper lip of the rail. Firmly push the unit towards the rail until it snaps solidly into place. To remove a module, first separate the input terminal block(s) from the bottom side of the module to create clearance to the DIN mounting area. Next, insert a screwdriver into the lower arm of the DIN rail connector and use it as a lever to force the connector down until the unit disengages from the rail.

Electrical Connections

All terminal strips can accommodate wire from 14-24 AWG (stranded or solid copper). Input terminals can use 14-22 AWG wire. Strip back wire insulation 1/4-inch on each lead before installing into the terminal block. Input wiring may be shielded or unshielded twisted pair. Since common mode voltages can exist on signal wiring, adequate wire insulation should be used and proper wiring practices followed.

It is recommended that alarm contacts and power wiring be separated from the input signal wiring for safety, as well as for low noise pickup. Note that input, power, and relay terminal blocks are plug-in type and can be easily removed to facilitate module removal or replacement without removing individual wires. TC inputs require two small jumpers at the input terminals to select upscale or downscale break detection (see Drawing 4501-639). Before calibrating an input, be sure that these jumpers are either configured or removed, as required by your application. Small measurement errors may occur if the jumpers are changed after input calibration. Factory units are calibrated and shipped without these jumpers. Be sure to remove power and/or disable the load before unplugging the terminals to uninstall the module, installing or removing jumpers, or before attempting service. All connections must be made with power removed.

CAUTION: Risk of Electric Shock - More than one disconnect switch may be required to de-energize the equipment before servicing.

1. **Power:** Refer to Electrical Connections Drawing 4501-639. Variations in power supply voltage within rated limits has negligible effect on module accuracy. For supply connections, use No. 14 AWG wires rated for at least 75°C. The power terminal is diode-coupled for reverse polarity protection.
2. **Inputs:** Connect input(s) per Electrical Connections Drawing 4501-639. Observe proper polarity when making connections (see label for input type). Input-to-input isolation is limited to within the common-mode voltage range (up to 48V). Note that TC inputs require two small jumper wires at the input terminals to select upscale or downscale break detection. Be sure that these jumpers are either configured or removed, as required by your application and before attempting calibration. Small offset errors may occur if the jumpers are changed after input calibration.
3. **Output Contacts:** Wire relay contacts as shown in Electrical Connections Drawing 4501-639. See the "Alarm Relay Specifications" for power capacity. If necessary, an interposing relay can be used to switch higher currents as shown in Interposing Relay Connection Drawing 4501-634.

Electromechanical Relay Contact Protection: To maximize relay life with inductive loads, external protection is required. For DC inductive loads, place a diode across the load (1N4006 or equivalent) with cathode to (+) and anode to (-). For AC inductive loads, place a Metal Oxide Varistor (MOV) across the load. See Relay Contact Protection Drawing 4501-626 for details.

IMPORTANT: Noise and/or jitter on the input signal has the effect of reducing (narrowing) the instrument's deadband and may produce contact chatter. The long term effect of this will reduce the life of mechanical relays. To reduce this undesired effect, you should increase the effective deadband.
4. **Grounding:** See Electrical Connections Drawing 4501-639. The module housing is plastic and does not require an earth ground connection. However, there are mounting positions on the input terminals to connect a cable shield, plus earth ground. These connections are isolated from the input circuit and their use is recommended to minimize noise and help protect the unit from potentially damaging input transients.

WARNING: For compliance to applicable safety and performance standards, the use of shielded cable is recommended as shown in Drawing 4501-639. Further, the application of earth ground must be in place as shown in Drawing 4501-639. Failure to adhere to sound wiring and grounding practices may compromise safety & performance.

3.0 MODULE CONFIGURATION

The alarm module needs to be configured for your specific application. Complete configuration is done using Acromag's Windows 95® or NT® Configuration Program and the IntelliPack Serial Port Adapter. Configuration details are included in Alarm Configuration Manual 8500-563. Limited field configuration via the module's push-buttons and LED's is covered below.

FIELD CONFIGURATION

This program mode allows adjustment to key alarm parameters in the field, without having to connect a host computer. Field reprogrammability is accomplished via the alarm module's "SET" and "MODE" push buttons and LED's (see Drawing 4501-631). Field reconfiguration via these controls will vary depending on the alarm function (see Table 5).

Equipment Required

- An accurate input millivoltage source or thermocouple calibrator adjustable over the range required for setpoint and dropout (deadband). **Note:** For best results, the input source must be accurate beyond the required specifications. For voltage inputs, use a voltage source with an output impedance of 100Ω or less.

General Field Programming Procedure

The following procedure uses the corresponding relay LED indicators (constant ON or FLASHING) to indicate which relay parameters (relay 1 or 2) are being modified (see Table 5).

CAUTION: To avoid damage to the unit, do not insert sharp or oversized objects into the push-button switch openings. When depressing the push-buttons, use a blunt-tipped object and apply pressure gradually until you feel or hear the tactile response.

1. Connect a precision voltage source or thermocouple calibrator to the input, as required (see Drawing 4501-639).
2. Apply power and the module's green "Run" LED will light.
3. Press and hold the "MODE" push button until the green "Run" LED goes out, and the relay 1 LED **turns on** (see Table 5). In this mode, the unit is ready to accept an input for parameter 1 of relay 1 per Table 3 below. If you do not wish to change this parameter, skip to step 6.
4. Adjust the input source level for relay parameter 1 as shown in Table 3 according to your alarm function.

Table 3: Relay Config Parameter 1 Per Alarm Function

ALARM FUNCTION	PARAMETER 1
Limit Alarm	High or Low Setpoint Value
Window Alarm	High Setpoint Value
On/Off Controller	Controller "On" Setpoint Value
Deviation Alarm	Set the Deviation Amount (Use Proper Polarity between inputs)
Peak/Valley Detector	Peak/Valley Detect Start Value
Rate-of-Change Alarm	Rate-Of-Change Threshold

General Field Programming Procedure...continued

5. Press the "SET" push button to accept the relay 1 parameter indicated in Table 3. Note that each time "SET" is pressed, the yellow "Status" LED will flash once and the value at the input will be captured.
6. Press the "MODE" button one time and the relay 1 LED should start flashing (see Table 5). This indicates the unit is ready to accept the second parameter of relay 1 as shown in Table 4:

Table 4: Relay Config Parameter 2 Per Alarm Function

ALARM FUNCTION	PARAMETER 2
Limit Alarm	Setpoint Dropout Value
Window Alarm	Low Setpoint Value
On/Off Controller	Controller "Off" Setpoint Value
Deviation Alarm (Both Inputs Required)	Deviation Dropout Value
Peak/Valley Detector	Peak or Valley Dropout Value
Rate-of-Change	Dropout Rate for Rate-of-Change

7. Adjust the input source to the desired level.
8. Press the "SET" push button to accept the parameter noted in Table 4 for your alarm function. The module will use the difference between the two programmed parameters to calculate the deadband where applicable.
9. If two relays are being programmed, press the "MODE" push button again to complete the first relay's program cycle, then repeat steps 4-8 to configure parameters for relay 2 (the relay 2 LED will turn ON and the "Run" LED will still be OFF).
10. After configuring relay 1, and relay 2 (where applicable), press the "MODE" push button again to complete the program sequence and return to run mode. The green "Run" LED will turn ON. This indicates the unit has returned to operating mode and the yellow relay LED's will now reflect actual alarm status per your application.

Notes (Field Program Procedure):

1. To summarize, the green "Run" LED is turned off in field configuration mode. The yellow "Status" LED blinks each time "SET" is pressed during configuration mode to indicate that the current input level has been captured. The yellow relay LED's are ON or flashing according to the parameter being set and the relay being programmed in field configuration mode.
2. If the alarm is in field configuration mode and no push buttons are pressed after 2 minutes, then the alarm will return to normal operating mode, the green "Run" LED will light, and no changes will have been made to the configuration.
3. Latching alarms require a push button reset to exit the alarm state (this may also be accomplished under software control).
4. Deadband and latching relays have no application with respect to on/off controller functionality.
5. Rate-of-change units (e.g. volts per second) are software configured and cannot be changed in the field via the module's push-buttons.
6. Note that alarm operating functions may be selected on a per relay basis. For example, relay 1 could function as a "limit alarm" monitoring the input, while relay 2 (if present) functions as an "on/off controller" monitoring the input.

7. During field configuration of dual relay models, the relay LED will be ON or FLASHING, corresponding to the relay being programmed and the parameter being adjusted as in Table 5:

Table 5: Field Configuration Relay LED Mode Indication

ALARM FUNCTION	RELAY 1 or 2 LED	
	ON	FLASHING
Limit	HI/LO Setpoint	HI/LO Dropout
Window	High Setpoint	Low Setpoint
ON/OFF Controller	ON Setpoint	OFF Setpoint
Deviation Alarm	Deviation	Dropout
Peak/Valley Detect	P/V Detect Start	P/V Dropout
Rate-Of-Change	ROC Threshold	ROC Dropout

4.0 THEORY OF OPERATION

Refer to the block diagram of Drawing 4501-626 and the functional block diagram of Drawing 4501-693 to gain a better understanding of the circuit. Note that these alarms pre-filter the input signals and alternately connect each input to a precision A/D converter via solid state relays. By alternately connecting the inputs via solid-state switches, limited channel-to-channel isolation is achieved to within the common mode voltage range. The thermocouple reference junction signals connect to the A/D directly. The A/D converter stage then multiplexes the input and reference junction signals, applies appropriate gain, digitally filters the signal, and performs analog-to-digital conversion. The digitized signal is then transmitted serially to a microprocessor. The microprocessor compares the digitized signal to the limit value according to the alarm type and completes all necessary alarm functions per its embedded program. The program configuration and calibration parameters are stored in non-volatile memory integrated within the microprocessor. Only those functions required by an application are actually stored within memory and new functionality can be easily downloaded from a PC using the IntelliPack Configuration Software. A wide input switching regulator (isolated flyback mode) provides isolated +5V power to the circuit.

5.0 SERVICE AND REPAIR

CAUTION: Risk of Electric Shock - More than one disconnect switch may be required to de-energize the equipment before servicing.

SERVICE AND REPAIR ASSISTANCE

This module contains solid-state components and requires no maintenance, except for periodic cleaning and alarm configuration parameter (setpoint, deadband, etc) verification. Since Surface Mounted Technology (SMT) boards are generally difficult to repair, it is highly recommended that a non-functioning module be returned to Acromag for repair. The board can be damaged unless special SMT repair and service tools are used. Further, Acromag has automated test equipment that thoroughly checks and calibrates the performance of each module. Please refer to Acromag's Service Policy Bulletin, or contact Acromag for complete details on how to obtain parts and repair.

PRELIMINARY SERVICE PROCEDURE

Before beginning repair, be sure that all installation and configuration procedures have been followed. The unit routinely performs internal diagnostics following power-up or reset. During this period, all LED's will turn ON momentarily, and the green "Run" LED flashes. If the diagnostics complete successfully, the "Run" LED will stop flashing after two seconds and then remain ON. This indicates that the unit is operating normally. If the "Run" LED continues to flash, then this is indicative of a problem. In this case, use the Acromag IntelliPack Configuration Software to reconfigure the module and this will usually cure the problem. If the diagnostics indicate a problem via a continuously flashing green LED, or if other evidence points to a problem with the unit, an effective and convenient fault diagnosis method is to exchange the questionable module with a known good unit.

The IntelliPack Serial Port Adapter also contains a red LED visible at the small opening in the enclosure to the right of the RJ11 receptacle. If this LED is OFF or Flashing, then a communication interface problem exists. The adapter receives its power from the IntelliPack module. A constant ON LED indicates a properly working and powered serial interface adapter.

Acromag's Application Engineers can provide further technical assistance if required. When needed, complete repair services are available from Acromag.

6.0 SPECIFICATIONS

822A-0200-C, Dual mV/TC Inputs, Dual SPDT Relays

General: The IntelliPack Model 822A is a DC-powered dual alarm which conditions two channels of thermocouple or millivolt inputs, and provides two Single-Pole Double-Throw (SPDT) electromechanical alarm relays. Isolation is supplied between the input, the relay contacts, and power. This alarm is DIN-rail mounted.

The unit is configured and calibrated with our user-friendly Windows 95® or NT® IntelliPack Configuration Program. Push-buttons on the module allow field adjustment of setpoint and deadband (where applicable). All calibration and configuration information is stored in non-volatile reprogrammable memory in the module.

MODEL NUMBER DEFINITION

IntelliPack Alarms are color coded with a yellow label. The prefix "8" denotes the IntelliPack Series 800, while the "A" suffix specifies that outputs are alarm contacts.

822A: Monitors 2 DC millivoltage or thermocouple (TC) inputs.

-0200: The four digits of this model suffix represent the following options, respectively:

- 0 = Options: None (reserved for future use);
- 2 = Output: Two SPDT relays;
- 0 = Enclosure: DIN rail mount;
- 0 = Approvals: cULus Listed.

INPUT SPECIFICATIONS

The unit must be wired and configured for the intended input type and range (see Installation Section for details). The following paragraphs summarize this model's input types, ranges, and applicable specifications.

DC Voltage: User-configured for seven bipolar DC voltage ranges: $\pm 1.0\text{V}$; $\pm 500\text{mV}$; $\pm 250\text{mV}$; $\pm 125\text{mV}$; $\pm 62.5\text{mV}$; $\pm 31.3\text{mV}$; and $\pm 15.6\text{mV}$. See Table 7.

Voltage Input Reference Test Conditions: $\pm 15.6\text{mV}$ input range; Setpoint at 10mV ; Deadband = 0.5mV ; Alarm Type = Failsafe High Limit; Ambient Temperature = 25°C ; Power Supply = 24V DC ; Alarm Delay = 200ms .

Input bias current: $\pm 10\text{nA}$ maximum, $\pm 100\text{nA}$ typical with TC Break Detection.

Thermocouple: User configured for the eight types of thermocouples shown in Table 6. Supports J, K, T, R, S, E, B, and N types. Linearization, cold-junction compensation, and open circuit or lead break detection is included. See Table 6.

Table 6: TC Types, Ranges, and Accuracy

TC Type	TC Material	ISA/ANSI Color	°C Temp Range	Typical Accuracy
J	+Iron, -Constantan	white red	-210 to + 760°C	$\pm 0.5^\circ\text{C}$
K	+Chromel, -Alumel	yellow black	-200 to +1372°C	$\pm 0.5^\circ\text{C}$
T	+Copper, -Constantan	blue red	-260 to + 400°C	$\pm 0.5^\circ\text{C}$
R	+Pt/13%Rh, -Constantan	black red	- 50 to +1768°C	$\pm 1.0^\circ\text{C}$
S	+Pt/10%Rh, -Constantan	black red	- 50 to +1768°C	$\pm 1.0^\circ\text{C}$
E	+Chromel, -Constantan	purple red	-200 to +1000°C	$\pm 0.5^\circ\text{C}$
B	+Pt/10%Rh, -Pt/6%Rh	gray red	+260 to 1820°C	$\pm 1.0^\circ\text{C}$
N	+Nicrosil, -NISIL	orange red	-230 to -170°C; -170 to +1300°C	$\pm 1.0^\circ\text{C}$ $\pm 0.5^\circ\text{C}$

TC Input Reference Test Conditions: All TC types with 10mV setpoints (e.g. Type J at 0°C to 186°C); deadband = 1°C ; Alarm Type = Failsafe High Limit; Ambient = 25°C ; Power Supply = 24V DC ; Alarm Delay = 200ms .

TC Input Bias Current: $\pm 10\text{nA}$ maximum (TC/mV inputs), $\pm 100\text{nA}$ typical (with TC break detection).

Thermocouple Reference: Accurate to better than $\pm 0.4^\circ\text{C}$ typical at $25^\circ\text{C} \pm 0.01^\circ\text{C}$ per $^\circ\text{C}$ over temperature.

TC Linearization: Within $\pm 0.25^\circ\text{C}$ of the NIST tables.

TC Break Detection (Jumpers Required): Thermocouple failure (lead break) detection can be configured for upscale or downscale. For upscale, place jumpers between BKA & IN+ and BKB & IN- input terminals. For downscale, place jumpers between BKA & IN- and BKB & IN+ input terminals. Jumpers should be set or removed as required prior to input calibration.

General Input Specifications

Accuracy: For TC inputs, see Table 6. Voltage input accuracy is typically better than ±0.05%. Accuracy includes repeatability, linearization, & reference junction error (TC inputs), but does not include sensor error.
Accuracy Versus Temperature: Better than ±0.005% of input span per °C or ±1uV/°C, whichever is greater.
A/D Resolution: Resolution is given in Table 7 per range.
Internal Unit Resolution: ±0.005% of span or 0.1°C/lsb. The ADC typically yields resolutions finer than 0.1°C/lsb.

Table 7: Resolution Per Applicable Range

Range	Resolution
±15.6mV	0.78uV/LSB
±31.3mV	1.56uV/LSB
±62.5mV	3.125uV/LSB
±125mV	6.25uV/LSB
±250mV	12.5uV/LSB
±500mV	25uV/LSB
±1.0V	50uV/LSB
All Thermocouples	0.1°C (0.18°F)

Response Time: Less than 500ms typical to 98% of final value for a step change in input. Note a software configurable delay can be implemented for filtering transients and this will increase the response time.
Analog to Digital Converter (A/D): A 16-bit Σ-Δ converter, Analog Devices AD7714AR-5.
Input Filter: Normal mode filtering, plus digital filtering optimized & fixed per input range within the Σ-Δ ADC.
Input Bandwidth: Alarm contacts will track an input square wave to approximately 1.0Hz. Note that relay time delay can be implemented for filtering transients and this will lower the bandwidth.
Noise Rejection (Normal Mode): Better than 40dB @ 60Hz, typical with 100Ω input unbalance.
Noise Rejection (Common Mode): Better than 130dB @ 60Hz, typical with 100Ω input unbalance.
Input-to-Input Isolation: Inputs of this model may have up to ±48V common mode voltage between them.
Input Conversion Rate: 4 conversions per second. The unit samples each of 2 channels 5 times over a 2.25 second interval, or 225ms per channel.
Input Overvoltage Protection: Bipolar Transient Voltage Suppressors (TVS) at each lead, 7.6V and 16V clamp levels typical.

SPDT ALARM OUTPUT (-x2xx):

This model contains two independent SPDT electro-mechanical relays. Each relay contains high reliability, Form C (Normally Open and Normally Closed), SPDT contacts. One relay is assigned to each input and each relay may have different alarm functions assigned to it.

SPDT Alarm Relay Specifications:

Electrical Life - CSA Ratings:
 25VDC, 5A, 10⁵ operations, resistive.
 48VDC, 0.8A, 10⁵ operations, resistive.
 240VDC, 0.1A, 10⁵ operations, resistive.
 120VAC/240VAC, 5A, 3x10⁴ operations, resistive.
Note: To control a higher amperage device, such as a pump, an interposing relay may be used (see Interposing Relay Connections Drawing 4501-634).

Contact Material: Silver-cadmium oxide (AgCdO).
Initial Dielectric Strength: Between open contacts: 1000VAC rms.
Expected Mechanical Life: 20 million operations.
Note: External contact protection is required for use with inductive loads (see Contact Protection Drawing 4501-626). Failure to use adequate protection may reduce contact life or damage the unit.
Relay Response (No Relay Time Delay): Relay contacts will switch within 500ms for an input step change from 10% of span on one side of an alarm point to 5% of span on the other side of the alarm point.

ENCLOSURE/PHYSICAL SPECIFICATIONS

See Enclosure Dimensions Drawing 4501-631. Units are packaged in a general purpose plastic enclosure that is DIN rail mountable for flexible, high density (approximately 1" wide per unit) mounting.

Dimensions: Width = 1.05 inch, Height = 4.68 inches, Depth = 4.35 inches (see Drawing 4501-631).
DIN Rail Mounting (-xx0x): DIN rail mount, Type EN50022; "T" rail (35mm).
Connectors: Removable plug-in type terminal blocks rated for voltages and currents up to 300V and 15A (output & power), or 300V and 10A (inputs). Accommodates wires in range 14-24 AWG (output), or 14-22 AWG (input), stranded or solid copper. Separate terminal blocks are provided for each input, power & relay contacts. CJC terminal blocks (orange color) should not be removed or exchanged. For supply connections, use No. 14 AWG copper wires rated for at least 75°C.
Case Material: Self-extinguishing NYLON type 6.6 polyamide thermoplastic UL94 V-2, color beige; general purpose NEMA Type 1 enclosure.
Printed Circuit Boards: Military grade FR-4 epoxy glass.
Shipping Weight: 1 pound (0.45 Kg) packed.

APPROVALS (-xxx0)

0: Agency Approvals - cULus Listed, UL File E199702.
 Product approval is limited to the general safety requirements of the above standards.
Warning: This product is not approved for hazardous location applications.

ENVIRONMENTAL SPECIFICATIONS

Operating Temperature: -25°C to +70°C (-13°F to +158°F).
Storage Temperature: -40°C to +85°C (-40°F to +185°F).
Relative Humidity: 5 to 95%, non-condensing.
Power Requirements: +10V Minimum to +36V DC Maximum. Current draw is a function of the supply voltage (see Table 8). An internal diode provides reverse polarity protection. Currents shown are with the serial port adapter connected.

CAUTION: Do not exceed 36VDC peak, to avoid damage to the module.

Table 8: Supply Current (822A-0200 Models)

Supply Voltage	Supply Current (Relays Off)	Supply Current (Relays On)
10V	90mA	135mA
12V	70mA	110mA
15V	60mA	90mA
24V	40mA	60mA
36V	35mA	45mA

Note: Disconnecting the serial port adapter reduces current consumption by an average of 12%.

IMPORTANT – External Fuse: If unit is powered from a supply capable of delivering more than 1A to the unit, it is recommended that this current be limited via a high surge tolerant fuse rated for a maximum current of 1A or less (for example, see Bel Fuse MJS1).

Power Supply Effect:

DC Volts: Less than $\pm 0.001\%$ of input span change per volt DC for rated power supply variations.

60/120 Hz Ripple: Less than 0.01% of input span per volt peak-to-peak of power supply ripple.

Isolation: Input, relay contacts, and power are isolated from each other for common-mode voltages up to 250VAC, or 354V DC off DC power ground, on a continuous basis (will withstand 1500VAC dielectric strength test for one minute without breakdown). This complies with test requirements outlined in ANSI/ISA-82.01-1988 for the voltage rating specified. Note that input-to-input isolation is limited to common mode voltages up to $\pm 48V$ maximum.

Installation Category: Suitable for installation in a Pollution Degree 2 environment with installation category (over-voltage category) II rating.

Radiated Field Immunity (RFI): Designed to comply with IEC1000-4-3 Level 3 (10V/M, 80 to 1000MHz AM & 900MHz keyed) and European Norm EN50082-1.

Electromagnetic Interference Immunity (EMI): No relay trips will occur beyond $\pm 0.25\%$ of input span from setpoint under the influence of EMI from switching solenoids, commutator motors, and drill motors.

Electrical Fast Transient Immunity (EFT): Complies with IEC1000-4-4 Level 3 (2KV power; 1KV signal lines) and European Norm EN50082-1.

Surge Immunity: Complies with IEC1000-4-5 Level 3 (2.0KV) and European Norm EN50082-1.

Electrostatic Discharge (ESD) Immunity: Complies with IEC1000-4-2 Level 3 (8KV/4KV air/direct discharge) to the enclosure port and European Norm EN50082-1.

Radiated Emissions: Meets or exceeds European Norm EN50081-1 for class B equipment.

FIELD CONFIGURATION AND CONTROLS

Field programmability of key alarm functions (e.g. setpoint and deadband) is accomplished with module push buttons and LED indicators in the absence of a host computer. However, the unit must be initially configured using the IntelliPack Configuration Software before alarm setpoint or deadband can be changed in the field.

Module Push Buttons (See Dwg 4501-631 for Location):

Mode - Used to change mode of field configuration.

Set - Used to accept input data during field calibration.

Reset 1 - Used to reset a latched alarm for relay 1.

Reset 2 - Used to reset a latched alarm for relay 2.

LED Indicators (See Dwg 4501-631 for Location):

Operating Mode

Run (Green) - Constant ON indicates power is applied and unit is operating normally. Flashing ON/OFF indicates unit is performing diagnostics (first second following power-up) or has failed diagnostics (after a few seconds).

Status (Yellow) - Flashing ON/OFF indicates an over/under range condition exists at an input.

Relay 1 Alarm (Yellow) - Constant ON indicates alarm condition for relay 1. During field configuration, this LED has a different function (see below).

Relay 2 Alarm (Yellow) - Constant ON indicates alarm condition for relay 2. During field configuration, this LED has a different function (see below).

Field Configuration Mode

Run (Green) - Turned OFF in this mode.

Status (Yellow) - Blinks each time the SET push-button is pressed to capture an input signal in this mode.

Relay 1 Alarm (Yellow) - Constant ON or flashing ON/OFF indicates whether configuration parameter 1 or 2 of relay 1 is being programmed in this mode (see Table 5).

Relay 2 Alarm (Yellow) - Constant ON or flashing ON/OFF indicates whether configuration parameter 1 or 2 of relay 2 is being programmed in this mode (see Table 5).

HOST COMPUTER COMMUNICATION

Host Computer Communication: Configuration information is downloaded from the host computer through its EIA232 serial port. This port must be connected to the module through an IntelliPack Serial Port Adapter, which serves as an isolated interface converter between EIA232 and the IntelliPack SPI port (standard RJ11 6-wire phone jack).

Baud Rate (EIA232): 19.2K baud.

SOFTWARE CONFIGURATION

Units are fully programmable via our user-friendly Windows 95® or NT® IntelliPack Configuration Program (5030-881). A cable (5030-902) and converter (5030-913) are required to complete the interface (see Software Interface Package 800C-SIP). See Drawing 4501-635.

The following alarm attributes are programmable via the IntelliPack Configuration Software. Refer to the IntelliPack Alarm Configuration Manual (8500-563) for a more detailed explanation of these attributes and their application.

Input 1 & Input 2 Configuration

Input - Range: The alarm can be configured to accept any of the input types/ranges described in the Input Specifications using the IntelliPack Configuration Software.

Input - Temperature Units: Can be configured to use °C, °F, or K units.

Input - Alarm Type: Select Limit Alarm, Window Alarm, On/Off Controller, Deviation Alarm, Peak/Valley Detector, or Rate-of-Change Alarm (see description in Alarm Configuration).

Input - CJC (Cold Junction Compensation): Thermocouple units only. Must be set to ON when directly connecting a thermocouple to the module (default). The CJC can be set to OFF when connecting a millivolt source, representing temperature, directly to the module's input terminals.

Input Calibration: The configuration software can be used to calibrate each input circuit of this module and restore a module's original factory input calibration in case of miscalibration. Each channel's temperature reference circuit (CJC) may also be calibrated and the original factory CJC calibration may be restored in case of miscalibration.

Note: Before calibrating a TC input with CJC ON, allow the module to warm-up for at least 10 minutes for best performance. Also, be sure to calibrate the unit with the input upscale or downscale jumpers already installed, or removed, as required by your application. Units are factory calibrated without break detection.

Alarm 1 & Alarm 2 Configuration

Each input of this model may be configured for one of six different alarm types/operating functions:

Alarm Operating Functions: The following gives a brief description of current available alarm operating functions for this model. Other modes are possible (consult the factory).

Limit Alarm: Limit alarms have only a single high or low setpoint applied to an input at a time. The relay will enter the alarm state when either the user-defined high or low setpoint is exceeded for the specified amount of time. Relay remains in alarm until the input has retreated past the setpoint, plus any deadband, for the specified amount of time.

Window: Window alarms have both high and low setpoints on an input at a time. The relay will enter the alarm state when either the user-defined high or low setpoint is exceeded for the specified amount of time. Relay remains in alarm until the input signal has retreated past the defined setpoint, plus any deadband, for the specified amount of time.

On/Off Controller: The relay will enter the alarm state when the "on" setpoint has been exceeded for the specified amount of time. Relay remains in alarm until the input signal has retreated past the "off" setpoint (deadband does not apply) for the specified amount of time. Note latching relays are not applicable to On/Off Controllers.

Deviation (Both Inputs Required): The deviation alarm (positive, negative, or absolute) uses the difference between the inputs to generate an alarm condition. One input is selected to serve as the reference and the deviation of the other input is measured from this. Positive deviation is determined via (input1-input2), negative deviation via (input2-input1), and absolute deviation is determined via the absolute value of [input1-input2]. The relay will enter the alarm state when the deviation limit has been exceeded for the specified amount of time. The relay remains in the alarm state until the signal has retreated to within the deviation limit, plus any deadband, for the specified amount of time.

Peak/Valley Detection: An alarm condition is produced for a user defined peak (max) or valley (min) condition of the desired input signal. The peak/valley detection function will not activate until the input signal has exceeded the user-specified peak or valley start sensing level for the user-specified amount of time delay.

Once the peak/valley function has been activated, the input is monitored to detect a retreat in the input by an amount specified as the deadband value. When this occurs, the relay will enter the alarm state (no delay applies). The relay remains in the alarm state until the signal has further retreated beyond a user specified deactivate value (no delay applies). Note that if the start value is greater than the deactivate value, then a peak condition will be detected. Otherwise, a valley detection will be made.

Rate-of-Change: The relay will enter the alarm state when the programmed rate-of-change threshold value is exceeded by the input signal's rate-of-change. The relay remains in the alarm state until the input signal's rate-of-change has retreated below a user specified dropout rate-of-change value. The input signal rate-of-change is calculated as a running average of 2 samples over a 1 second time interval (this allows input transients to be filtered). The module always monitors the absolute rate of change in the input signal and will activate with either a positive or negative rate-of-change. The rate-of-change threshold and dropout values may be adjusted in the field via the module's push-buttons and LED's (units/second are selected during host computer configuration).

Alarm - Input: The input signal range to the alarm is the full range for the configured input type. Example: If a Type J thermocouple was selected, then the alarm can be programmed to any setpoint from -200°C to +760°C via the configuration program.

Alarm - Mode: Select a High or Low limit for the limit alarm function. The relay will trip on an increasing input signal for a high limit, and on a decreasing input signal for a low limit.

Alarm - Setpoint: A high or low setpoint (plus deadband) may be assigned to each relay and is programmable over the entire input range. The relay will enter the alarm state when either the user-defined high or low setpoint is exceeded for the specified amount of time (this allows input transients to be filtered). The relay will trip on an increasing input signal for a high setpoint, and on a decreasing input signal for a low setpoint. Relay remains in the alarm state until the input signal has retreated past the defined setpoint, plus any deadband, for the specified amount of time.

Alarm - Deadband: Deadband is associated with each setpoint and is programmable over the entire input range. Deadband determines the amount the input signal has to return into the "normal" operating range before the relay contacts will transfer out of the "alarm" state. Deadband is normally used to eliminate false trips or alarm "chatter" caused by fluctuations in the input near the alarm point. Note that deadband may also apply to latched alarms. If the alarm is latching, it is recommended that the deadband be set to a minimum.

IMPORTANT: Noise and/or jitter on the input signal has the effect of reducing (narrowing) the deadband and may produce contact chatter. Another long term effect of contact chatter is a reduction in the life of mechanical relay contacts. To reduce this undesired effect, increase the deadband setting.

Alarm Indicators: One yellow LED per relay provides a visual status indication of when a relay is in alarm.

Relay - Time Delay: Programmable from 0 milliseconds to 4 seconds in 200ms increments for this model (used to help filter input transients and avoid nuisance alarming). A minimum delay of 200ms is recommended for increased noise immunity and to maintain conformance to applicable safety standards.

Relay - Operating Mode: User configurable for “failsafe” operation (relay deenergized in alarm state), or non-failsafe operation (relay energized in alarm state). Failsafe mode provides the same contact closure for alarm states as for power loss, while non-failsafe mode uses alarm contact closure opposite to power loss conditions.

Relay - Reset: Relays may be configured to automatically reset when the inputs retreat past their setpoints and deadband, or relays may latch into their alarm state. One push-button reset switch per relay is located on the front of the module and is used to exit the latched state (this may also be accomplished under software control). A latched relay cannot be reset until its input signal has returned into its normal operating range with deadband applied and after the relay time delay. Note that when the input returns to, or leaves the normal operating range, the relay and its LED will transfer after the relay time delay has expired. That is, time delay applies to both activating and deactivating the relay.

Notes:

Other IntelliPack Configuration Software Capabilities

In addition to configuring all features of the module described above, the IntelliPack Configuration Software includes additional capabilities for testing and control of this module as follows:

- Monitors the input signal values and alarm status and allows polling to be turned on or off. Also monitors the reference temperature of each channel's CJC circuit.
- Allows a configuration to be uploaded or downloaded to/from the module. Also provides a means to rewrite a module's firmware if the microcontroller is replaced or a module's functionality is updated.
- Provides controls to separately calibrate each input and temperature reference circuit. It also provides controls to restore the original factory input or reference calibration in case of error.
- Provides controls to reset a module.
- Provides controls to reset a latched alarm (same effect as a push-button alarm reset at the module).
- Allows optional user documentation to be written to the module. Documentation fields are provided for tag number, comment, configured by, location, and identification information. This information can also be uploaded from the module and printed via this software.
- Allows a module's complete configuration to be printed in an easy to read, one or two page format, including user documentation.

For complete information on the IntelliPack Configuration Software, refer to Alarm Configuration Manual 8500-563.

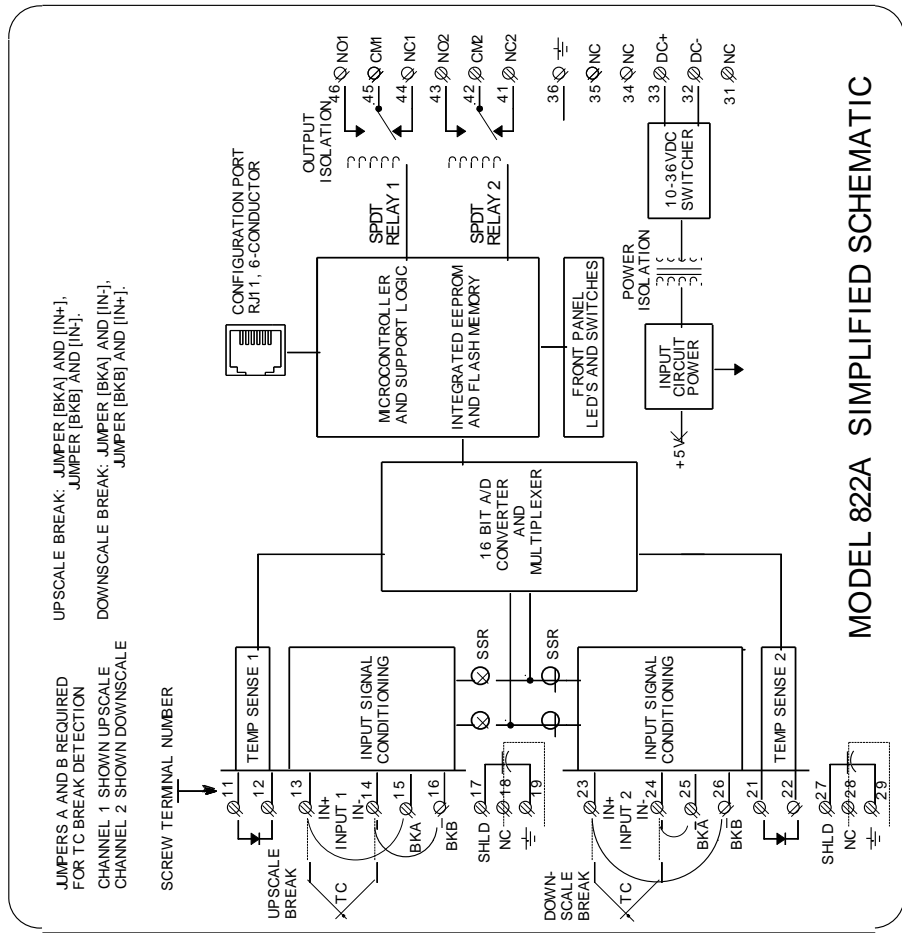
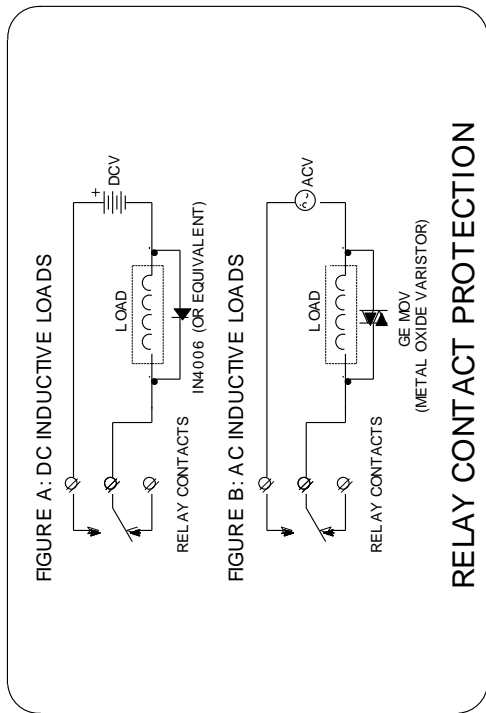
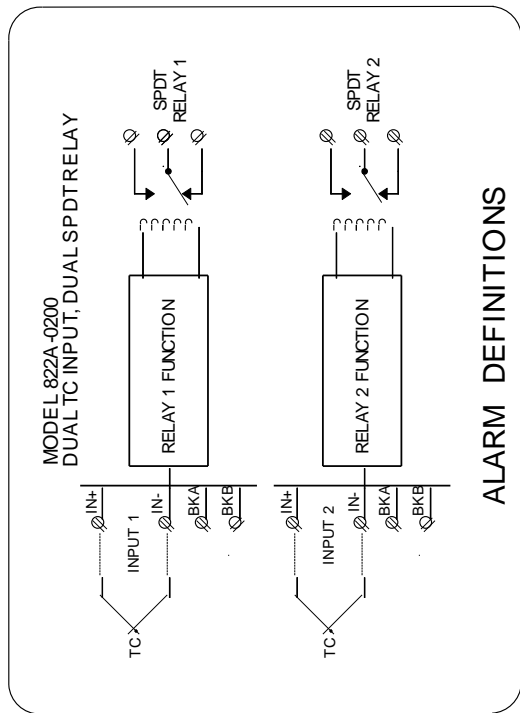

MODEL 822A
SIMPLIFIED SCHEMATIC AND
RELAY CONTACT PROTECTION

4501-626B

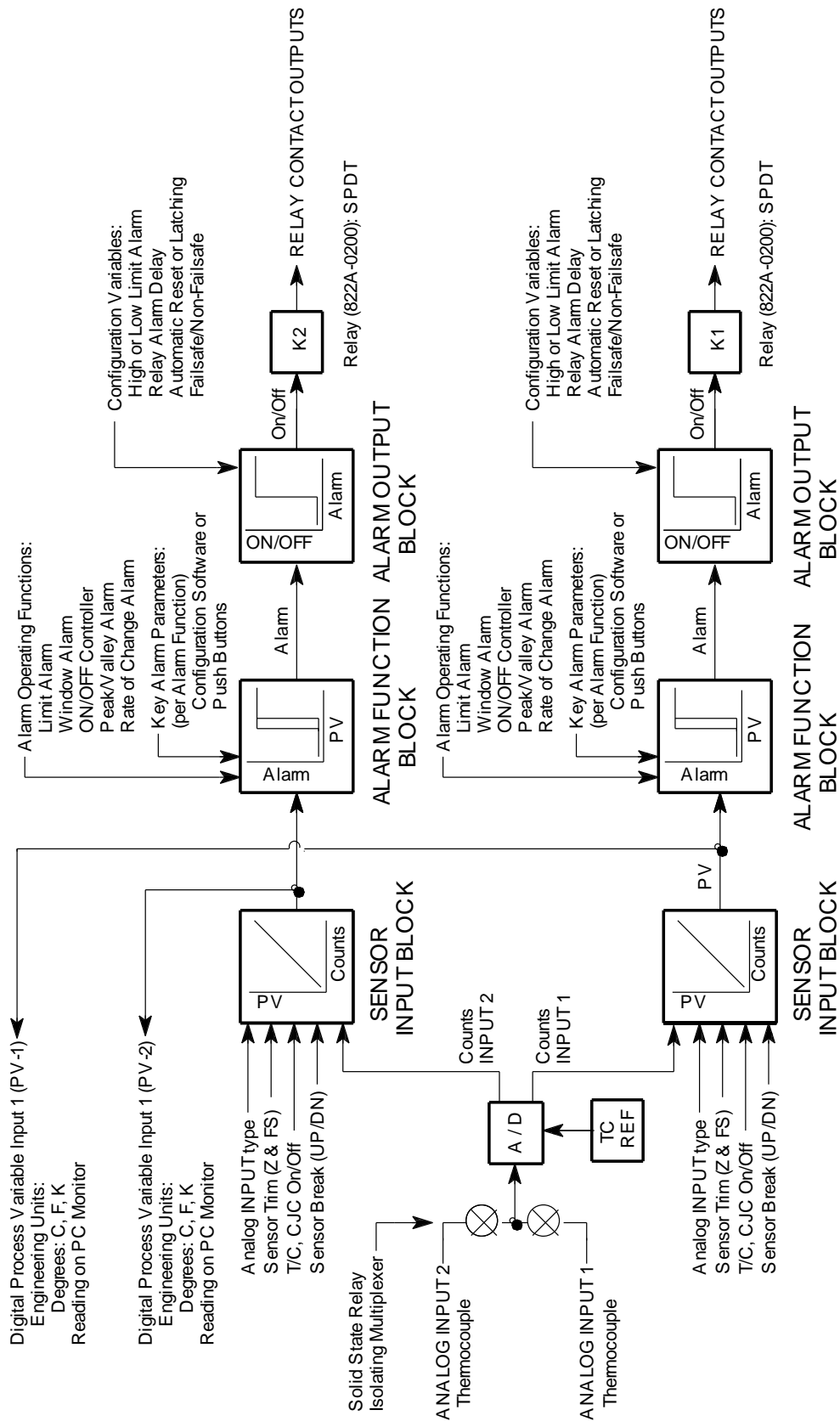

4501-693A

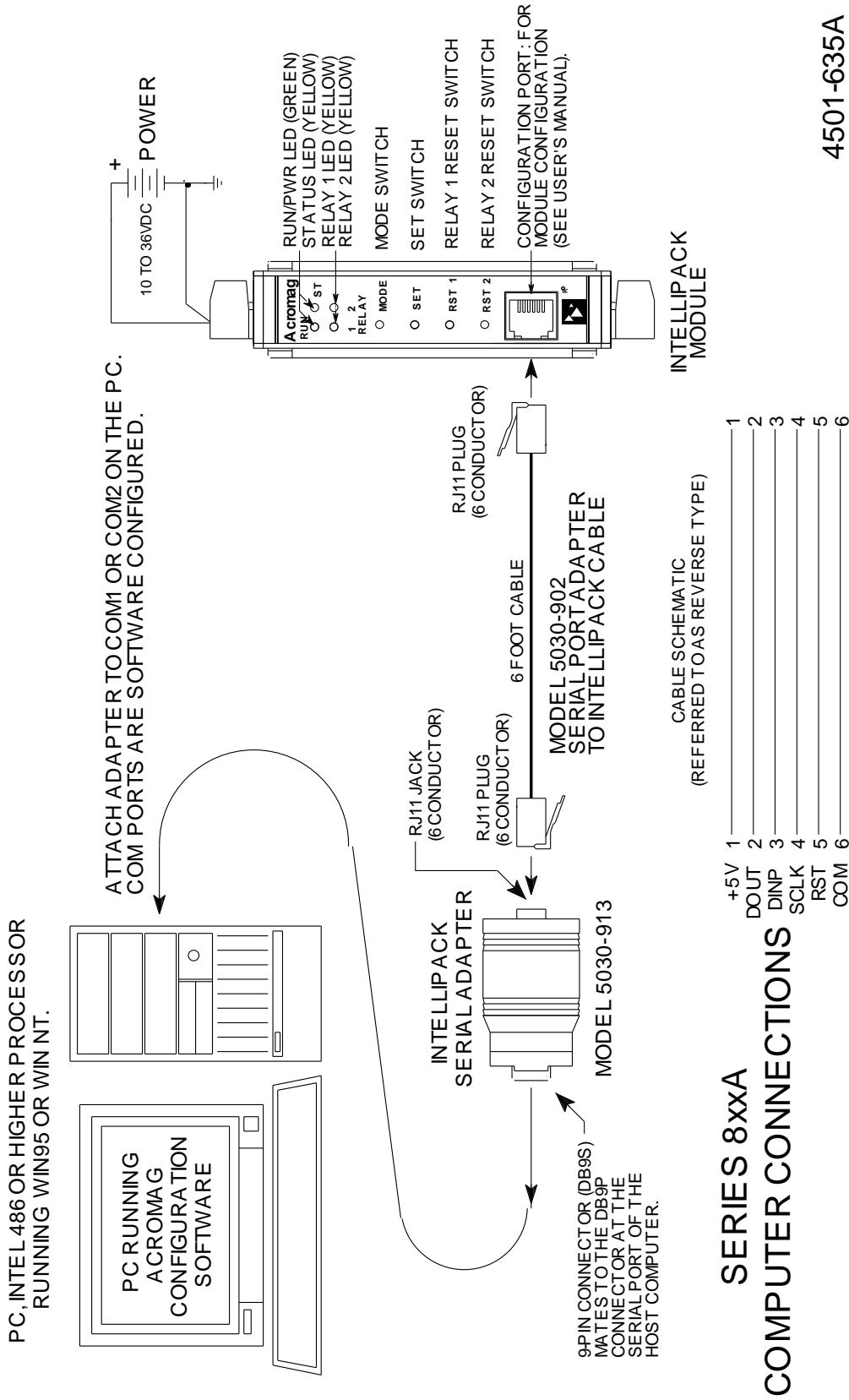

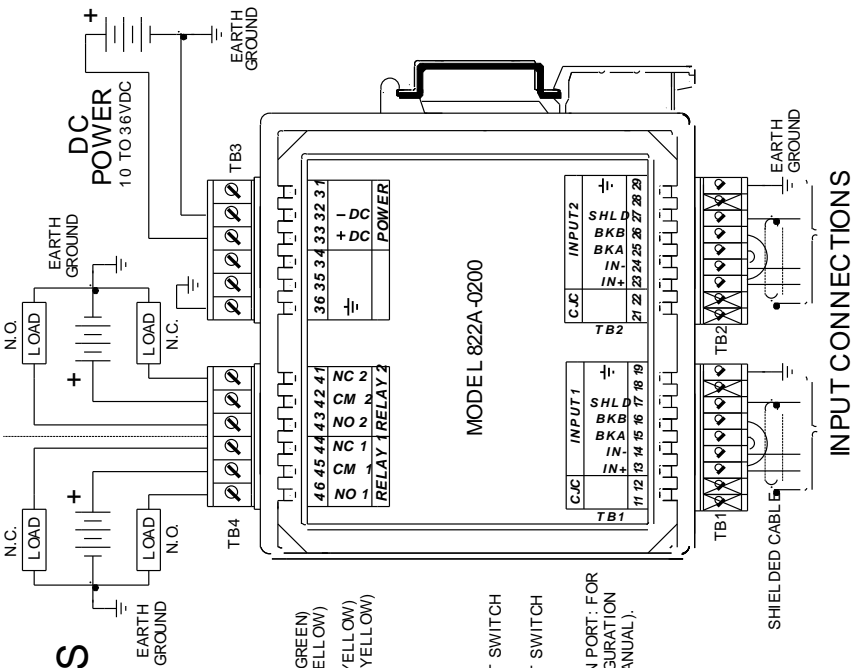

MODEL 822A-0200 ELECTRICAL CONNECTIONS

RELAY CONTACTS

CONTACTS ARE SHOWN IN DE-ENERGIZED CONDITION

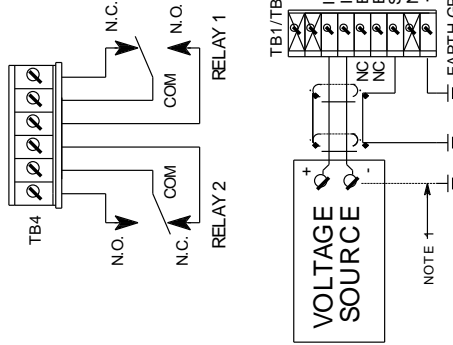

MODEL 822A INPUT 1 AND INPUT 2 CONNECTIONS AT TB1 AND TB2 TERMINALS

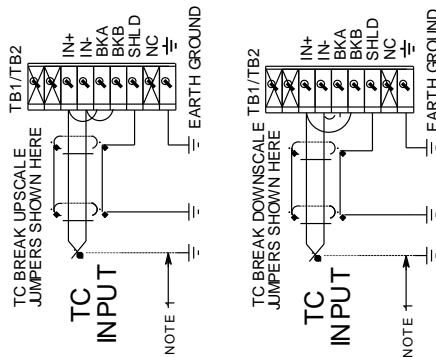

JUMPERS A AND B REQUIRED FOR TC BREAK DETECTION.

JUMPER A: JUMPER [BKA] AND [IN+] FOR UPSCALE BREAK DETECTION. JUMPER [BKA] AND [IN-] FOR DOWNSCALE BREAK DETECTION.

JUMPER B: JUMPER [BKB] AND [IN+] FOR UPSCALE BREAK DETECTION. JUMPER [BKB] AND [IN-] FOR DOWNSCALE BREAK DETECTION.

REMOVE JUMPERS FOR NO BREAK DETECTION OR FOR VOLTAGE INPUTS. BE SURE TO REMOVE OR CONFIGURE THE UPSCALE OR DOWNSCALE BREAK DETECTION JUMPERS AS REQUIRED BY YOUR APPLICATION BEFORE ATTEMPTING INPUT CALIBRATION.

NOTE 1: THIS GROUND CONNECTION IS RECOMMENDED FOR BEST RESULTS. FOR DUAL INPUTS, BOTH INPUTS SHOULD BE GROUNDED. CHANNEL-TO-CHANNEL ISOLATION ON THIS MODEL IS LIMITED TO COMMON MODE VOLTAGES LESS THAN 48V. IF SENSORS ARE INHERENTLY CONNECTED TO GROUND, USE CAUTION AND AVOID MAKING ADDITIONAL GROUND CONNECTIONS WHICH COULD GENERATE GROUND LOOPS AND MEASUREMENT ERROR.

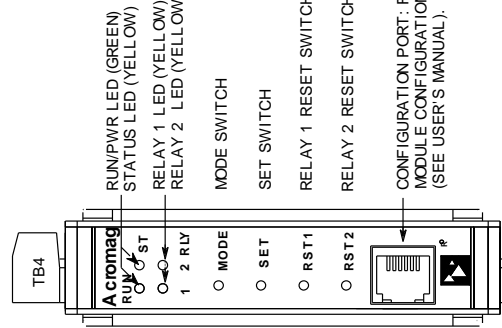

REMOVABLE (PLUG-IN TYPE) TERMINAL BLOCKS

INPUT CONNECTIONS

(SEE INPUT CONNECTIONS AT LEFT)
NOTE: TB1-1,1,12 & TB2-21,22 ARE NOT REMOVABLE AND RESERVED FOR THE C.C. TEMPERATURE SENSORS. DO NOT ATTEMPT TO CONNECT TO THESE TERMINALS.

WARNING:
FOR COMPLIANCE TO APPLICABLE SAFETY AND PERFORMANCE STANDARDS, THE USE OF SHIELDED CABLE IS RECOMMENDED AS SHOWN. ADDITIONALLY, THE APPLICATION OF EARTH GROUND MUST BE IN PLACE AS SHOWN IN THIS DRAWING. FAILURE TO ADHERE TO SOUND WIRING AND GROUNDING PRACTICES MAY COMPROMISE SAFETY AND PERFORMANCE.

SAFETY GUIDELINES MAY REQUIRE THAT THIS DEVICE BE HOUSED IN AN APPROVED METAL ENCLOSURE OR SUB-SYSTEM PARTICULARLY FOR APPLICATIONS WITH VOLTAGES GREATER THAN OR EQUAL TO 75VDC/50VAC.

4501-639A

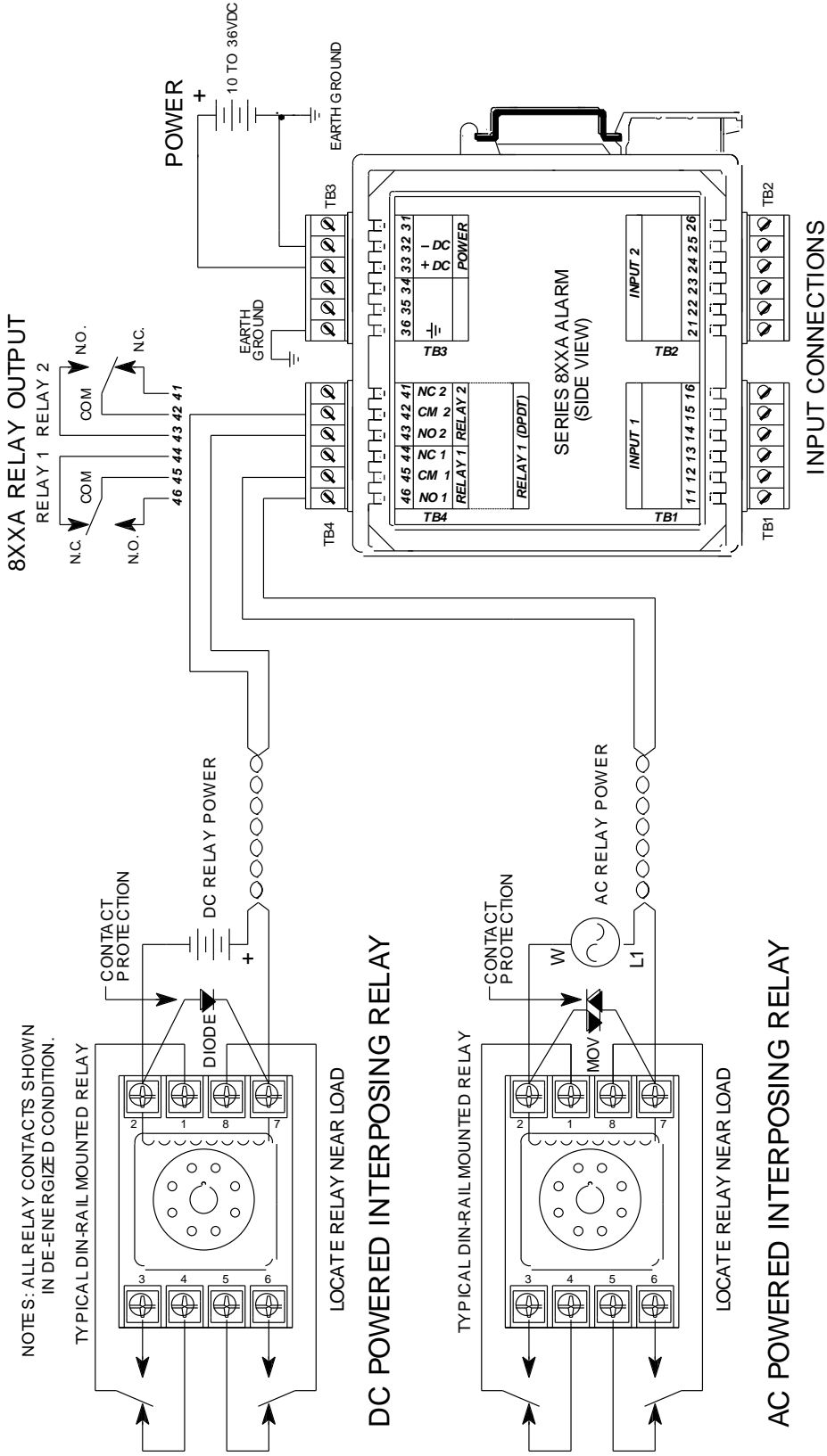

4501-634A

SERIES 8XXA INTERPOSING RELAY CONNECTIONS

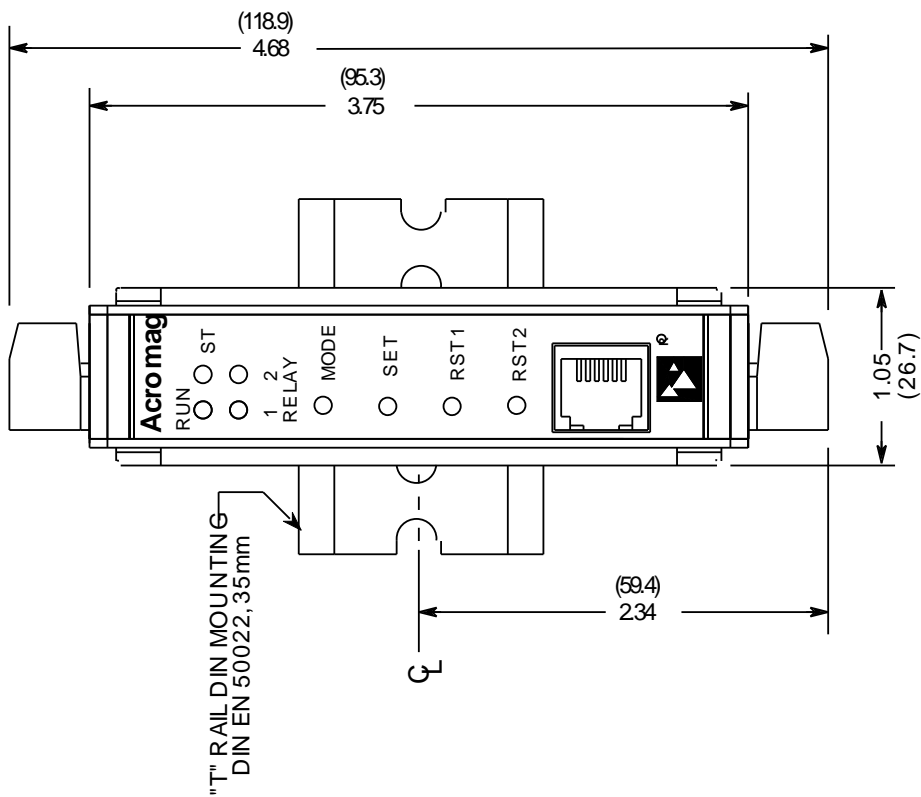
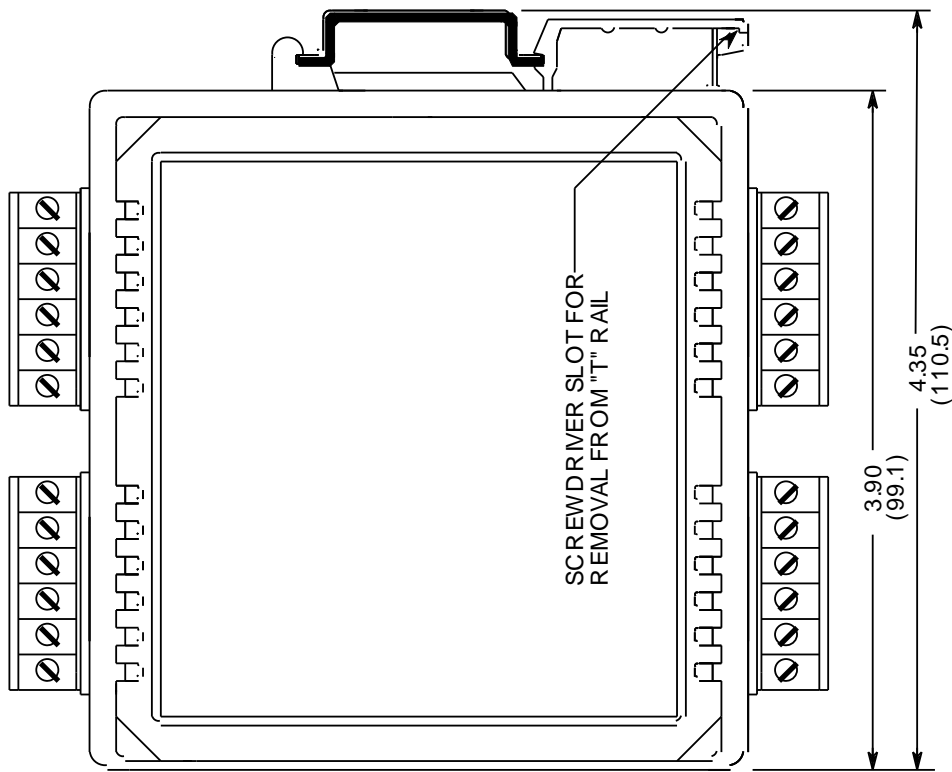

INTELLIPACK ENCLOSURE DIMENSIONS

4501-631A

Revision History

The following table details the revision history for this document:

Release Date	Version	EGR/DOC	Description of Revision
3-AUG-2017	F	CAP/JAA	Remove CE Mark due to non-RoHS compliant part. Refer to ECN# 17G016.
08 JAN 2019	G	CAP/ARP	Update Installation Category per uL.

Notes:

Notes: